

VELTRON DPT-*plus*

Microprocessor Based Ultra-Low Range
Pressure & Flow "Smart" Transmitter

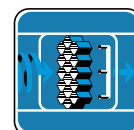

AIR MONITOR
CORPORATION

VELTRON DPT-*plus*

with Automatic Zeroing Circuit

The VELTRON DPT-*plus* transmitter is furnished with an automatic zeroing circuit capable of electronically adjusting the transmitter zero at predetermined time intervals while simultaneously holding the transmitter output signal.

The automatic zeroing circuit eliminates all output signal drift due to thermal, electronic or mechanical effects, as well as the need for initial or periodic transmitter zeroing. For transmitters operating in a moderately steady temperature location (thus no thermally

induced span drift), this automatic zeroing function essentially produces a "self-calibrating" transmitter. The automatic zeroing circuit will re-zero the transmitter to within 0.1% of its operating span; for a transmitter with a 0.02 IN w.c. operating span, this represents a zeroing capability within 0.00002 IN w.c.

To permit manual calibration of the VELTRON DPT-*plus*, an electronic switch is provided to permit manual positioning of the zeroing valve.

Performance Specifications

Transmitter

Accuracy. 0.1% of Natural Span, including hysteresis, deadband, non-linearity, and non-repeatability.

Type. Differential pressure, flow, and mass flow.

Ranges.	Natural Spans	Bi-Polar Natural Spans
	0 to 25.00 IN w.c.	
	0 to 10.00 IN w.c.	-10.00 to 10.00 IN w.c.
	0 to 5.00 IN w.c.	- 5.00 to 5.00 IN w.c.
	0 to 2.00 IN w.c.	- 2.00 to 2.00 IN w.c.
	0 to 1.00 IN w.c.	- 1.00 to 1.00 IN w.c.
	0 to 0.50 IN w.c.	- 0.50 to 0.50 IN w.c.
	0 to 0.25 IN w.c.	- 0.25 to 0.25 IN w.c.
	0 to 0.10 IN w.c.	- 0.10 to 0.10 IN w.c.
	0 to 0.05 IN w.c.	- 0.05 to 0.05 IN w.c.

Span Rangeability. The calibrated span can be down ranged to 40% of the Natural Span.

Stability. $\pm 0.5\%$ of Natural Span for six months.

Temperature Effect. Zero. None; corrected by AUTO-zero.
Span. 0.015% of Natural Span/ $^{\circ}$ F.

Mounting Position Effect. None; corrected through transmitter automatic zeroing.

Span and Zero Adjustment. Digital, via internally located pushbuttons.

Low Pass Filtration. Response time to reach 98% of a step change is adjustable from 2.0 to 250.0 seconds.

Overpressure and Static Pressure Limit. 25 psig.

Automatic Zeroing.

Accuracy. Within 0.1% of calibrated span.

Frequency. Every 1 to 24 hours on 1 hour intervals.

Temperature Limits.

-20 to 180 $^{\circ}$ F Storage; +32 to 140 $^{\circ}$ F Operating.

Humidity Limits. 0-95% RH, non-condensing.

Indication

Display. A backlit, graphical LCD providing three lines of data display. Also used for programming.

Inputs/Outputs

Analog Inputs. Differential pressure (high and low), and 4-20mA, 2-wire, internally or externally loop powered temperature signal.

Analog Outputs. Dual 4-20mA outputs, individually configurable as internally powered/non-isolated, or externally powered/isolated.

Digital Inputs. Digital contacts for AUTO-purge external start.

Digital Outputs. Dual Form A dry contacts rated for 3 amps at 24VAC/VDC for optional HI/LO alarm; or dual Form A dry contacts for AUTO-purge activation and acknowledgment.

Temperature Compensation Selection. Pushbutton selection of linearized or non-linear temperature transmitter input for the following temperature sensing types:

Type E	-50 to 1750 $^{\circ}$ F	-50 to 950 $^{\circ}$ C
Type T	-50 to 750 $^{\circ}$ F	-50 to 400 $^{\circ}$ C
Type J	-50 to 2000 $^{\circ}$ F	-50 to 1090 $^{\circ}$ C
Type K	-50 to 2000 $^{\circ}$ F	-50 to 1090 $^{\circ}$ C
RTD	-50 to 1500 $^{\circ}$ F	-50 to 815 $^{\circ}$ C

Power

Power Supply.

Standard 24VAC (20-28VAC) or 24VDC (20-40VDC).

Optional 120VAC (100-132VAC), via external transformer.

Power Consumption.

Standard: 18VA at 24VAC; 13VA at 24VDC; 36VA at 120VAC.

With AUTO-purge Management: 54VA at 24VAC; 48VA at 24VDC; 108VA at 120VAC.

Circuit Protection. Power input is fused and reverse polarity protected.

Ultra-Low Differential Pressure & Flow "Smart" Transmitter

Construction Features

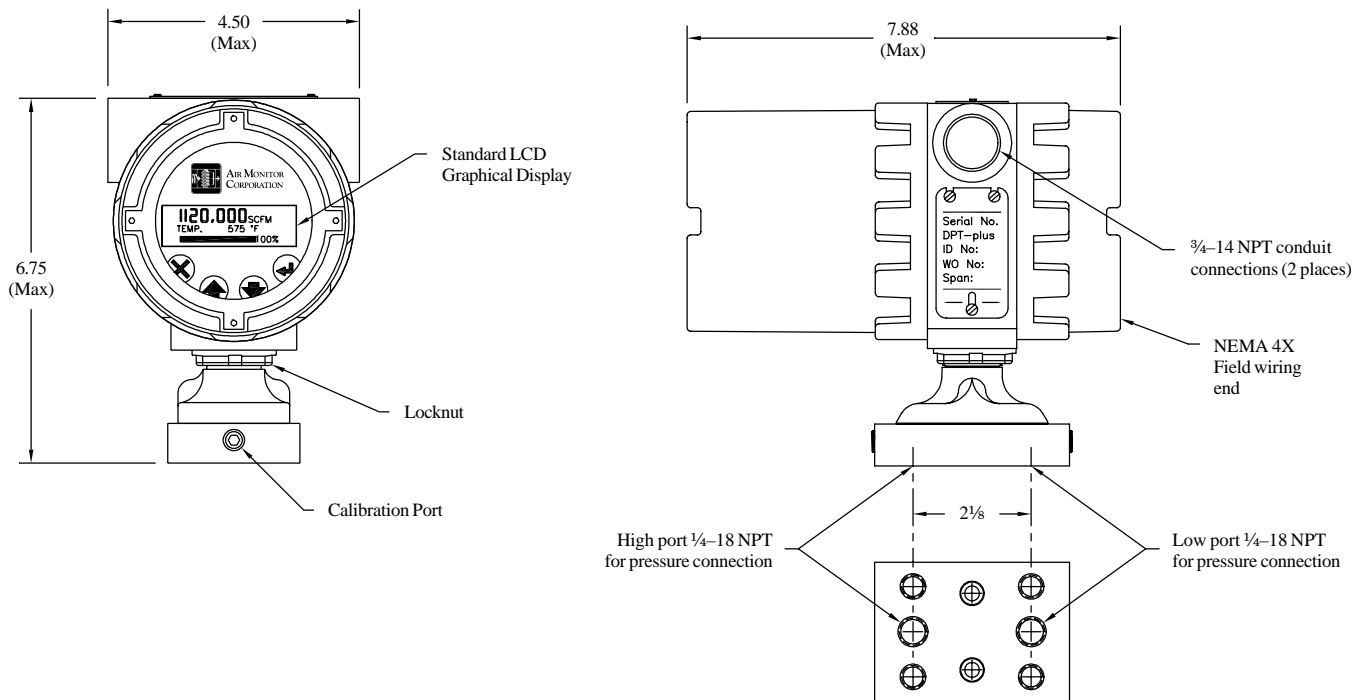

Features

Accuracy. The VELTRON DPT-*plus* is designed to maintain an accuracy of 0.1% of Natural Span. For a span of 0 to 0.05 IN w.c., this accuracy is equivalent to an output accuracy of ± 0.00005 IN w.c. differential pressure or ± 0.90 FPM velocity.

Microprocessor Based Functionality. The VELTRON DPT-*plus* on-board microprocessor performs the functions of operating parameter selection, transmitter configuration, input/output and display signal scaling, and transducer calibration. Imbedded software performs span, flow, and 3-point "K" factor calculations. Input to the microprocessor is via pushbuttons.

Electronic Respanning. The VELTRON DPT-*plus* operating span can be electronically selected anywhere between the Natural Span and 40% of Natural Span, without having to perform recalibration involving an external pressure source.

Air Density Correction. The VELTRON DPT-*plus* is capable of accepting a process temperature input to perform density correction to volumetric or mass flow. Temperature input is a 4-20mA signal from a remote temperature transmitter; non-linear temperature inputs can be linearized by the microprocessor. Temperature sensor type is software selectable from the following choices: Thermocouple types E, T, J, and K; or Platinum RTD.

High Turndown Ratio Operation. The VELTRON DPT-*plus*, with its high level of accuracy and automatic zeroing circuitry, can maintain linear output signals on applications requiring velocity turndown of 10 to 1 (equal to a velocity pressure turndown of 100 to 1).

Continuous Display of Process. The VELTRON DPT-*plus* comes equipped with a multi-line, backlit, graphical LCD for use during transmitter configuration and calibration, and to display multiple measured processes in engineering units. The LCD provides one line having 8 digits with double wide and double high characters, two 20 digit lines having standard size characters, and various descriptors for transmitter operating status.

Primary Signal Noise Filter. To eliminate background noise and pulsations from the flow signal, the VELTRON DPT-*plus* has a user selectable low pass digital filter.

AUTO-purge Management (optional). For "dirty air" applications requiring the use of an Air Monitor AUTO-purge system, the VELTRON DPT-*plus* provides the capabilities of establishing purge frequency and duration while giving the user a choice of either internally timed cycle frequency or externally triggered purge initiation. During the purge cycle all transmitter outputs are maintained at their last value prior to the start of the purge cycle.

Hazardous Locations. The VELTRON DPT-*plus* is Factory Mutual and CSA approved for the following:

- Explosion Proof: Class I, Division 1, Groups B, C, D.
- Dust Ignition Proof: Class II, III, Division 1, Groups E, F, G.
- Suitable for indoor and outdoor NEMA Type 4X hazardous locations.

Enclosure. The VELTRON DPT-*plus* is packaged in a NEMA 4X enclosure with standard industrial process connections.

VELTRON DPT-*plus*

Physical Specifications

Process Connections. Industry standard ¼"-NPT ports on 2½" centers on flanges. ½"-NPT ports on bottom of base.

Electrical Connections. Dual ¾" conduit connections. Terminal strip for field wiring and test points. External terminal strip with plug-in connectors.

O-Rings. BUNA N.

Electrical Enclosure. NEMA 4X aluminum body with Neoprene gaskets.

Paint. Polyurethane with epoxy primer.

Mounting. Flat and angle mounting brackets for 2" pipe.

Weight. 10.5 lbs.

Mounting Configurations with Optional Brackets

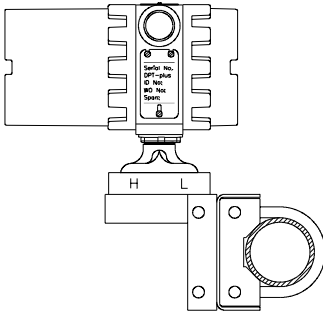

Angle Mount to Horizontal Pipe

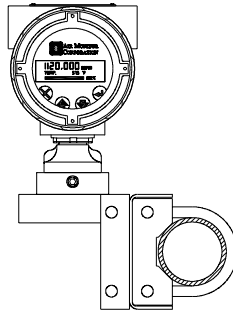

Vertical Mount to Horizontal Pipe

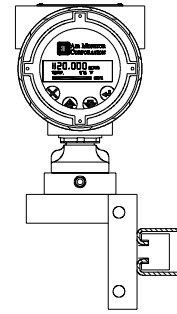

Mount to Horizontal Channel

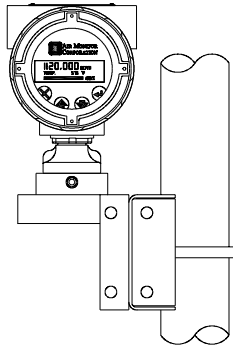

Vertical Mount to Vertical Pipe

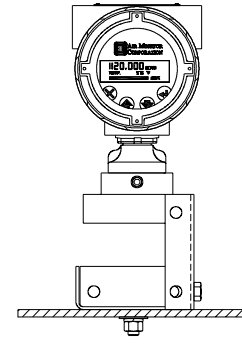

Mount to Flat Surface

Note: Mounting bracket kit includes ⅜-16 U-bolt, nuts, and washers for 2" Schedule 40 pipe, plus 4 bolts and washers to attach the transmitter to the mounting bracket.

Suggested Specification

The mass flow transmitter shall be capable of receiving flow signals (total and static pressure) from an airflow station or probe array equipped with a temperature sensing means, internally perform density correction for the process temperature, and produce individual outputs linear and scaled for standard air volume or mass flow, and temperature.

The mass flow transmitter shall contain an integral graphic LCD for use during the configuration and calibration process, and be capable of indicating multiple process parameters (temperature, flow, dp, etc.) during normal operating mode. All transmitter parameter setting, zero and span calibration, and display scaling will be performed digitally in the on-board microprocessor via input pushbuttons.

The mass flow transmitter will be available in multiple natural spans covering the range of 0.05 IN w.c. to 10.0 IN w.c. with an

accuracy of 0.1% of natural span. The transmitter shall be furnished with a transducer automatic zeroing circuit and be capable of maintaining linear output signals on applications requiring 10 to 1 velocity (100 to 1 pressure) turndown. The transmitter shall be capable of having its operating span electronically selected without having to perform recalibration involving an external pressure source.

(Optional) The transmitter will provide the means of managing a system for automatic high pressure purge of the airflow station or probe array, with user selectable purge frequency and duration, while maintaining the last transmitter output during the purge cycle.

The mass flow transmitter shall be the VELTRON DPT-*plus* as manufactured by Air Monitor Corporation, Santa Rosa, California.

