

Aluminum LO-flo

Pitot Traverse Station

Air Monitor's Aluminum LO-flo Pitot Traverse Station is a flow traverse station that combines honeycomb air straightener-equalizer with proven multi-point, self-averaging Pitot technology. The Aluminum LO-flo provides the means of measuring low air volumes of 20 to 1700 CFM in small diameter round ducts, within 2% of actual airflow.



Product Specification

- **Accuracy.** 2% of actual flow.
- **Casing.** Type 3004, .065" wall aluminum tube.
- **Flanges.** 1" wide, .08" thick aluminum sheetmetal, fusion welded to the casing.
- **Air Equalizer – Straightener.** Corrosion resistant 3003 aluminum. 3" deep x 3/8" cell.
- **Static Pressure Probe.** Copper tubing with 50/50 tin/lead solder.
- **Total Pressure Header.** Copper tubing assembled with 50/50 tin/lead solder. Stainless steel mounting bracket.
- **Connection Fittings.** 1/4" brass compression type standard. Other barb and compression fittings available.
- **Operating Temperature.** Continuous operation to 300°F.
- **Casing Depth.** 8" deep on flanged unit. 10" deep on non-flanged unit.



AIR MONITOR
CORPORATION

Aluminum LO-flo Pitot Traverse Station

Construction Features

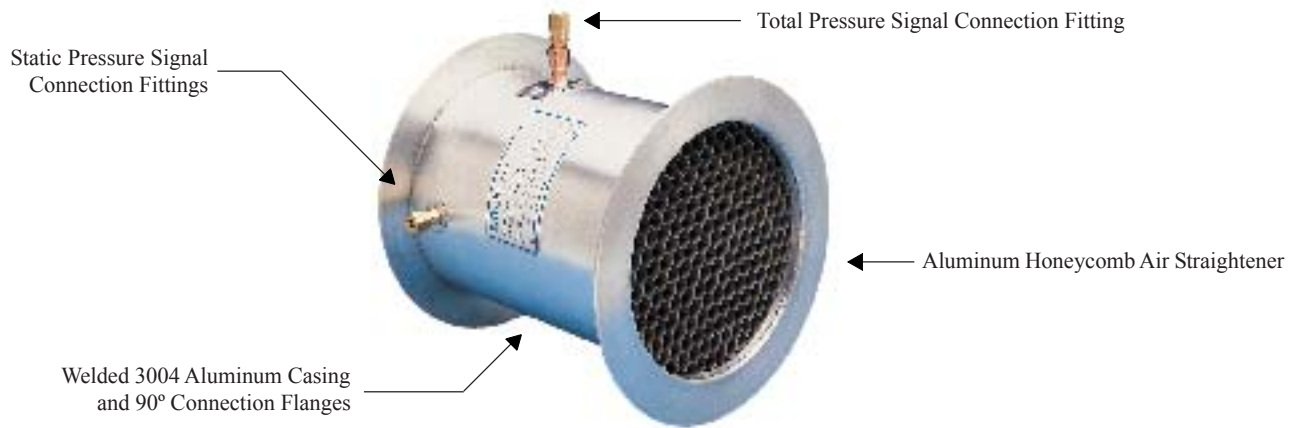

Dimensional Specification

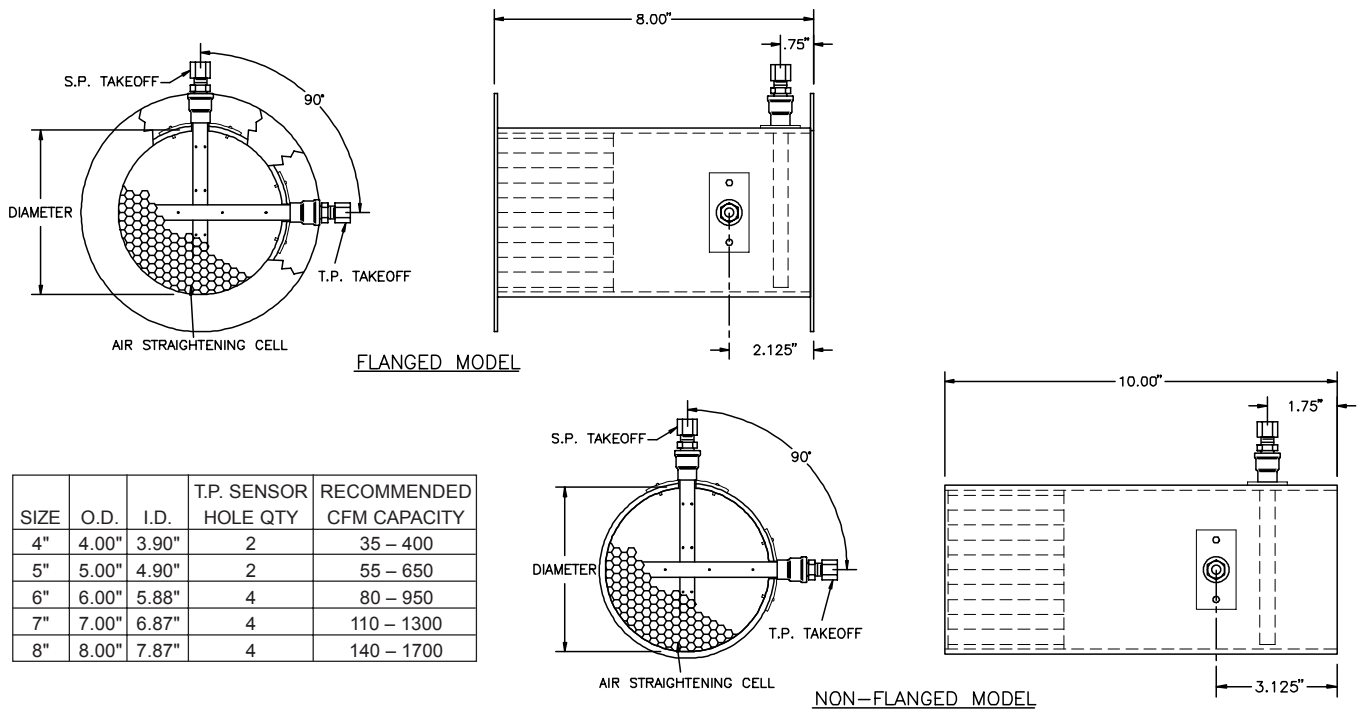

Suggested Specification

Provide where indicated, a Pitot traverse station with integral flow conditioner for continuous measurement of air volume.

Each flow traverse station shall contain a flow straightener-equalizer consisting of open cell aluminum honeycomb having a minimum cell size to length ratio of 8 to 1 to minimize the effects of turbulent and rotational flows. The Pitot total pressure sensors shall be positioned at the centers of equal concentric areas on the averaging probe; the static pressure sensor will be a bullet nose type probe.

The station's casing shall be of all welded construction using 3000 series aluminum.

The traverse station shall be capable of measuring airflow volumes within 2% of actual flow, and shall be the Aluminum LO-flo Pitot Traverse Station as manufactured by Air Monitor Corporation, Santa Rosa, California.

