

# S.O.A.P.

## Static Outside Air Probe

### Product Description

Air Monitor's S.O.A.P. static outside air probe is designed for accurate and instantaneous sensing of outside static air pressure levels.

To optimize the performance of the S.O.A.P., it must be located away from all structures and obstacles of sufficient size to create a wind induced pressure envelope. Typical locations are on an elevated position in an outdoor parking lot, in a below ground recess (landscaped or lawn area), away from buildings, in a below ground location like a parking garage with non-forced ventilation, or on a rooftop mounted pole sufficiently elevated to be outside any anticipated wind induced pressure envelope.

The circular shape of the S.O.A.P. presents a 360° radial entrance for the flow of air (wind) through the sensor. The perforations located on the

entering air edges of the parallel plates act as a means of diffusing the entering airflow to minimize the effect of non-horizontal flow on the sensor performance, thereby permitting entry flows with approach angles up to 60° from the horizontal without affecting the accuracy of the pressure measurement. The perforations located near the center of the bottom plate opposite the signal connection serve to relieve the venturi effect that will develop with higher airflow rates (winds) through parallel plates, thereby permitting non-pulsating sensing in the presence of high wind gusts. It is the combined action of the above unique design features of the S.O.A.P. static outside air probe that permits it to sense the outside atmospheric air pressure to within 1% of the actual value when being subjected to varying horizontal radial wind flows with velocities up to 40 miles per hour and sense within 2% and 3% when subjected to similar wind flows having approach angles up to 30° and 60° to the horizontal respectively.

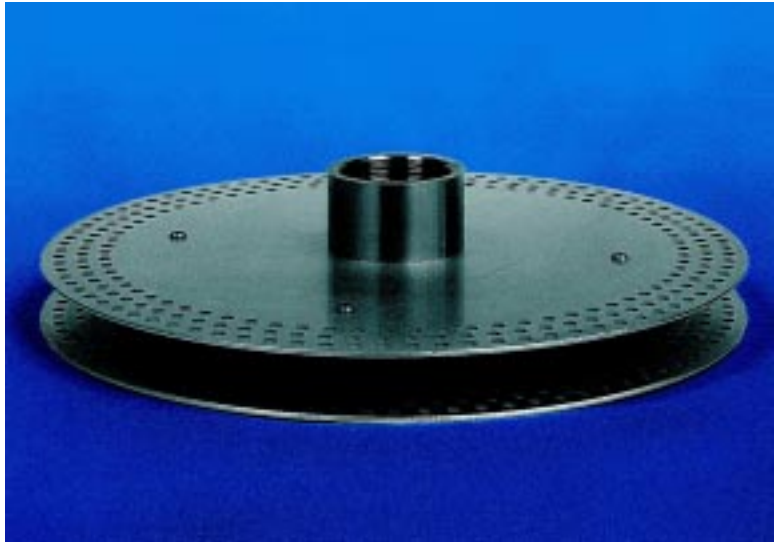

### Product Features

- Capable of sensing the outside atmospheric air pressure to within 1% of the actual value.
- Sensing accuracy not affected by wind velocities up to 40 miles per hour.
- Unique circular parallel plate design maintains sensing accuracy regardless of flow (wind) direction or pattern.
- Perforations on plate edges diffuse the effect of wind approach angles on sensor performance.
- Operation not affected nor impaired by rain or snow.
- Made entirely of Type 316 stainless steel.
- Construction has no moving parts nor required maintenance.
- Mounting via 2" FPT stainless steel connection fitting.

*Accurate airflow measurement for demanding applications*



**AIR MONITOR  
CORPORATION**

# S.O.A.P. Static Outside Air Probe

## The Need for a Stable, Common Pressure Reference

For the accurate measurement and/or control of room, laboratory, space, or building pressurization, it is essential that these sensed pressure levels be referenced to a common pressure. Ideally, that reference is the outdoors. But the usual outdoor sensor, because of its design, has to be

shielded from the wind, and often ends up located where it will be subjected to the pressure envelope developed by the wind's effect upon the building, refer to Figure 1 below. The magnitude of the pressure envelope that can be created by various wind velocities is also shown below.

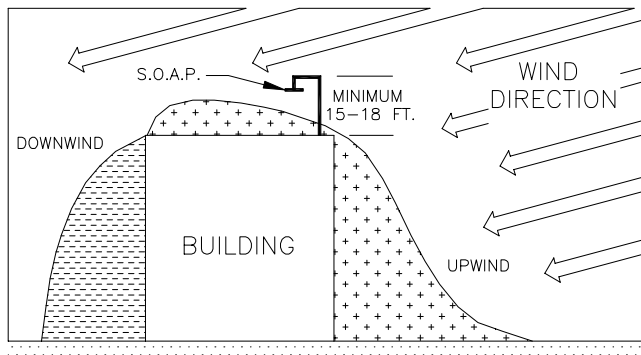
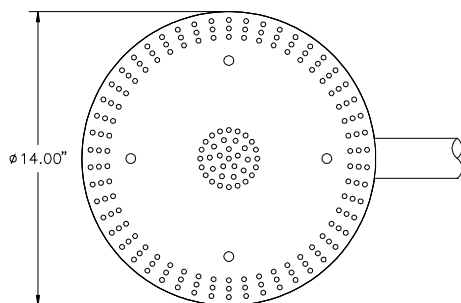

Figure 1

WIND VELOCITY MILES PER HOUR	UPWIND SIDE INCHES W.C.	DOWNWIND SIDE INCHES W.C.
10	0.035	- 0.015
15	0.088	- 0.025
20	0.14	- 0.050
25	0.22	- 0.065
30	0.30	- 0.090
35	0.42	- 0.125
40	0.54	- 0.180
45	0.70	- 0.260
50	0.85	- 0.340
55	1.06	- 0.425
60	1.28	- 0.540
65	1.70	- 0.700

## Dimensional Specification



BOTTOM VIEW

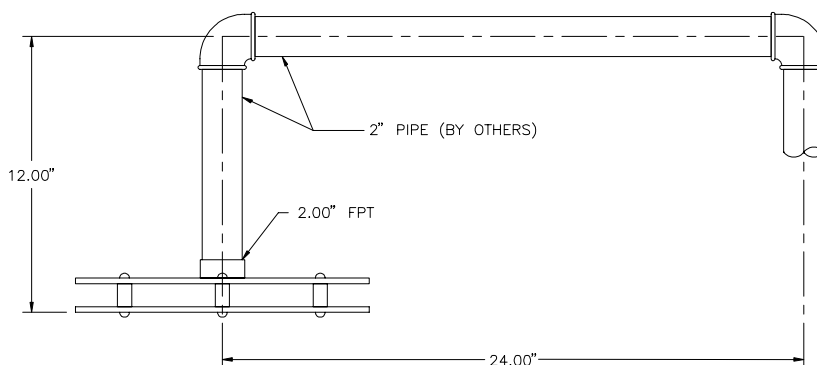

SIDE VIEW

## Suggested Specification

Provide for the room or space static pressure indicating or controlling systems an outdoor static pressure sensor constructed of 10 ga. Type 316 stainless steel with a 2" diameter FPT connection.

The outdoor air probe shall be capable of sensing the outside atmospheric air pressure to within 2% of the actual value when

subjected to radial wind velocities up to 40 miles per hour with approach angles up to 30° to the horizontal.

The static outside air probe shall be the S.O.A.P. as manufactured by Air Monitor Corporation, Santa Rosa, California.

