



# VOLU-probe

## Pitot Airflow Traverse Probes



*Accurate airflow measurement for demanding applications*

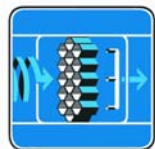

**AIR MONITOR CORPORATION**

# VOLU-probe

## Product Description

The VOLU-probe Pitot Airflow Traverse Probe is ideally suited for both new installations and retrofit applications requiring accurate airflow measurement in locations having limited straight duct runs. Multiple sets of total and static pressure sensing ports, positioned along the entire length of the VOLU-probe on an equal area basis, traverse the airstream and average the sensed pressures in separate internal manifolds. An array of VOLU-probes are used to properly

sense the typically stratified flow to provide an equal area traverse of an entire duct cross-section. The VOLU-probe is suited for installations in ductwork, fan inlets, sound attenuators, etc., operating at temperatures up to 200°F. As a primary flow sensing means, the VOLU-probe can be used in applications ranging from commercial building HVAC to laboratory, pharmaceutical and electronics production, and health care institutions.

## 2% Certified Measurement Accuracy



*Air Monitor Corporation certifies that the VOLU-probe Airflow Traverse Probe shown herein is licensed to bear the AMCA Certified Ratings Seal – Airflow Measurement Station Performance. The ratings shown are based on tests and procedures performed in accordance with AMCA Publication 611 and comply with the requirements of the AMCA Certified Ratings Program.*

### Test Data

Model. VOLU-probe  
Type. Differential Pressure

Conversion Formula.  $Velocity = 1096 \sqrt{\frac{AMS \text{ Velocity Pressure}}{Air \text{ Density}}}$

Sizes & Shapes Tested. 36" x 36" Rectangular; 36" dia. Circular  
Applicable Sizes Rated. Rectangular ductwork with cross-sectional areas between 4.5 and 18.0 square feet; Circular ductwork with cross-sectional areas between 3.5 and 14.1 square feet.

Test Setup. AMCA Standard 610, Figure 1

### Test Results – Rectangular Stations

Reference Volume, ACFM	Reference Velocity, AFPM	% Accuracy	Airflow Resistance IN w.c.
35,134	4,015	0.53	.082
31,391	3,488	0.45	.064
26,018	2,891	0.39	.044
19,456	2,162	0.23	.028
13,971	1,552	0.10	.013
8,832	981	-1.40	.005

### Test Results – Circular Stations

Reference Volume, ACFM	Reference Velocity, AFPM	% Accuracy	Airflow Resistance IN w.c.
29,602	4,188	1.03	.066
24,915	3,525	0.97	.047
18,728	2,649	0.30	.033
14,463	2,046	0.15	.017
10,455	1,479	0.16	.010
8,285	1,172	-1.37	.005

## How It Works

The VOLU-probe operates on the Fechheimer Pitot derivative of the multi-point, self-averaging Pitot principle to measure the total and static pressure components of airflow. Total pressure sensing ports, with chamfered entrances to eliminate air direction effects, are located on the leading surface of the VOLU-probe to sense the impact pressure ( $P_t$ ) of the approaching airstream (see Figure 2). Fechheimer pair of static pressure sensing ports, positioned at designated angles offset from the flow normal vector, minimize the error inducing effect of directionalized airflow. As the flow direction veers from the normal, one static sensor is exposed to a higher

pressure ( $P_s + \text{part of } P_t$ ), whereas the other static sensor experiences a lower pressure ( $P_s - \text{part of } P_t$ ) of the same magnitude, thereby canceling out the undesired effect of partial total pressure ( $P_t$ ). It is this unique design of offset static pressure and chamfered total pressure sensors (see Figure 1) that makes the VOLU-probe insensitive to approaching multi-directional, rotating airflow with yaw and pitch up to 30° from straight flow, thereby assuring the accurate measurement of the sensed airflow rate without the presence of an airflow straightener upstream. This unique design of the VOLU-probe is covered by U.S. Patent No. 4,559,835.

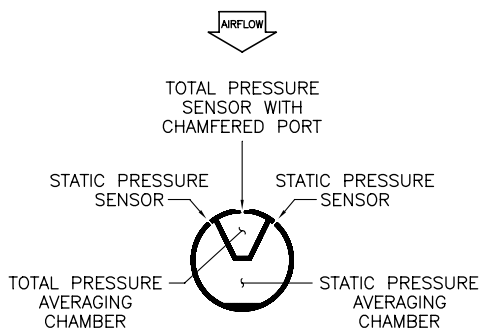

Figure 1

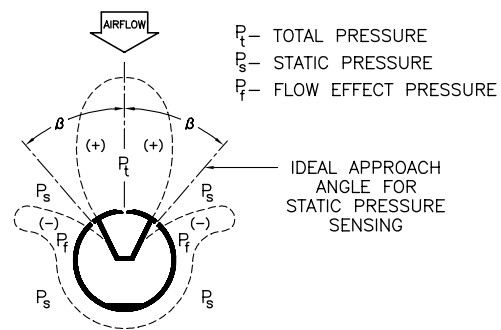

Figure 2

# VOLU-probe/1 & 2

## VOLU-probe/1 – Externally Mounted

The VOLU-probe/1 is designed for mounting in ducts by drilling two holes in opposing walls, without the need to enter those structures.

The VOLU-probe/1 is furnished with a threaded end support, gasketed washer and nut, and a mounting plate with signal take-off 1/8" FPT connections.

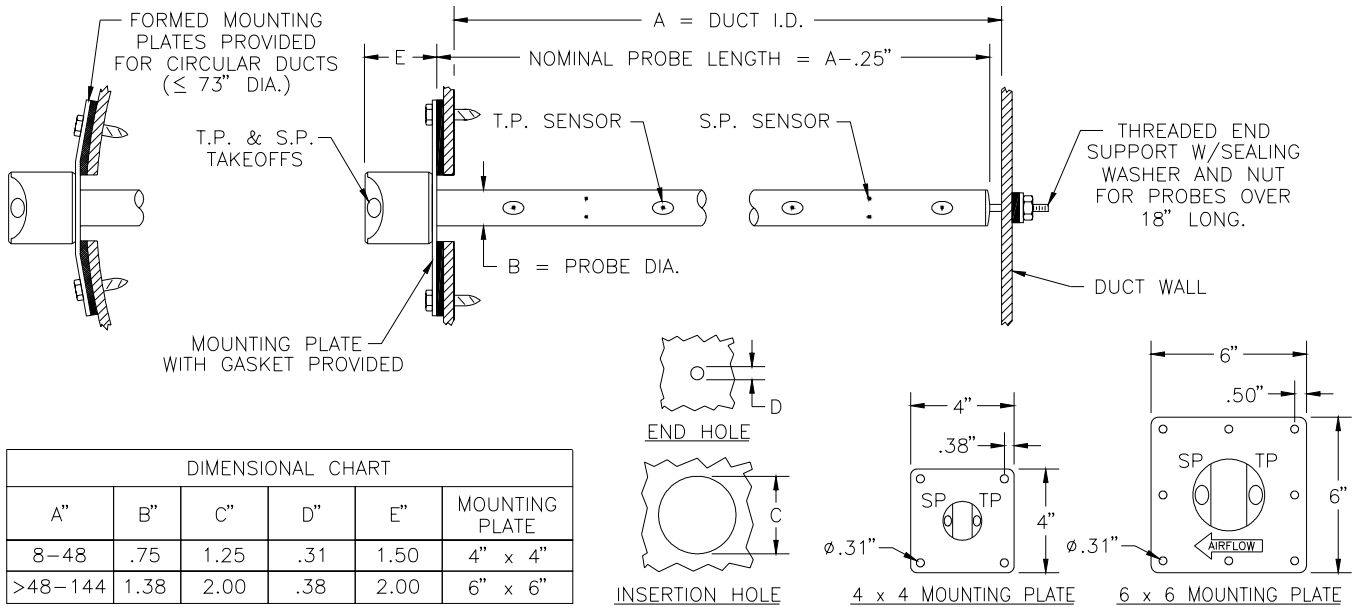

## VOLU-probe/2 – Internally Mounted

The VOLU-probe/2 is designed for larger ducts where the size permits entry for installation, or where duct external accessibility or clearance is insufficient to permit probe mounting from outside of the duct.

The VOLU-probe/2 is furnished with interior mounting end support plates, and midpoint signal take-off 1/8" FPT connections.

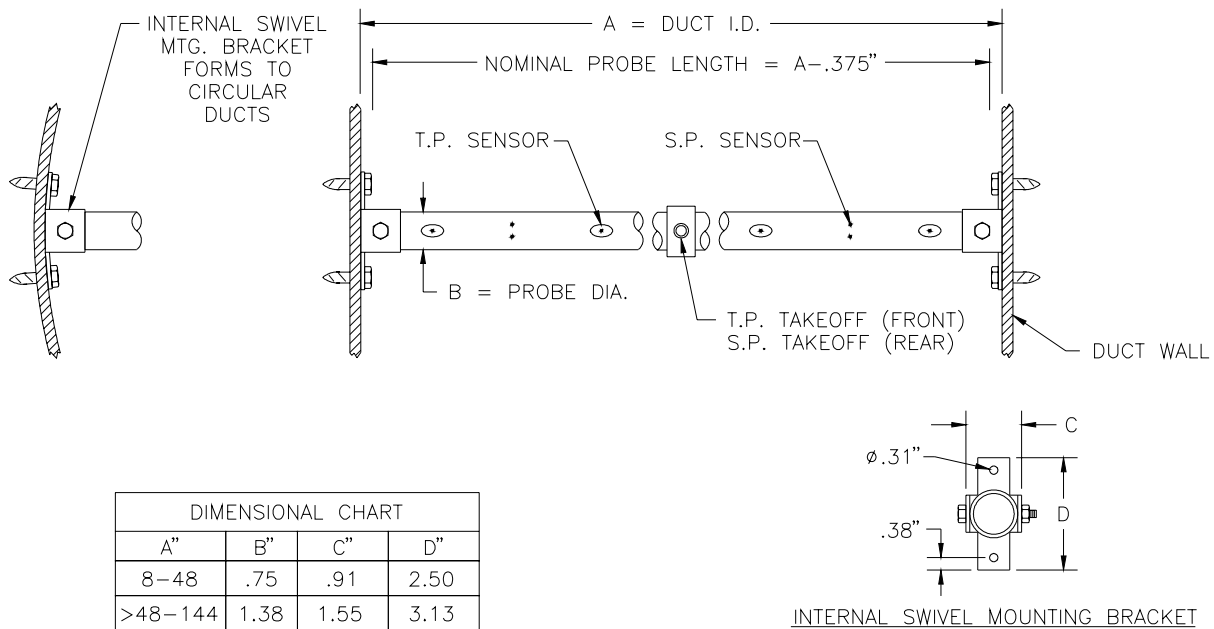

# VOLU-probe/3 & 4

## VOLU-probe/3 – Insertable/Removable

The VOLU-probe/3 is designed for mounting in ducts where periodic probe removal may be required for cleaning and/or inspection.

The VOLU-probe/3 is furnished with a bell-shaped end support for ease of reinsertion.

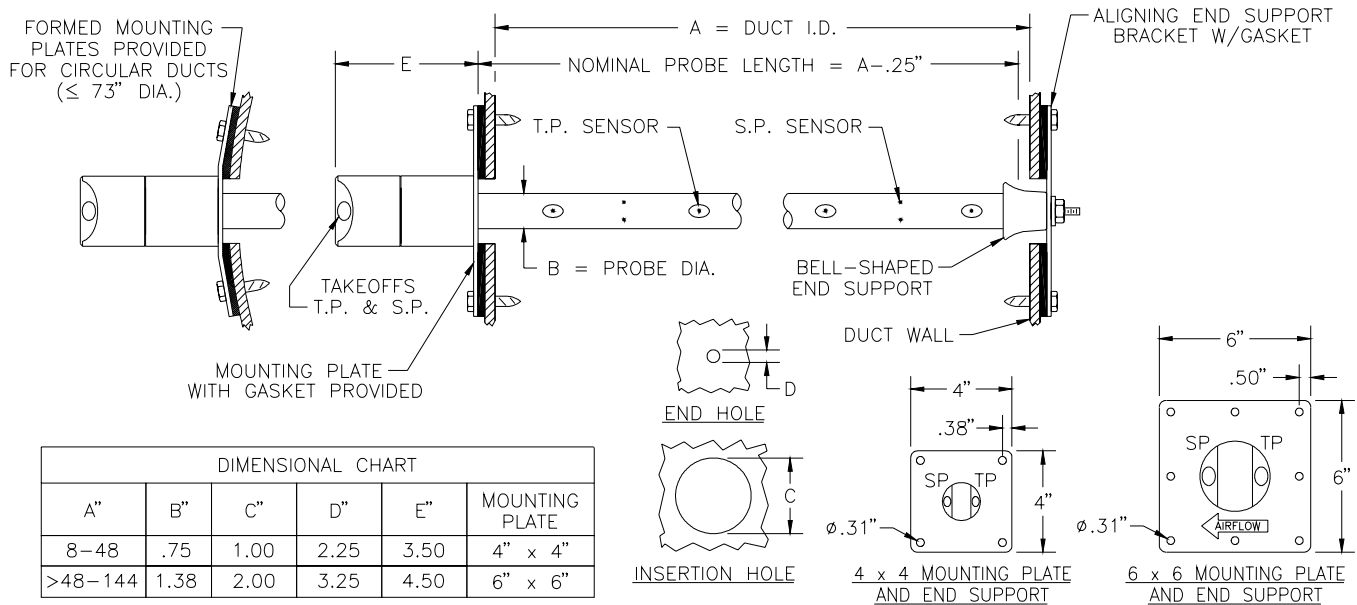

## VOLU-probe/4 – Self-Supported

The VOLU-probe/4 is designed for industrial HVAC and process air applications where the duct casing is of sufficiently heavy gauge or plate construction to support the cantilevered weight of this self-supported VOLU-probe.

The VOLU-probe/4 requires no end support and is ideal where periodic removal of the probe may be required for cleaning and/or inspection.

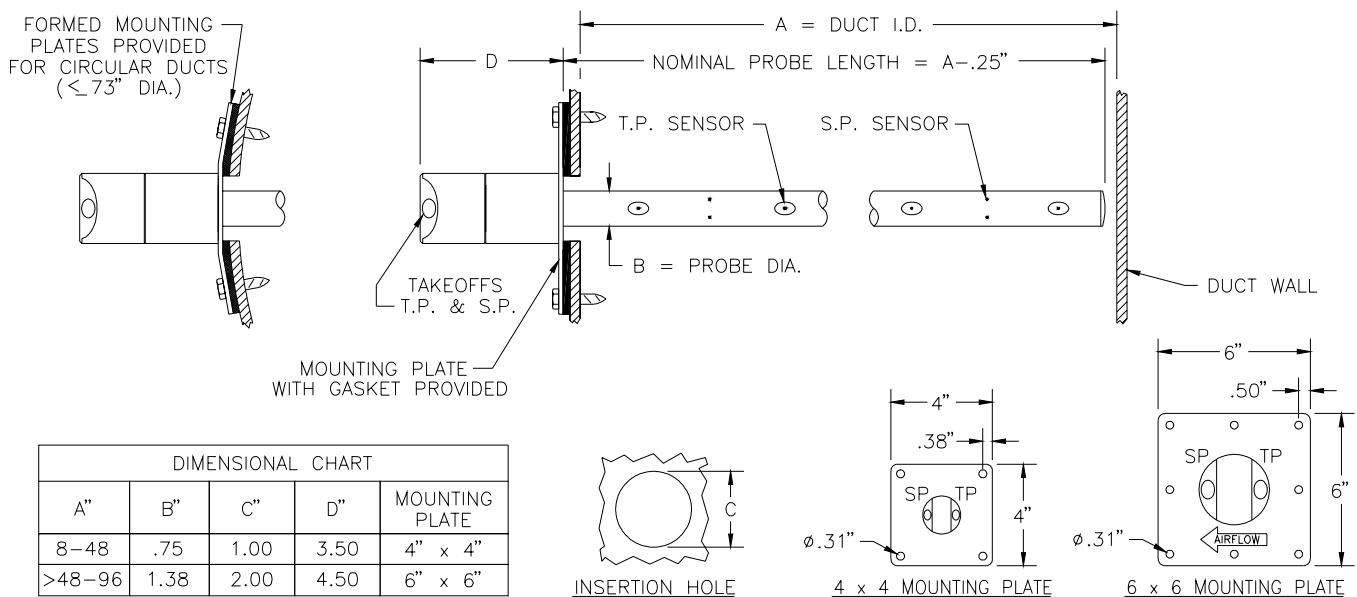

# Airflow Traverse Probes

## Construction Features

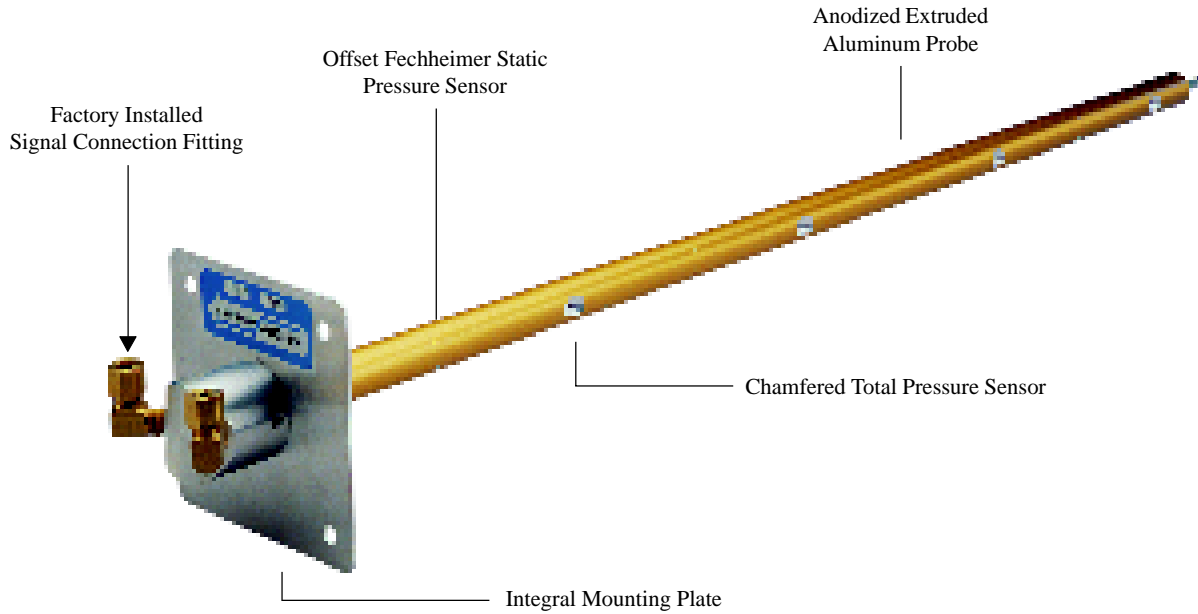

## Airflow Resistance

**Negligible Resistance to Airflow.** The VOLU-probe's cylindrical configuration and smooth surface free of external sensor protrusions permit the airstream to flow unrestricted around and between the installed traverse probe, creating a very minimal if not negligible resistance to airflow.

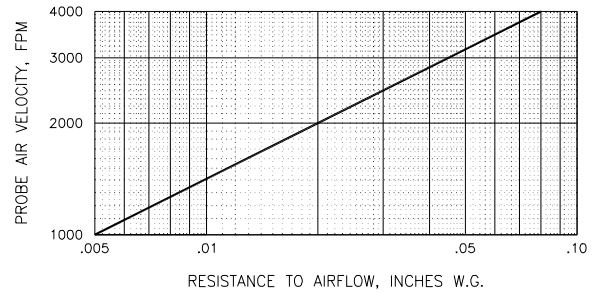

## Traverse Probe Quantities

When installed per Air Monitor's Minimum Installation Requirements (see Page 6), the quantity and placement of the VOLU-probe airflow traverse probe for a given duct size and configuration

(round or rectangular) will produce assured measuring accuracies of  $\pm 2\%$  of actual flow.

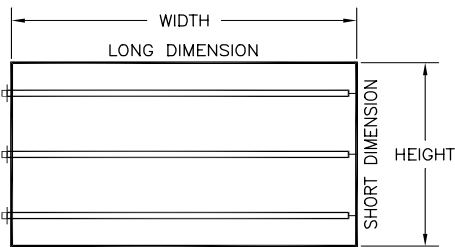

FOR SQUARE AND RECTANGULAR DUCTS

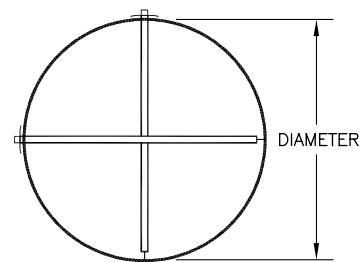

FOR CIRCULAR DUCTS

Height Dimension	Min. Qty of VOLU-probes Recommended	Height Dimension	Min. Qty of VOLU-probes Recommended
8" to 12"	1	> 54" to 84"	4
> 12" to 30"	2	> 84" to 120"	5
> 30" to 54"	3	> 120" to 180"	6

Height Dimension	Min. Qty of VOLU-probes Recommended
8" to 18"	1
> 18" to 72"	2
> 72"	3

# VOLU-probe

## Minimum Installation Requirements

**Note:** VOLU-probe locations shown are **not** ideal. The locations indicate the **minimum** clearance required from air turbulence producing sources. Wherever possible, the VOLU-probe should be installed where greater runs of straight duct (or clearances) than shown below exist.

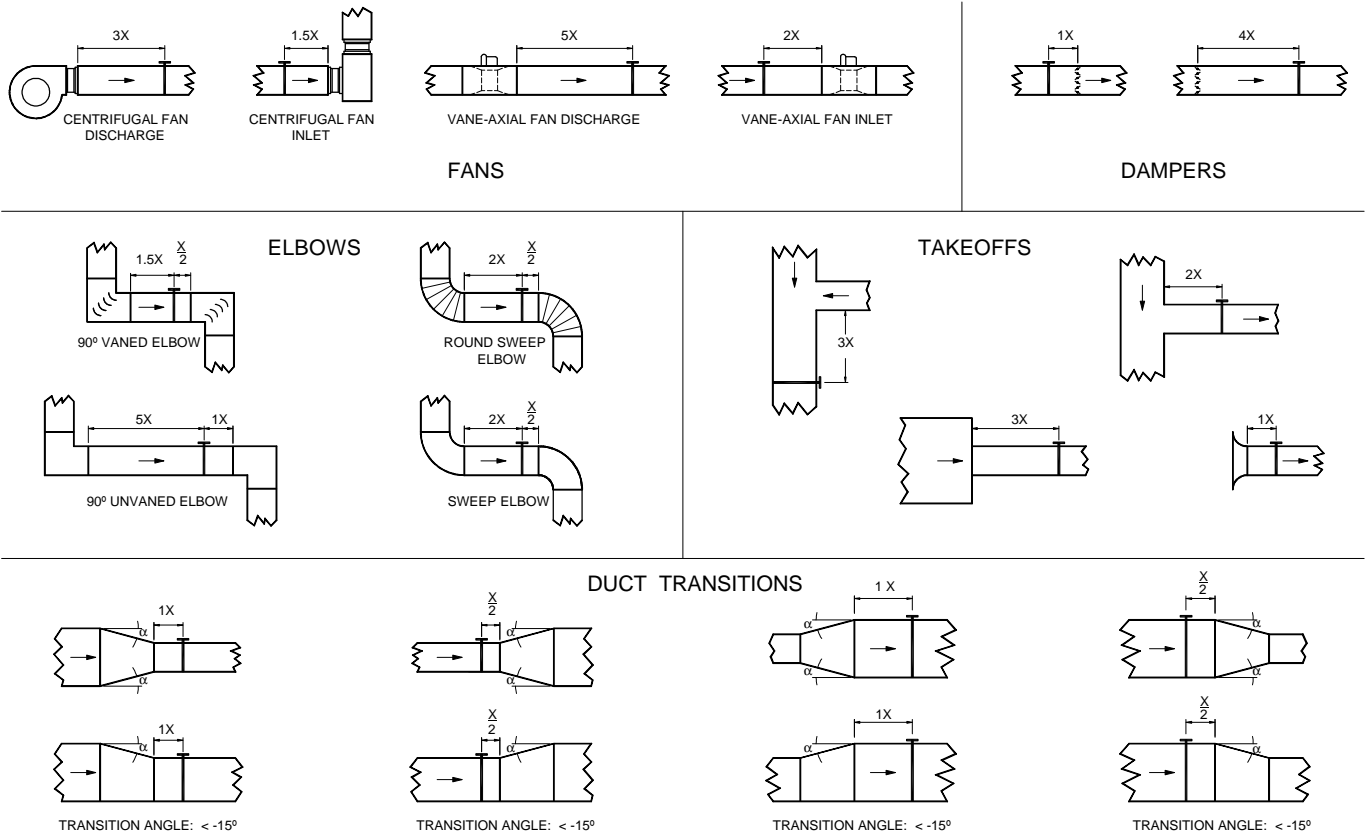

Rectangular Duct:  $x = \frac{2(H \times W)}{H + W}$

Circular Duct:  $x = \text{Duct Diameter}$

## Suggested Specification

Provide where indicated, an array of airflow traverse probes capable of continuously monitoring the fan or duct capacities (air volumes) they serve.

Each airflow traverse probe shall contain multiple total and static pressure sensors located along the exterior surface of the cylindrical probe and internally connected to their respective averaging manifolds. The flow sensors shall not protrude beyond the surface of the probe(s), and shall be the offset (Fechheimer) type for static pressure and the chamfered impact type for total pressure measurement. The airflow sensing probe's measurement accuracy shall not be affected by directional flow having pitch and/or yaw angles up to 30°. Each airflow traverse probe shall be of extruded aluminum construction and furnished with mounting plate(s), gasket, and signal fittings suitable for HVAC duct installation.

Total and static pressure sensors shall be located at the centers of equal areas (for rectangular ducts) or at equal concentric area centers (for circular ducts) along the probe length.

Probes shall be AMCA certified and be capable of measuring the airflow rates within an accuracy of ±2% without the use of correction factors. The maximum allowable unrecovered pressure drop caused by the probes shall not exceed .025" w.c. at 2000 FPM, or .085" w.c. at 4000 FPM.

The airflow traverse probe shall be the VOLU-probe[1./2./3./4] as manufactured by Air Monitor Corporation, Santa Rosa, California.

