

# ELECTRA-flo/M STATION

## CIRCULAR CONFIGURATION

### THERMAL AIR FLOW MEASURING STATION

## Plus Series

**STANDARD CONSTRUCTION**

Casing.	18 ga. galvanized sheetmetal, spot welded casing seams.
Flanges.	Up to 24" dia: 1" flange, 14 ga. galvanized sheetmetal. 25" to 44" dia: 1½" flange, 14 ga. galvanized sheetmetal. 45" plus: 3/16" x 2" carbon steel barstock flange.
Casing Depth.	8"
Probe.	Type 6063 anodized extruded aluminum. 1-1/8" diameter.
Sensor Assembly.	Injection molded polycarbonate.
Sensor Type.	Sealed thermistor.
Sensor Signal Processing.	Microprocessor in each sensor node, with 12 bit A/D conversion.
Probe Mounting.	External mounted via 4" x 4" aluminum plate, with closed cell neoprene gasket.
Probe to Probe Connection.	Integral cable with RJ-45 connector. Multiple probes connect in serial configuration.
Station to Transmitter Connection.	Single cable with RJ-45 connector. Standard length 10'. Optional lengths 50' and 100'.
Sensor Pattern.	On an equal area basis for rectangular probes. On an equal concentric area basis for circular probes.

Sensors Per Station.

Station Diameter	Sensor Density	Station Diameter	Sensor Density
10" to <12"	.80 Sq. Ft. per Sensor	48" to <60"	1.65 Sq. Ft. per Sensor
12" to <18"	.90 Sq. Ft. per Sensor	60" to <90"	2.45 Sq. Ft. per Sensor
18" to <36"	1.80 Sq. Ft. per Sensor	90" to 120"	3.25 Sq. Ft. per Sensor
36" to <48"	1.60 Sq. Ft. per Sensor		

**PERFORMANCE SPECIFICATIONS**

Individual Sensor Accuracy.	2% of reading
Station Accuracy.	2-3% of flow
Sensor Temperature Accuracy.	±0.1°F
Number of Calibration Points Per Sensor.	6
Velocity Calibration Range.	0 to 5,000 FPM
Humidity Range.	0 to 95% RH, non condensing

**DIMENSIONAL INFORMATION**

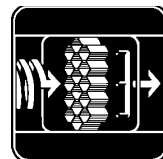
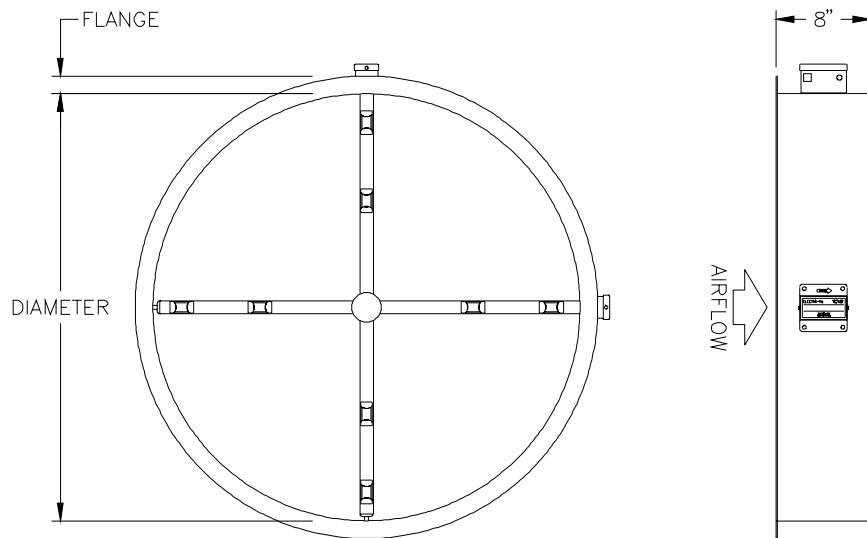

AIR MONITOR CORPORATION