

VEL-trol II

ULTRA-LOW RANGE DIFFERENTIAL PRESSURE/ FLOW TRANSMITTER / CONTROLLER

PHYSICAL SPECIFICATIONS

Signal Connections.

High and low pressure, 1/8" FPT.

Electrical Connections.

External terminal strip with plug-in connectors.
Optional terminal strip enclosure with dual 3/4" conduit connections.

Enclosure.

NEMA 1 aluminum enclosure.

Weight.

4.1 lbs.

DIMENSIONAL SPECIFICATIONS

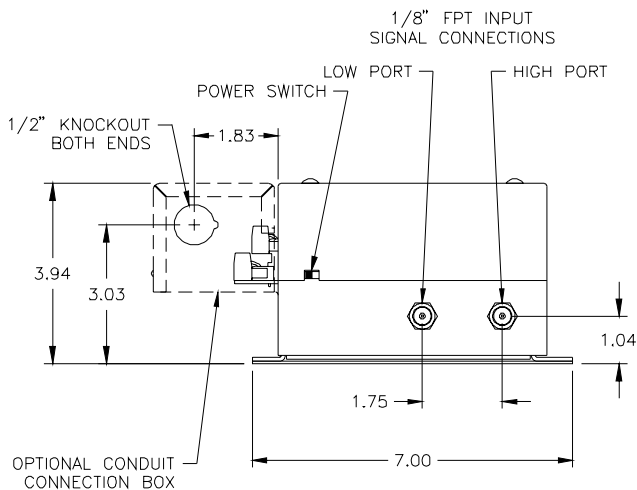
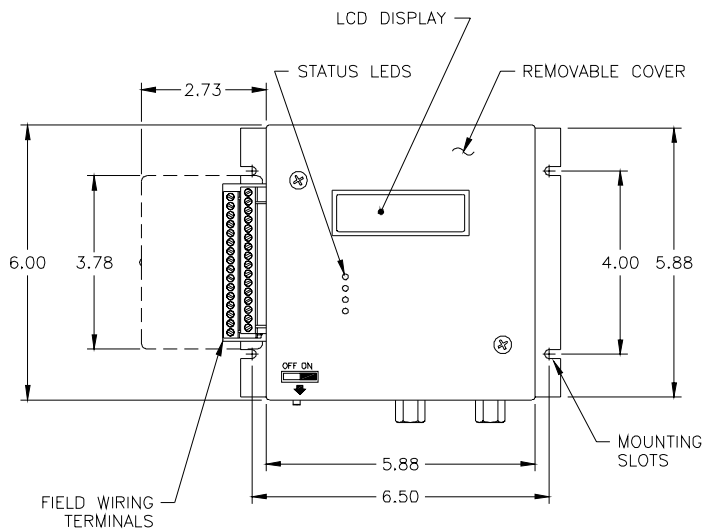

WIRING DIAGRAM

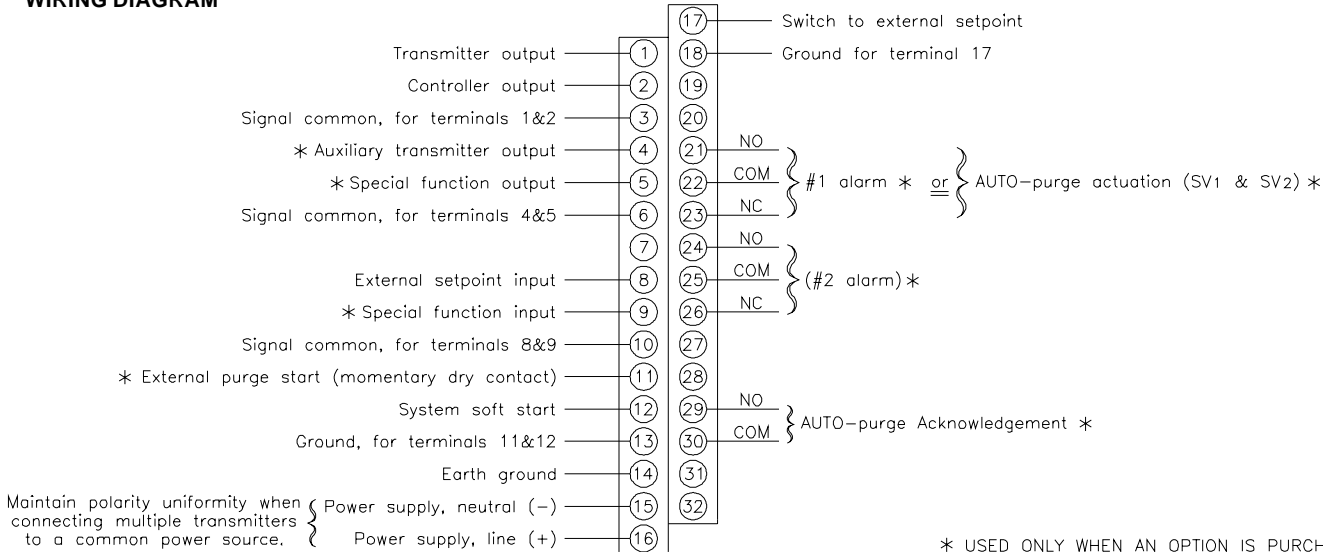

* USED ONLY WHEN AN OPTION IS PURCHASED.

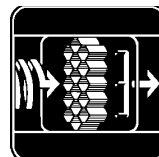

AIR MONITOR
CORPORATION