

ACCU-flow / NP

Nozzle Pitot Flow Station



Accurate airflow measurement for demanding applications



AIR MONITOR
CORPORATION

ACCU-flo / NP

Product Description

The ACCU-flo/NP is a combination precision nozzle and multi-point self-averaging Fechheimer Pitot airflow measuring station. When combined with an ultra high accuracy transmitter such as Air Monitor's VELTRON II, MASS-tron II or VELTRON DPT-*plus*, the ACCU-flo/NP provides high accuracy ($\pm 0.5\%$) flow measurement for process monitoring and control applications. Due to the combined effect of the integral flow straightener cell

and the nozzle, the ACCU-flo/NP requires little or no upstream straight run to achieve its published measurement accuracy. Constructed of either Type 316 stainless steel or carbon steel with a combination of welded and bolted flanges, the ACCU-flo/NP is capable of operation up to 900°F and is suitable for application to corrosive gases within the limitations of Type 316 stainless steel.

How It Works

Precision Nozzle. The precision nozzle incorporated in the ACCU-flo/NP reduces the measurement area by 50%, which has the effect of conditioning the velocity profile of the measured flow stream, producing highly uniform and stable process pressure signals that are measured at each total and static pressure sensing port. The nozzle also boosts the measured differential pressure by a factor of 4, ensuring high accuracy flow measurement of $\pm 0.5\%$ of actual flow down to 175 FPM.

Airflow Processing. In order to achieve its precise measurement accuracy under adverse conditions caused by turbulent, rotating, and multi-directional airflows, the ACCU-flo/NP uses a parallel cell honeycomb panel to process the flow into velocity vectors parallel with its longitudinal axis. Downstream of the cell the precision nozzle compresses the straightened airflow, which has the effect of flattening the velocity profile where it comes in contact with the total and static pressure sensing manifolds. The combination of the honeycomb panel and precision nozzle eliminates the traditional

need for long upstream straight runs of duct required to obtain accurate flow measurement. See Figure 1.

Equal Weighted Average. Within the separate total and static pressure manifolds the individually sensed pressures are pneumatically averaged in a manner that gives equal weight to each value. The equal weighted averaging compensates for any remaining minor variances in total pressure at the plane of measurement.

Fechheimer Static Pressure Measurement. Even small amounts of flow angularity can contribute to measurement error. The ACCU-flo/NP utilizes paired Fechheimer static pressure ports positioned at designated angles offset from the flow normal vector. As flow angularity veers from normal, one port is exposed to a higher pressure ($P_s + \text{part of } P_t$), whereas the other port experiences a lower pressure ($P_s - \text{part of } P_t$) of the same magnitude, thereby canceling out the undesired effect of the partial total pressure (P_t). See Figure 2.

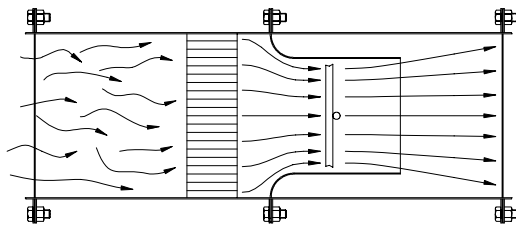

Figure 1

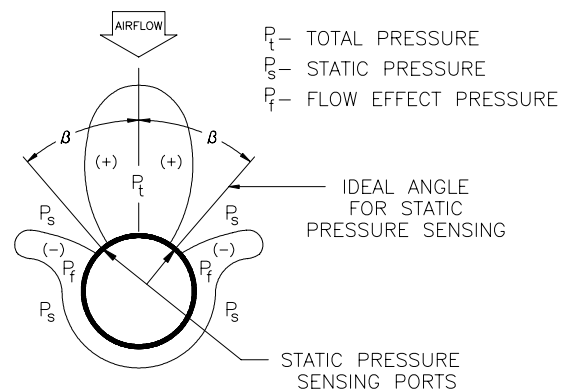

Figure 2

Specifications

Accuracy. 0.5% of actual flow.

Operating Temperature. Continuous operation to 900°F.

Maximum Static Pressure. Dependent on materials of construction, operating temperature, and installation. Contact Factory.

Casing. Model S. Rolled sheet metal, Type 316 stainless steel.
Model HP. Pipe, Type 316 stainless or carbon steel.

Flanges. Model S. 10 ga. plate, Type 316 stainless steel.
Model HP. 150 lb. raised face flange, stainless or carbon steel.

Nozzle. Type 316 stainless steel.

Air Straightener Cell. 1/4" or 3/8" hexagonal welded cell, Type 316 stainless steel.

Total & Static Pressure Sensors. Type 316 stainless steel.

Signal Fittings. 1/4" FPT, stainless or carbon steel to match casing material.

Non-Recovered Pressure Loss. 42-45% of the velocity head (pressure) for the design flow rate.

Special Construction. Integral temperature sensor and transmitter. Static pressure port. Temperature port. 316 stainless zeroing valve with 1/4" NPTF connection.

Nozzle Pitot Flow Station

Construction Features

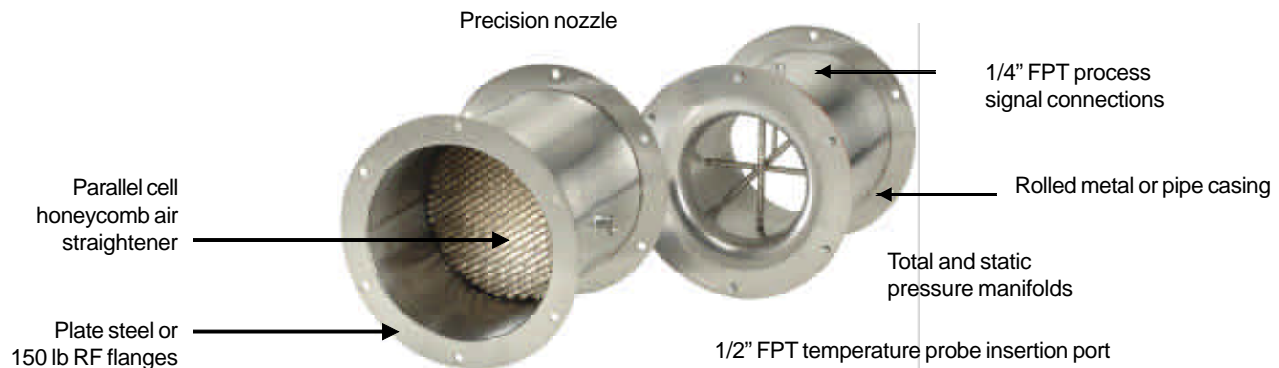

Minimum Installation Requirements

These installation locations indicate the **minimum** clearance from a source of airflow disturbance. If more than the minimum is available, proportionally adjust the upstream and downstream clearances. Avoid locating the ACCU-flo/NP where it will be subjected to condensation from a coil or humidifier. Contact Air Monitor's Applications Engineering Department to discuss sub-minimum installation.

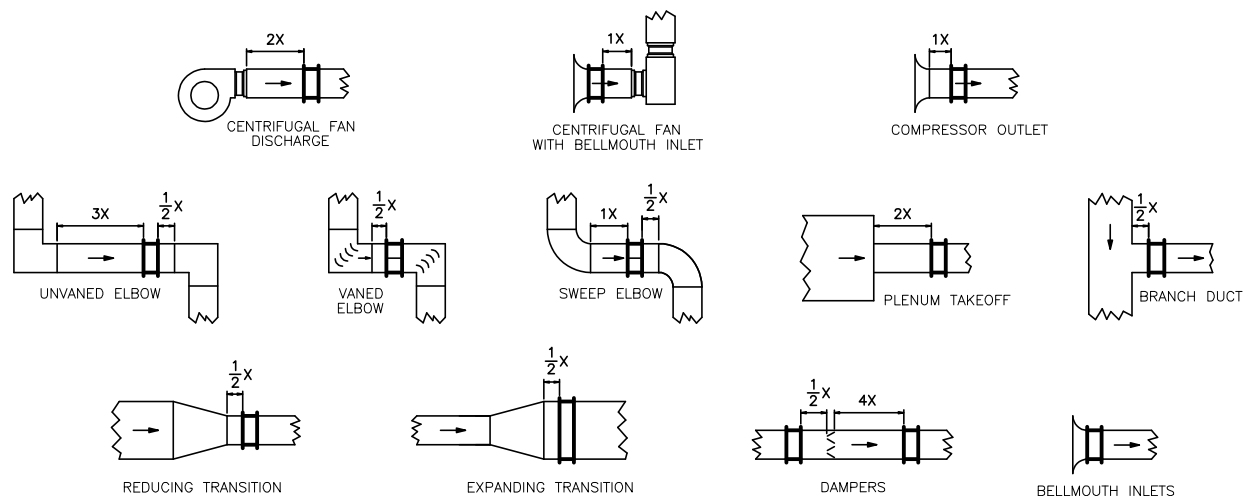

Suggested Specification

Provide at each indicated location a precision nozzle, multi-point self-averaging Pitot airflow measuring station integral flow straightener, for continuous flow rate measurement.

Each flow measurement station shall contain Fechheimer Pitot traverse probes with multiple total and static pressure sensors placed in the minimum throat diameter of a precision flow nozzle. Flow straightener in the form of an open cell honeycomb structure having a minimum cell length-to-size ratio of 8:1 shall be mounted upstream of the nozzle and traverse probes to eliminate turbulent, rotational and angular flow.

The flow nozzle shall reduce the area at the point of measurement by 50% and shall produce a uniform velocity profile.

The entire flow station shall be constructed of Type 316 stainless steel [or carbon steel] casing and flange materials that the construction of the pipe or duct into which the station will be mounted.

The flow traverse station shall be capable of measuring the volumetric flow within an accuracy of 0.5% of reading over a range of 175 to 10,000 FPM and shall require no length of straight duct upstream of the measurement point.

The station shall be the ACCU-flo/NP Nozzle-Pitot Flow Station as manufactured by Air Monitor Corporation, Santa Rosa, California.

ACCU-flo / NP – Nozzle Pitot Flow Station

Dimensional Specifications – Model S

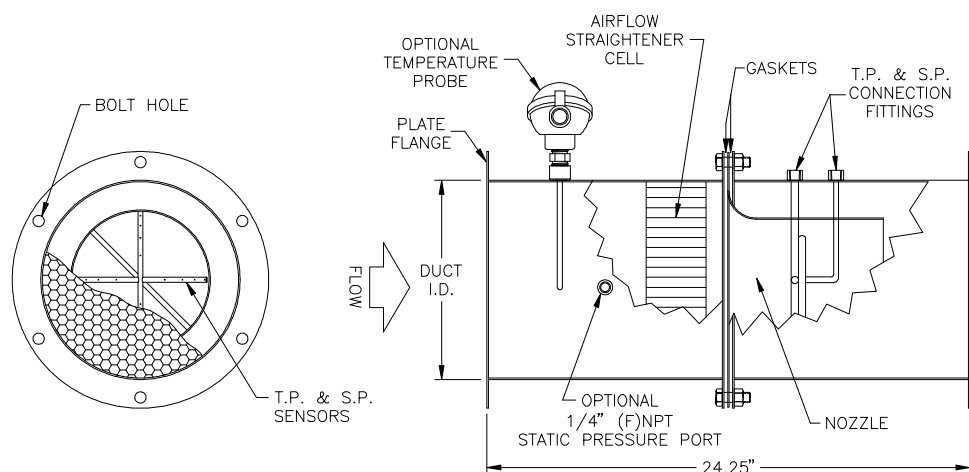

Nominal Duct Size	Duct ID	Duct Wall	Flange O.D.	Bolt Circle	Bolt Qty	Cell Hex Size	Nominal Duct Size	Duct ID	Duct Wall	Flange O.D.	Bolt Circle	Bolt Qty	Cell Hex Size
4"	3.87	0.048	6.06	5.31	6	1/4 x 3	16"	15.85	0.075	19.13	18.00	8	3/8 x 3
6"	5.87	0.075	8.09	7.31	6	1/4 x 3	18"	17.85	0.075	21.13	20.00	8	3/8 x 3
8"	7.85	0.075	10.38	9.56	6	3/8 x 3	20"	19.85	0.075	23.13	21.75	12	3/8 x 3
10"	9.85	0.075	12.88	11.81	6	3/8 x 3	24"	23.85	0.075	27.13	25.88	12	3/8 x 3
12"	11.85	0.075	15.13	14.00	6	3/8 x 3	30"	29.85	0.075	34.13	32.38	16	3/8 x 3
14"	13.85	0.075	17.13	16.00	8	3/8 x 3							

Dimensional Specifications – Model HP

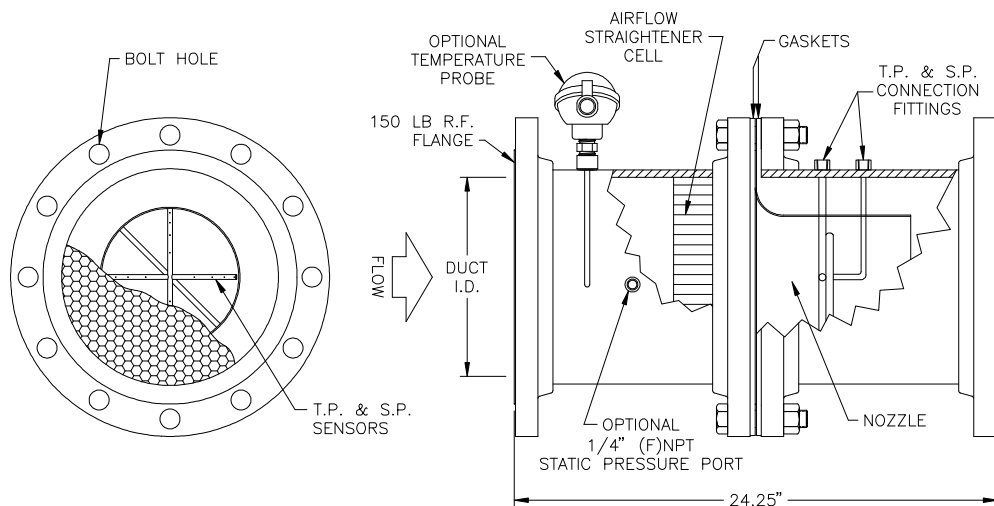

Nominal Duct Size	Duct ID	Duct Wall	Flange O.D.	Bolt Circle	Bolt Qty	Cell Hex Size	Nominal Duct Size	Duct ID	Duct Wall	Flange O.D.	Bolt Circle	Bolt Qty	Cell Hex Size
4"	4.03	0.237	9.0	7.50	8	1/4 x 3	14"	13.25	0.375	21.0	19.75	12	3/8 x 3
6"	6.07	0.280	11.0	9.50	8	1/4 x 3	16"	15.25	0.375	23.5	21.25	16	3/8 x 3
8"	7.98	0.322	13.5	11.75	8	3/8 x 3	18"	17.25	0.375	25.0	22.75	16	3/8 x 3
10"	10.02	0.365	16.0	14.25	12	3/8 x 3	20"	19.25	0.375	27.5	25.00	20	3/8 x 3
12"	12.00	0.375	19.0	17.00	12	3/8 x 3	24"	23.25	0.375	32.0	29.50	20	3/8 x 3

