

AUTO-purge III

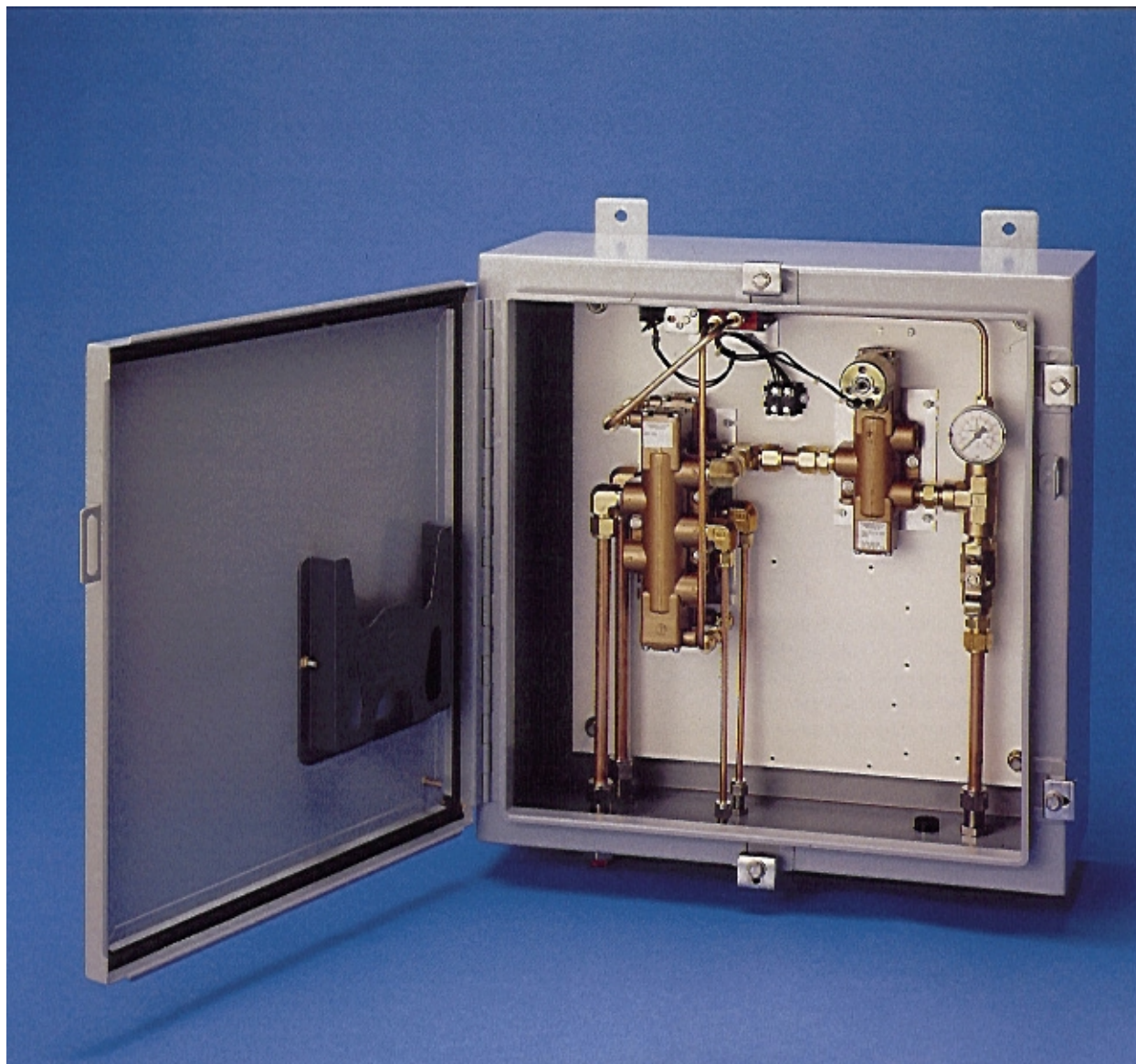

Accurate airflow measurement for demanding applications



AIR MONITOR
CORPORATION

AUTO-purge III

Product Description

Air Monitor's AUTO-purge III is designed for applications where the presence of airborne particulate might impair the measurement accuracy of Air Monitor's Combustion Air Station or VOLU-probe array. When activated by an Air Monitor "smart" flow transmitter (such as the VELTRON II, VEL-trol II, MASS-tron II, or VELTRON DPT-*plus*) or distributed control system, the AUTO-purge III

activates a combination of fail-safe valves to introduce high pressure/high volume air to the flow measuring device's sensing ports for a short duration, while simultaneously isolating the transmitter from over pressurization. This periodic purging assists in maintaining the sensing ports of the total and static pressure manifolds in a clear, unobstructed condition.

Identification Code

V-1,3 Pneumatically Piloted, 5-Way Valve, Static (low) Pressure
 V-2,4 Pneumatically Piloted, 5-Way Valve, Total (high) Pressure
 SV-1 Solenoid Operated, 5-Way Valve
 SV-2 Solenoid Operated, 3-Way Valve

HV-1 Supply Air Shut Off Valve
 PI-1,2 Gauge, Supply Air Pressure, 0-160 psig
 PRV-1 Pressure Regulator

Sequence of Operations

Automatic line purging disconnects the transmitter from the process sensing lines at regular field selectable intervals and purges the airflow station or probe array with up to 125 psig air for short periods. This periodic purging assists in maintaining the sensing orifices of the total and static pressure manifolds in a clean, unobstructed condition.

When valves V1/V3 and V2/V4 operate, velocity pressure signal lines (C and D) to the flow transmitter are isolated, and high pressure purge air (AS1) is routed via the process signal lines (A and B) to the station/probe array, cleaning the total and static pressure sensing ports.

A selectable timing sequence provided by the smart transmitter activates solenoid pilot valve SV-1 which shuttles the transmitter isolation valves (V3 and V4) and purge valves (V1 and V2). A simultaneous output signal hold corresponding to the last measured input is initiated by the transmitter and maintained until the purge cycle is complete.

At the end of the purge cycle the transmitter withdraws its purge signal, de-energizing SV-1 and causing valves V1/V2 and V3/V4 to reset after a short time delay to their normal position, thereby reconnecting the process signal lines to the transmitter. After a short timed interval the transmitter signal hold is terminated and on-line signal processing resumes.

Schematic

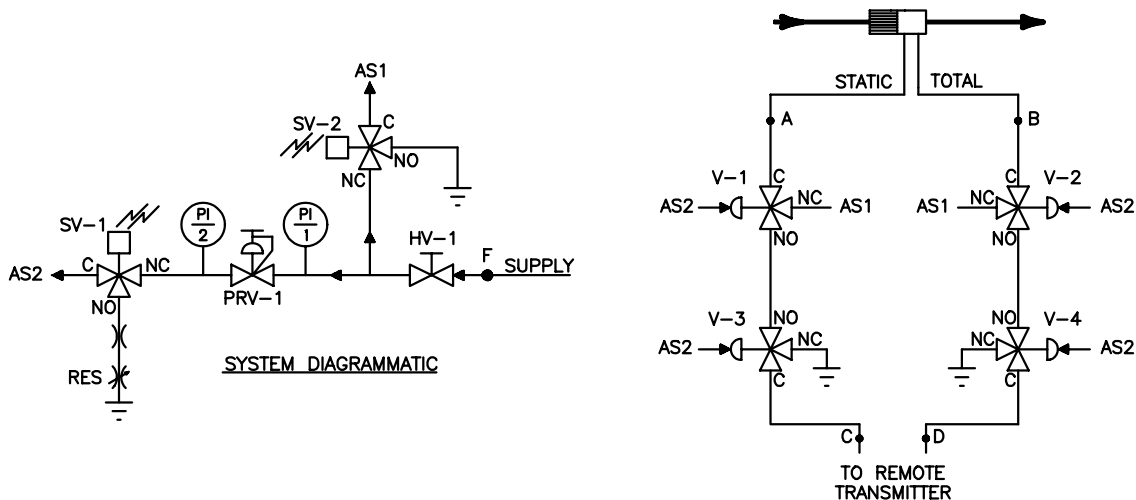

AUTO-purge III

Standard Construction

- | | |
|--|---|
| <p><input type="checkbox"/> Brass and Copper Construction</p> <ul style="list-style-type: none"> • All wetted tubing, fittings, and valves constructed of copper and/or brass. • Enclosure is NEMA 4 painted steel. • External connection fittings are stainless steel FPT. | <p><input type="checkbox"/> Stainless Steel Construction</p> <ul style="list-style-type: none"> • All wetted tubing, fittings, and valves constructed of 316 stainless steel. • Enclosure is NEMA 4 painted steel. • External connection fittings are stainless steel FPT. |
|--|---|

Optional Construction

- | | |
|---|---|
| <p><input type="checkbox"/> NEMA 4X Stainless Steel Enclosure</p> <p><input type="checkbox"/> Enclosure Heater. Requires 120VAC power supply.</p> <p><input type="checkbox"/> Vortex Cooler. Requires 80-100 psi air supply.*</p> <p><input type="checkbox"/> Continuous Enclosure Purge*</p> | <p>SV-1 & SV-2</p> <p><input type="checkbox"/> 24VAC</p> <p><input type="checkbox"/> 24VDC</p> <p><input type="checkbox"/> 120VAC</p> |
|---|---|

*These options require a 24x24 enclosure.

Dimensional Specifications

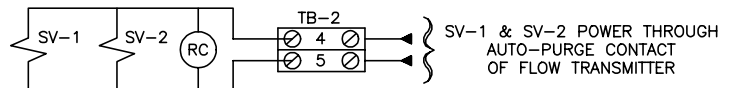
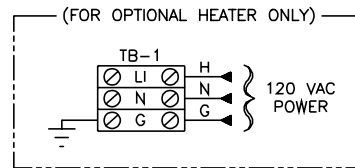
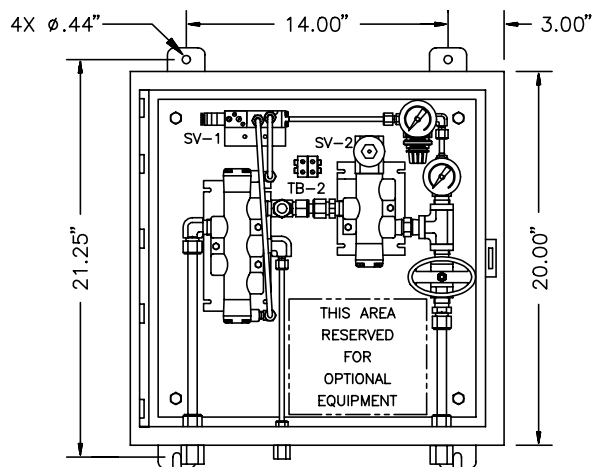

FIELD WIRING TERMINALS

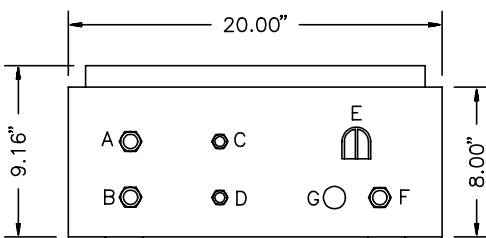

BOTTOM VIEW

CONNECTION CODE:

- | | |
|---|----------------------------------|
| A. STATIC PRESSURE, FROM FLOW STATION | $\frac{1}{2}$ " FPT |
| B. TOTAL PRESSURE, FROM FLOW STATION | $\frac{1}{2}$ " FPT |
| C. STATIC PRESSURE, TO FLOW TRANSMITTER | $\frac{1}{4}$ " FPT |
| D. TOTAL PRESSURE, TO FLOW TRANSMITTER | $\frac{1}{4}$ " FPT |
| E. CABINET VENT | |
| F. SUPPLY AIR 80-125 PSIG | $\frac{1}{2}$ " FPT |
| G. ELECTRICAL CONNECTION POWER WIRING | $\frac{3}{4}$ " K.O. (BY OTHERS) |

AUTO-purge III

Installation Guide

Air Requirement

- 80 to 125 psig at 100 CFM, oil and dirt free.
- 1 to 24 purge cycles per day, with a field selectable duration between 30 and 120 seconds during which compressed air is released.

Line Size

- If distance from AUTO-purge Panel to Flow Measuring Station or Probes is less than 25', tube size to be 1/2" O.D. Wall thickness no greater than 0.065".
- If distance from AUTO-purge Panel to Flow Measuring Station or Probes is 25' to 50', tube size to be 3/4" O.D. Wall thickness no greater than 0.065".
- If distance from AUTO-purge Panel to Flow Measuring Station or Probes is greater than 50', tube size to be 1.0" O.D. Wall thickness no greater than 0.065".

Purge Frequency

- Dependent upon the particulate concentration in each application.
- Adjustable in hourly increments; once per day the minimum frequency, and once per hour the maximum frequency.

Purge Cycle Duration

- Dependent on sensing line size, length, and routing.
- Minimum: 60 seconds.
Maximum: 120 seconds.

Ambient Temperature

- 32°F to 120°F.
- For ranges above or below this ambient temperature, use of panel heater and/or cooler is required.

Accumulator Tank (strongly recommended)

- Requires coalescing filter, pressure regulator, and check valve at the tank inlet.
 - 120 gallons - All CA stations.
 - 120 gallons - Multiple VOLU-probes having a combined length greater than 10'.
 - 80 gallons - One or more VOLU-probes having a combined length less than 10'.

Line from Accumulator Tank to AUTO-purge Panel

- 25' maximum length, 1/2" pipe (minimum).
- Recommend locating accumulator tank as close as possible to AUTO-purge Panel.

Electrical Power Requirement

- 36VA, provided via the Air Monitor smart transmitter or distributed control system's maintained activation signal.
- 120VAC, 10 amp when an optional enclosure heater is installed.

Suggested Specification

The purge system shall be capable of periodically routing 100 CFM at 80-125 psi to the flow measuring element while simultaneously isolating the flow transmitter; low pressure continuous type purges are not acceptable. A single, powered [24VAC, 24VDC or 120VAC] activation signal from a [VELTRON II, VEL-trol II, MASS-tron II, or VELTRON DPT-*plus*] smart transmitter or distributed control system will activate the purge cycle and control the purge cycle duration. The purge system will use air to open/air to close purge valves in conjunction with pneumatic fail safe control logic to

prevent transmitter overpressurization during purge system reset, loss of power, or in the event of unexpected loss of the purge control signal. The sequencing of the purge cycle shall not require the use of an onboard microprocessor or PLC. Between purge cycles, the system shall isolate the purge valves from the compressed air source.

The purge system shall be the AUTO-purge III as manufactured by Air Monitor Corporation, Santa Rosa, California.

