

CEM SYSTEMS

Continuous Emissions Monitoring



Proven solutions for a tough industry



40 CFR 75 Summary

U.S. EPA Requirements for Continuous Emissions Monitoring (CEM)

On October 26, 1992, the Environmental Protection Agency (EPA) signed into law Part 75 of the Code of Federal Regulations governing Continuous Emission Monitoring. First proposed in December 1991 and subjected to extensive public review, the finalized version of 40 CFR 75 follows. The full version of 40 CFR 75 outlines the purpose, standards, certification process, and recordkeeping requirements for monitoring seven emission parameters:

SO ₂ concentration	Opacity
CO ₂ concentration	Volumetric flow
NO _x concentration	Diluent concentration (O ₂ or CO ₂)
Moisture concentration	

Volumetric Flow Monitoring Systems

Prior to receiving certification by the EPA, a flow monitoring system must satisfy continuous emission monitoring requirements via a detailed test procedure to verify that the performance and system configuration is within the EPA mandated requirements relative to:

Measurement Location
Interference Check
Calibration Error
Relative Accuracy
Bias

Measurement Location

EPA defines an appropriate location for installation of a CEM System by referencing 40 CFR 60, Appendix A, Method 2. The desired location would be one with a minimum of eight stack or duct diameters downstream and two diameters upstream of any flow disturbance. Minimum siting requirements are two

downstream diameters and one-half upstream diameter of any flow disturbances. Provisions are made in 40 CFR 75 to petition the EPA for an alternate monitoring location when the minimum site requirements cannot be met.

Interference Check

Regardless of the technology used to measure flow, all flow monitoring systems must include a means to ensure the in-stack equipment remains free of obstructions that would affect ongoing measurement accuracy. For differential pressure flow

monitors, the requirement is for an automatic timed, periodic back purge using compressed air to keep the probe sensing ports clean and expel condensation of wet gases. Air Monitor meets this requirement with its AUTO-purge/CEM System.

Calibration Error

Calibration error is calculated as the percentage differential between a reference value and the actual monitor instrumentation reading. Calibration error must be determined during the certification process, then daily, and periodically thereafter. The daily check of calibration must verify that the error has not deviated more than 3.0 percent from the reference

value, with excessive deviation necessitating instrumentation recalibration. Air Monitor's instrumentation, consisting of its MASS-tron/CEM transmitter with AUTO-cal function, provides daily reporting of calibration flow outputs for calculation of calibration error in the DAS.

Relative Accuracy

Effective January 1, 2000 the accuracy requirement for volumetric flow was lowered to 10%. Flow monitors achieving a relative accuracy of 7-1/2% were granted a reduction in RATA testing frequency from semi-annually to annually.

Correct selection of probe location and quantity, combined with field calibration prior to certification permits the Air Monitor flow monitoring system to achieve **annual** RATA frequencies.

RATA FREQUENCY REQUIREMENTS FOR FLOW MONITORING SYSTEMS	
Relative Accuracy	Required RATA Frequency
10.0%	Semi-Annual
7.5%	Annual

Bias

Bias is a systematic error resulting in measurements that will be consistently low or high relative to the true flow measurement. Flow monitors that exhibit the need for low bias will not pass

certification. Flow monitors that exhibit the need for high bias can have the monitor output values adjusted by a single correction factor.

System Components

To assist in complying with the Clean Air Act's stringent emission measurement standards, Air Monitor has assembled a cost effective integrated system consisting of in-stack flow

measurement equipment and companion instrumentation to provide continuous, accurate, and reliable volumetric flow monitoring for stacks and ducts of any size and configuration.

In-Stack Flow Traverse Probe(s)

Required is the means to accurately monitor the average flow rate and temperature of the stack emissions. Flow rate monitoring is performed by sensing individual flow components at multiple points (traversing) across one or more diameters for circular stacks or along multiple parallel traverses for rectangular stacks, and averaging the obtained values. Average temperature measurement is achieved using one or more temperature probes to obtain a single full traverse of a stack.

The Air Monitor STACK-probe is an airflow traverse probe based on differential pressure (Pitot-Fechheimer) technology for measuring airflow; the same technology that will be used during the certification process to verify relative accuracy of the flow monitoring system. Each STACK-probe consists of two separate round tube self-averaging manifolds; one to measure the stack total pressure, and the other to measure stack static pressure. Multiple Pitot-Fechheimer ports are positioned on each manifold on an equal area basis (for rectangular stacks) or on an equal concentric area (for circular stacks). Similarly, average stack temperature is measured using a temperature probe with multiple sensing elements spaced along the probe length.

The engineered truss type design of the STACK-probe utilizes tubular structural materials welded to a 6", 150# raised face



pipe flange, permitting cantilever probe mounting in even extremely large stacks. Standard Type 316 stainless steel construction ensures long-term durability and continuing accuracy in most installations, with materials such as Hastelloy C22 and Inconel available for extreme temperature and/or severely corrosive applications.

As a basic instrument, the STACK-probe does not require any initial or periodic calibration to measure flow accurately. As a passive device with no moving parts or active electrical circuits, removal of the STACK-probe from the stack after installation for repair or calibration is not required.

Probe Back Purge

Required for differential pressure flow monitoring systems is a back purging means to ensure that the in-stack flow monitor probe has its pressure sensing ports and averaging manifold maintained free of particulate build-up and vapor condensation.

When activated by Air Monitor's MASS-tron/CEM or the Data Acquisition System (DAS), the AUTO-purge/CEM System sequentially operates a combination of failsafe valves to automatically back purge the sensing lines and the STACK-

probes with high volume/high pressure compressed air for a short duration, while simultaneously isolating the transmitter from over-pressurization.

Standard AUTO-purge/CEM construction mounts all components in a steel NEMA 4 rated enclosure, with all wetted parts made of copper or brass. The AUTO-purge/CEM is optionally available in a stainless steel NEMA 4X enclosure, with stainless steel wetted parts for corrosive applications.

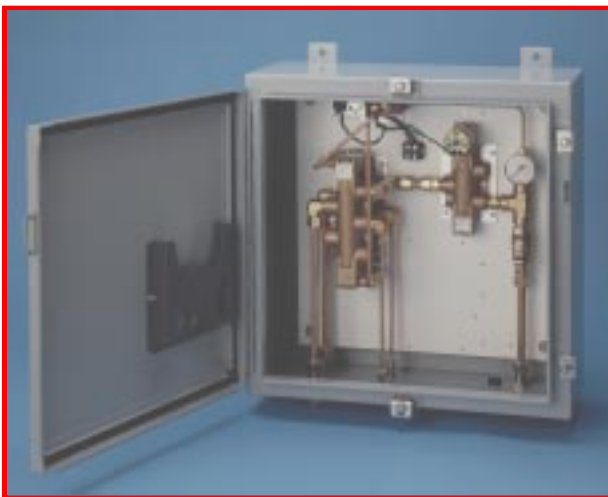

AUTO-purge/CEM



MASS-tron/CEM

Data Reporting & Installation Requirements

Data Reporting

The Air Monitor MASS-tron/CEM multi-variable, ultra-low differential pressure transmitter converts the temperature and differential pressure flow signals received from the in-stack traverse probe(s) into a continuous output signal representing the volumetric flow in SCFM (wet or dry basis) being discharged into the atmosphere.

To meet the calibration error reporting requirements of 40 CFR 75, the MASS-tron/CEM used in stack flow monitoring applications is equipped with AUTO-cal circuitry. Once every 24 hours, the MASS-tron/CEM executes an AUTO-cal calibration cycle, during which the transmitter output signal is held at the last sensed flow level. Sequentially activated valves expose the MASS-tron/CEM transmitter to reference pressures for zero and span resulting in corresponding calibration flow outputs, after which the MASS-tron/CEM resumes normal flow monitoring.

In addition to the local display of information, the MASS-tron/CEM provides outputs to the Data Acquisition System (DAS) for:

Temperature °F	4-20mADC
AUTO-cal Acknowledgment	Dry Contact
AUTO-purge Acknowledgment	Dry Contact
SCFM	4-20mADC*
Zero Calibration Error Signal	4-20mADC*
Span Calibration Error Signal	4-20mADC*

*Serial Output. See Figure below.

The MASS-tron/CEM is available in either a 19" rack mount or a NEMA 4 enclosure, with a NEMA 4X stainless steel enclosure optionally available.

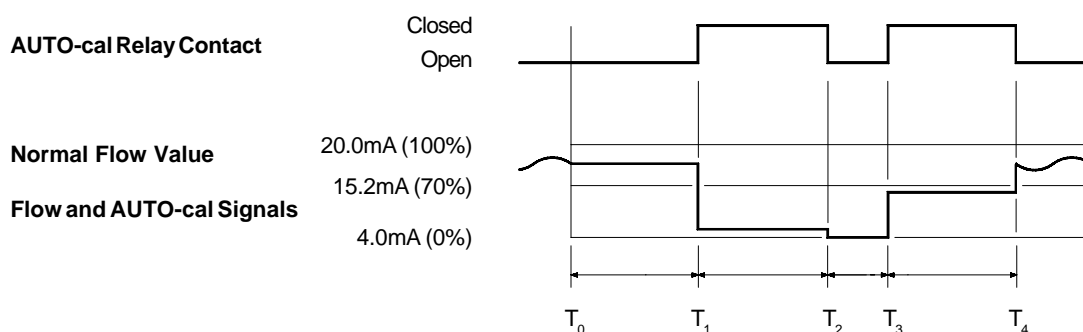

- T₀ MASS-tron/CEM internal timer or external dry contact from DAS initiates AUTO-cal cycle. Transmitter output signal for stack flow is held at the last flow value during the AUTO-cal cycle.
- T₁ AUTO-cal relay contact closes. Zero flow output signal begins.
- T₂ AUTO-cal relay contact opens. Flow output signal goes to 4mADC.
- T₃ AUTO-cal relay contact closes. Calibration flow output signal begins.
- T₄ AUTO-cal relay contact opens. Calibration flow output signal ends. Transmitter returns to reporting actual stack flow.

Installation Requirements

Purge Air Requirement. 80 to 125 psig at 100 CFM, oil and dirt free. 1 to 24 purge cycles per day, with a duration of less than 2 minutes during which compressed air is released.

Instrument Air Requirement. 25 to 120 psig instrument air supply. Per ISA S7.3, required for AUTO-span equipped MASS-tron/CEM.

Ambient Temperature. 32°F to 140°F for the AUTO-purge/CEM panel; 60°F to 80°F for the MASS-tron/CEM. Recommended installation is within the environmentally controlled analyzer instrumentation shelter.

Accumulator Tank (strongly recommended). Requires coalescing filter, pressure regulator, and check valve at the tank inlet.

1 stack traverse	–	80 gallons
2 stack traverses	–	120 gallons

Electrical Power Requirements. 120VAC, 10 amp for heater equipped AUTO-purge/CEM panel; 120VAC, 1 amp for MASS-tron/CEM.

Line from Accumulator Tank to AUTO-purge/CEM Panel. 25' maximum length, 1/2" pipe (minimum). Recommend locating accumulator tank as close as possible to AUTO-purge/CEM panel.

Line Size from AUTO-purge/CEM to STACK-probe.

Distance	< 25'	25' to 50'	> 50'
Tube Size	1/2" S.S. tube	3/4" S.S. tube	1" S.S. tube

Line from AUTO-purge/CEM Panel to MASS-tron/CEM Panel. Via pre-manufactured umbilical or SS tubing.

Distance	< 25'	25' to 200'	> 200'
Tube Size	1/4" S.S. tube	3/8" S.S. tube	1/2" S.S. tube

Typical Installation

STACK-probe w/Temperature and Insert Port

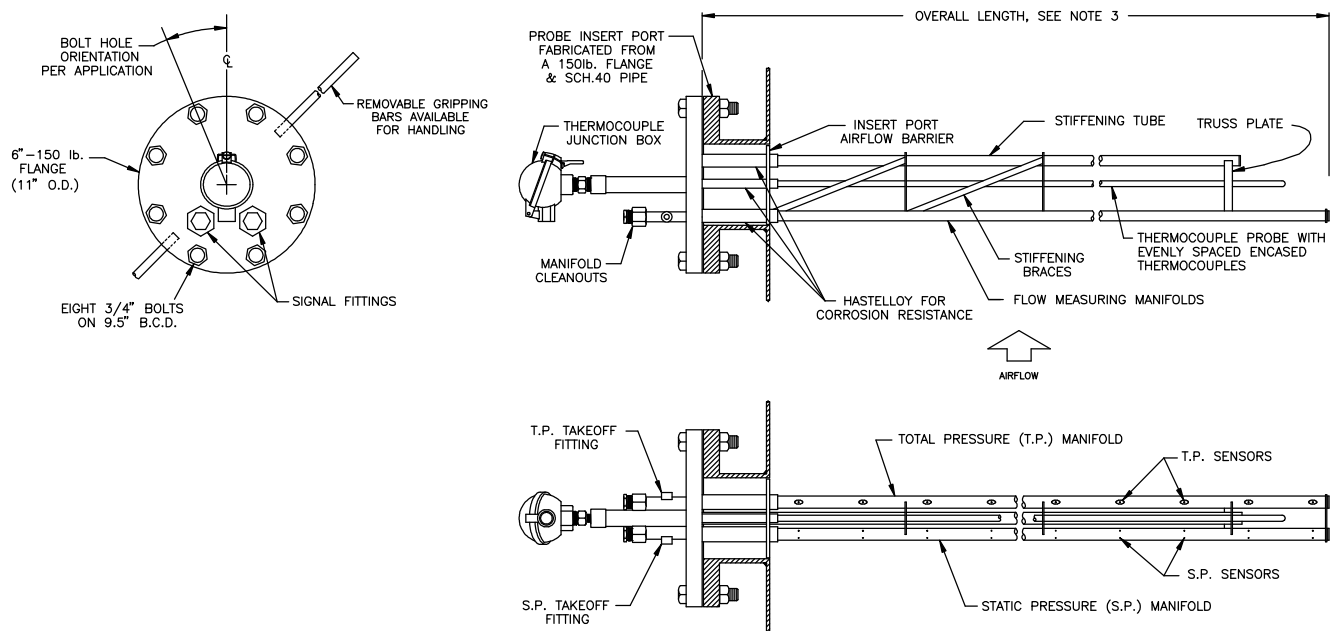

In-Stack Probe Configurations – Single-Wall Stacks

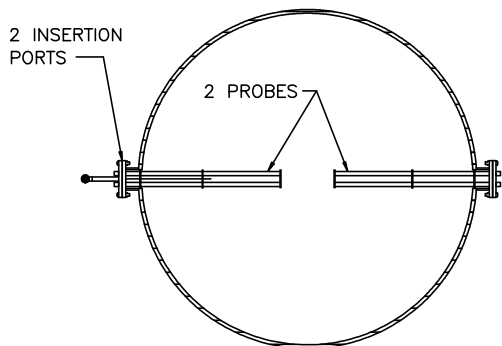

TWO CANTILEVERED STACK-probes
(ONE WITH TEMPERATURE SENSOR)

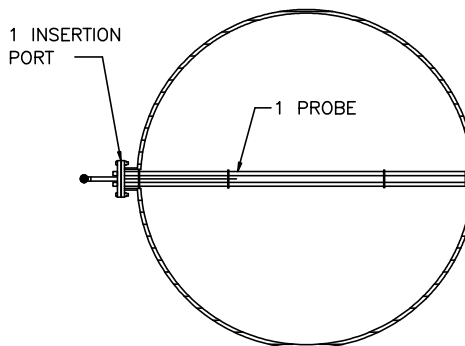

ONE FULL-LENGTH STACK-probe
(WITH TEMPERATURE SENSOR)

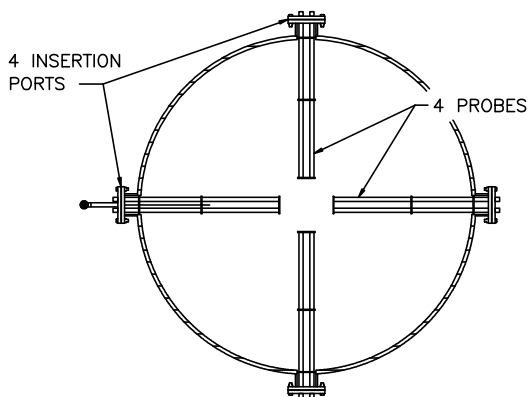

FOUR CANTILEVERED STACK-probes
(ONE WITH TEMPERATURE SENSOR)

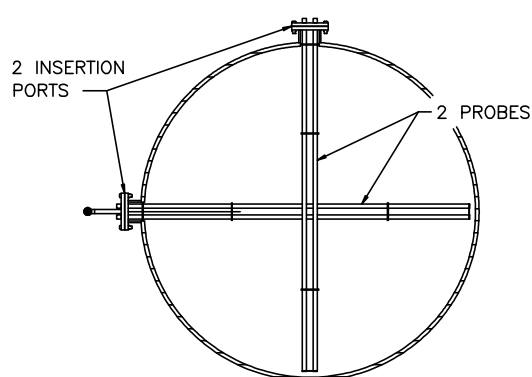

TWO FULL-LENGTH STACK-probes
(ONE WITH TEMPERATURE SENSOR)

Typical Installation

Dual Traverse Schematic

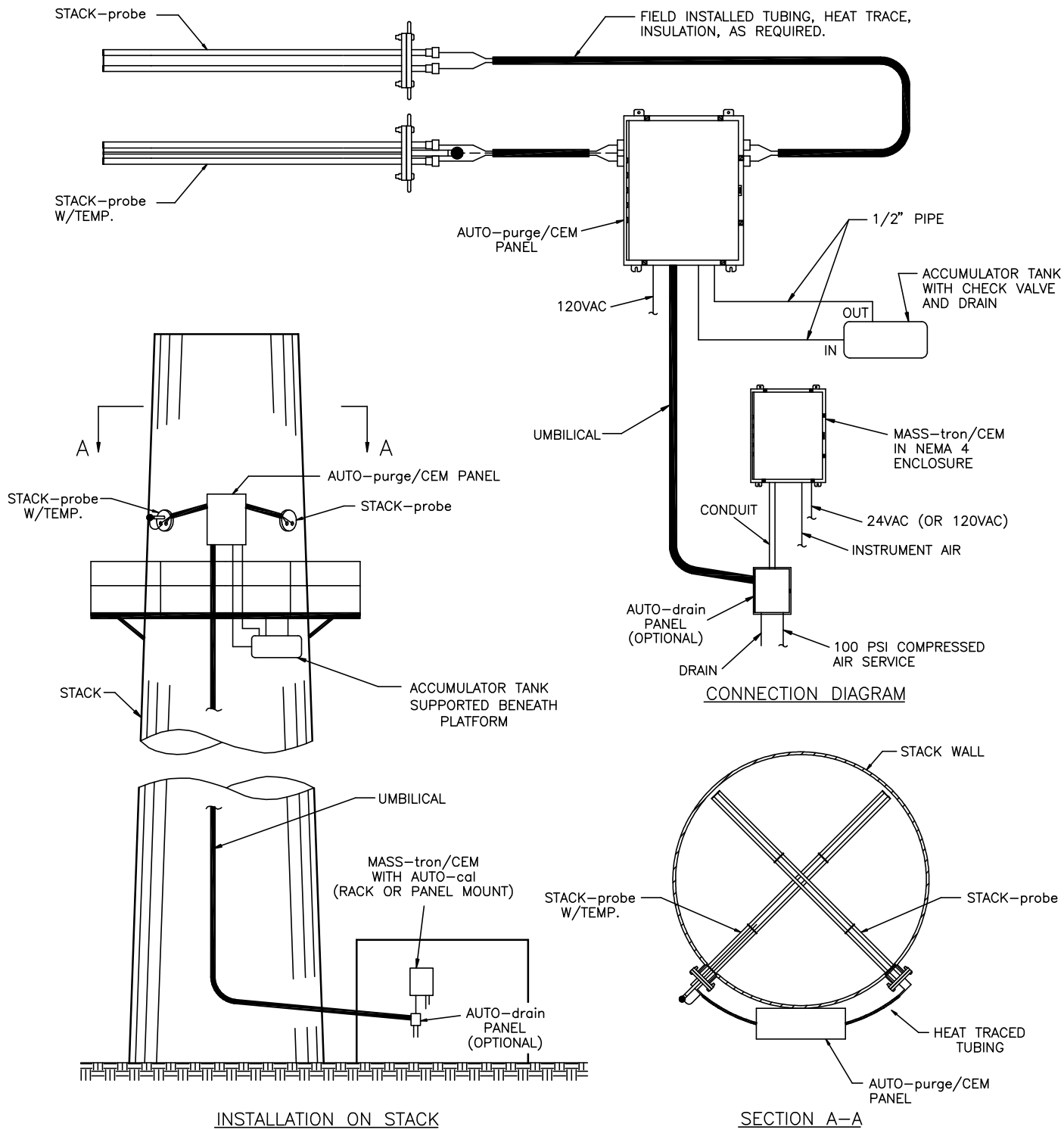

AUTO-purge/CEM Located on the Stack Platform
 MASS-tron/CEM Located in the Instrumentation Enclosure

Air Monitor's Product Families of Air & Coal Flow Measurement Systems



VOLU-probe/SS™ Stainless Steel Airflow Traverse Probes

Multi-point, self-averaging, Pitot-Fechheimer airflow traverse probes with integral airflow direction correcting design. Constructed of Type 316 stainless steel and available in externally and internally mounted versions for harsh, corrosive or high temperature applications such as fume hood, laboratory exhaust, pharmaceutical, and clean room production and dirty industrial process applications.



IBAM™ – Individual Burner Airflow Measurement

The IBAM™ – Individual Burner Airflow Measurement probe is ideally suited for new or retrofit applications where a reduction in plant emissions and improvement in efficiency can be obtained through accurate measurement of burner secondary airflow. The IBAM™ probe has been designed to accurately measure in the particulate laden, high operating temperature conditions found in burner air passages.



CAMS™ – Combustion Airflow Management System

The CAMS™ – Combustion Airflow Management System has been designed to reliably and accurately measure airflow in combustion airflow applications. The CAMS™ contains the microprocessor based instrumentation to measure the airflow and manage the AUTO-purge. The AUTO-purge is a high pressure air blowback system that protects the duct mounted flow measurement device from any degradation in performance due to the presence of airborne particulate (flyash).



Combustion Airflow Measuring Station & VOLU-probe/SS™ Traverse Probes

Air Monitor's duct mounted airflow measurement devices have been designed to accurately and repeatedly measure air mass flow in power plants. The Combustion Air (CA) Station™ includes honeycomb air straightener to accurately measure in shorter straight duct runs than any other flow measurement device. The VOLU-probe/SS™ delivers accurate airflow measurement performance in the form of an insertion probe. Both devices feature Type 316 stainless steel flow sensing arrays.

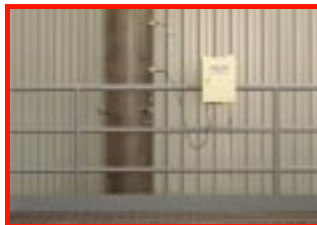

Pf-FLO™ – Pulverized Fuel Flow Management

The Pf-FLO™ system performs continuous and accurate fuel flow measurement in pulverized coal fired combustion applications, providing boiler operators with the real-time data needed to balance coal mass distribution between burners. Balanced fuel improves combustion efficiency and lowers emissions while reducing in-furnace slagging, coal layout, fuel slagging, and coal pipe fires.

Engineering & Testing Services. Air Monitor offers complete engineering and testing to analyze air and coal delivery systems. Air Monitor's field testing services use 3D airflow traversing and Pf-FLO coal flow measurement systems for the highest possible accuracy. To ensure cost effective and accurate solutions, Air Monitor has full scale physical flow modeling capability and in house Computational Fluid Dynamics (CFD). CFD analysis is used to analyze flow profiles and design/redesign ductwork to improve overall performance. Full scale model fabrication and certified wind tunnel testing is used to develop application specific products that will measure accurately where no standard flow measurement can.

