

VOLU-probe/SS

Stainless Steel Pitot Airflow Traverse Probes

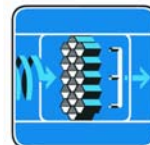

Accurate airflow measurement for demanding applications



**AIR MONITOR
CORPORATION**

VOLU-probe/SS

Product Description

The VOLU-probe/SS Stainless Steel Pitot Airflow Traverse Probe is ideally suited for new installations or retrofit applications requiring accurate airflow measurement in locations having limited straight duct runs. Multiple sets of total and static pressure sensing ports along the entire length of the VOLU-probe/SS traverse the airstream in a single line across the duct, and average the sensed pressures in separate manifolds. An array of VOLU-probe/SS

probes are used to properly sense the typically stratified flow to provide an equal area traverse of an entire duct cross-section. The VOLU-probe/SS is suited for clean or harsh and particulate laden applications, operating at temperatures ranging from -20 to 900°F. As a primary flow sensing means, the VOLU-probe/SS can be used in industrial process applications ranging from power generation (combustion airflow), fiber quenching, process drying, emission monitoring, etc.

How It Works

The VOLU-probe/SS operates on the Fechheimer Pitot derivative of the multi-point, self-averaging Pitot principle to measure the total and static pressure components of airflow. Total pressure sensing ports, with chamfered entrances to eliminate air direction effects, are located on the leading surface of the VOLU-probe/SS to sense the impact pressure (P_t) of the approaching airstream (see Figure 2). Fechheimer pair of static pressure sensing ports, positioned at designated angles offset from the flow normal vector, minimize the error inducing effect of directionalized airflow. As the flow direction veers from the normal, one static sensor is exposed to a higher pressure ($P_s + \text{part of } P_t$), whereas the other

static sensor experiences a lower pressure ($P_s - \text{part of } P_t$) of the same magnitude, thereby canceling out the undesired effect of partial total pressure (P_t). It is this unique design of offset static pressure and chamfered total pressure sensors (see Figure 1) that make the VOLU-probe/SS insensitive to approaching multi-directional, rotating airflow with yaw and pitch up to 30° from straight flow, thereby assuring the accurate measurement of the sensed airflow rate without the presence of an airflow straightener upstream. This unique design of the VOLU-probe/SS is covered by U.S. Patent No. 4,559,835.

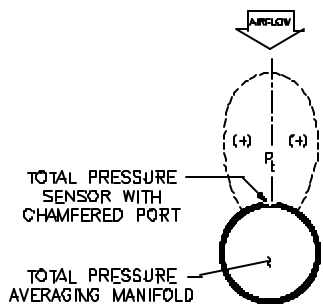

Figure 1

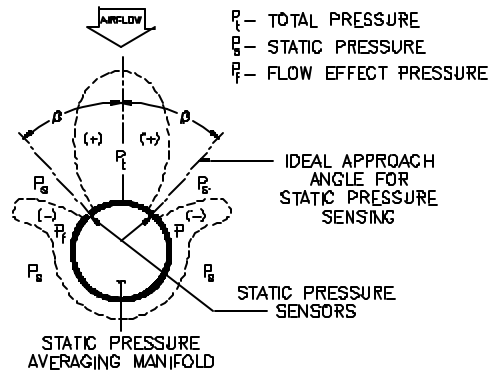
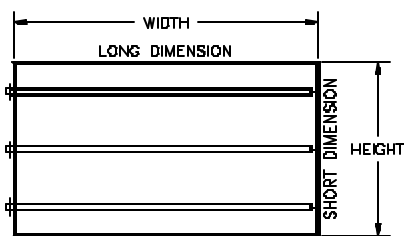

Figure 2

Accuracy

All recognized flow measurement standards (ASHRAE Fundamentals, AMCA Publication 203, Industrial Ventilation Manual, 40CFR60, etc.) agree that accurate airflow measurement is highly dependent upon the quantity and pattern of sensing points in the airstream, and the relative position of the sensing points to upstream/downstream flow disturbances.

When installed per Air Monitor's Minimum Installation Requirements (see back page), the minimum quantity and placement of VOLU-probe/SS airflow traverse probes shown below will produce assured measuring accuracies of $\pm 2-3\%$ of actual airflow.



FOR SQUARE AND RECTANGULAR DUCT

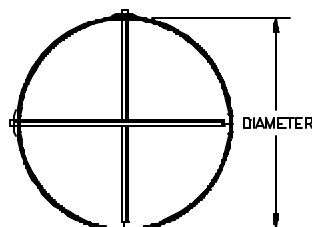

FOR CIRCULAR DUCT

HEIGHT DIMENSION	MINIMUM QTY. OF VOLU-probes RECOMMENDED	HEIGHT DIMENSION	MINIMUM QTY. OF VOLU-probes RECOMMENDED
8" TO 12"	1	>54" TO 84"	4
>12" TO 30"	2	>84" TO 120"	5
>30" TO 64"	3	>120" TO 180"	6

DIAMETER	MINIMUM QTY. OF VOLU-probes RECOMMENDED
6" TO 18"	1
>18" TO 72"	2
>72" +	3

VOLU-probe/1SS & 2SS

VOLU-probe/1SS – Externally Mounted

The VOLU-probe/1SS is designed for mounting in ducts or stacks by drilling two holes in opposing walls, without the need to enter those structures.

The VOLU-probe/1SS is furnished with a threaded end support, gasketed washer and nut, and a mounting plate with signal take-off FPT connections, all fabricated of type 316 stainless steel.

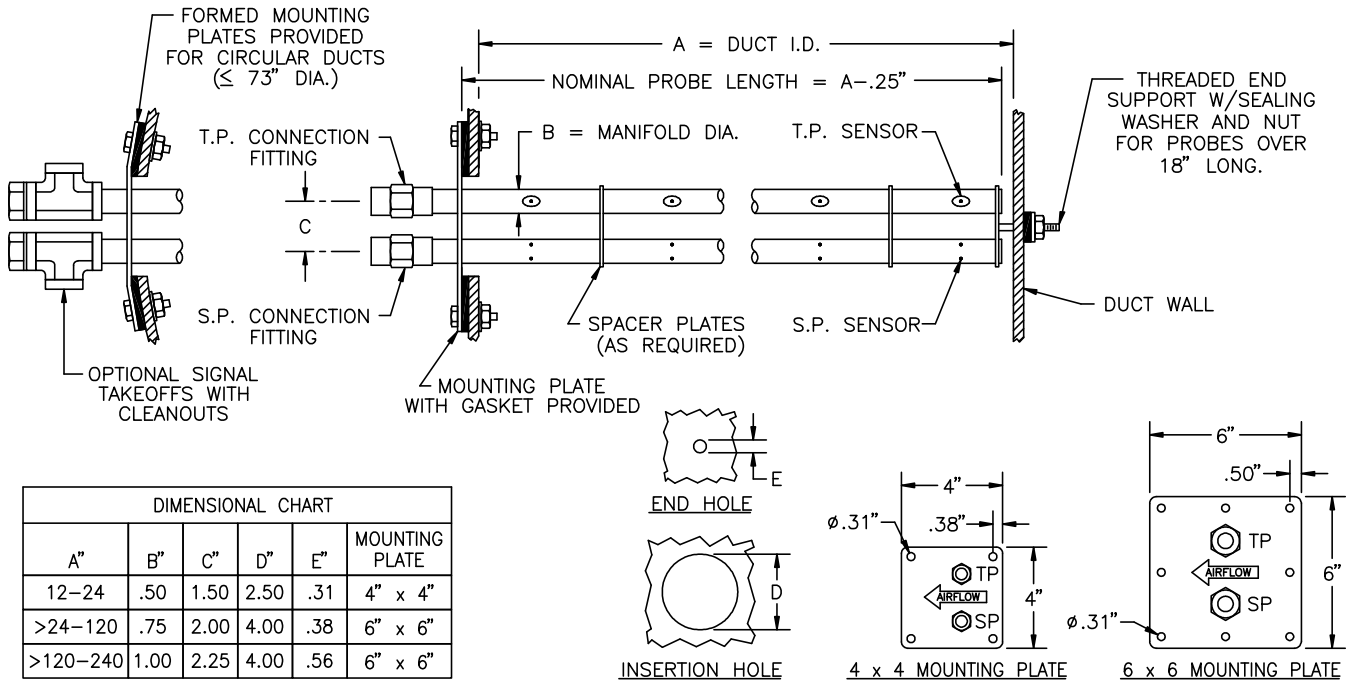

VOLU-probe/2SS – Internally Mounted

The VOLU-probe/2SS is designed for larger ducts or stacks where the size permits entry for installation, or where duct external accessibility or clearance is insufficient to permit probe mounting from outside the duct.

The VOLU-probe/2SS is furnished with interior mounting and end support plates, and midpoint signal take-off FPT connections, all fabricated of type 316 stainless steel.

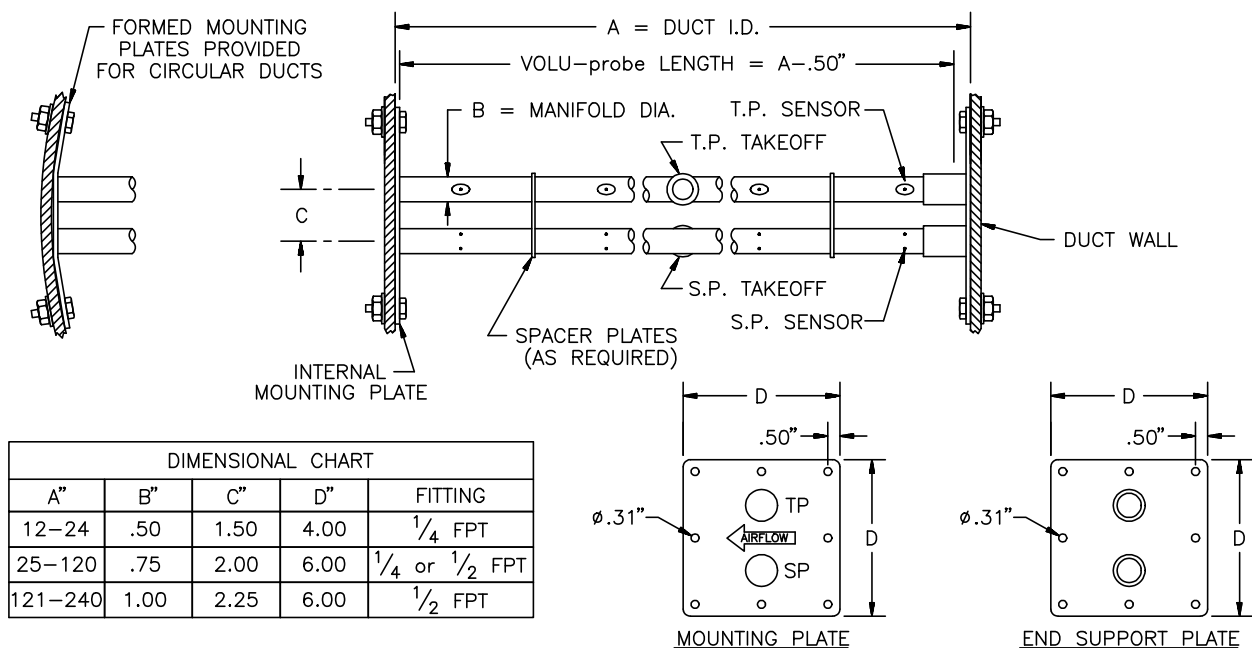

VOLU-probe/SS Options

VOLU-probe/SS – Construction Options

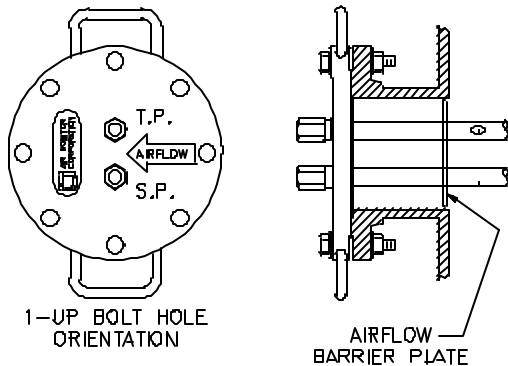

1-UP BOLT HOLE ORIENTATION

AIRFLOW BARRIER PLATE

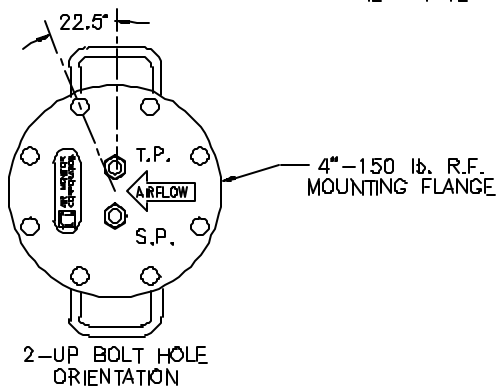

2-UP BOLT HOLE ORIENTATION

4" - 150 lb. R.F. MOUNTING FLANGE

150 lb. Mounting Flange

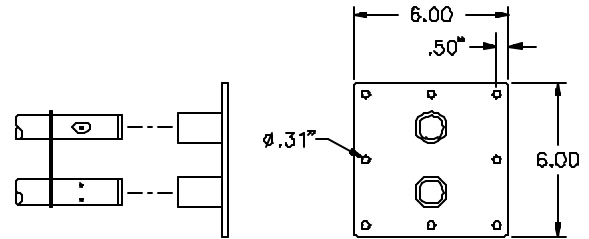

SOCKET

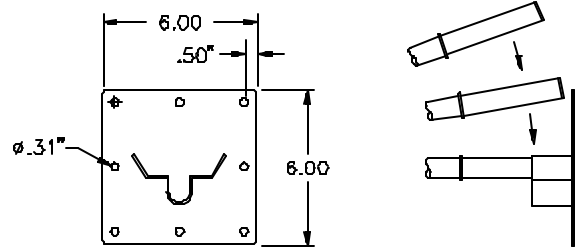

Y-SHAPED

Probe End Supports

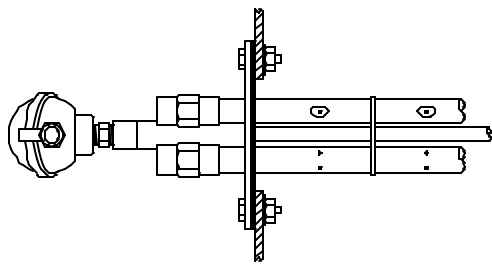

WITH STANDARD MOUNTING PLATE

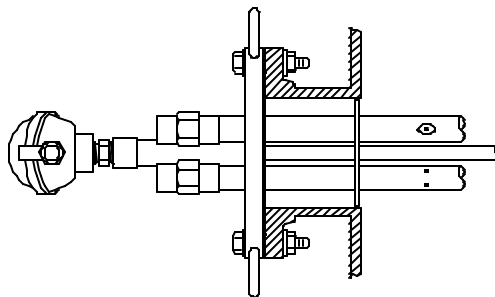

WITH 150lb MOUNTING FLANGE

Temperature Probe

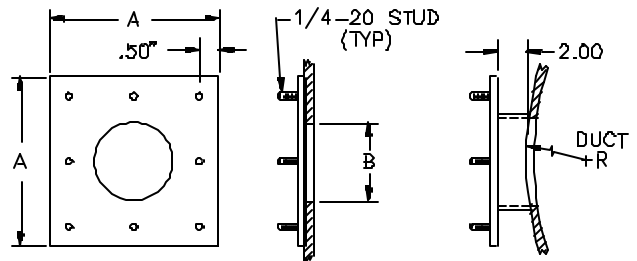

STANDARD

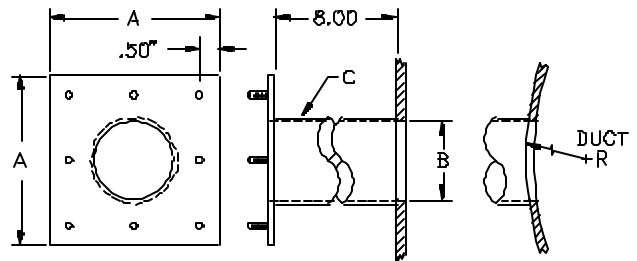

EXTENDED

DIMENSIONAL CHART			
PROBE LENGTH	A"	B"	C (PIPE)
12-24	4.00	Ø2.00	2" SCH 40
25-240	6.00	Ø4.00	4" SCH 40

Companion Mounting Plates

Stainless Steel Airflow Traverse Probes

Construction Features

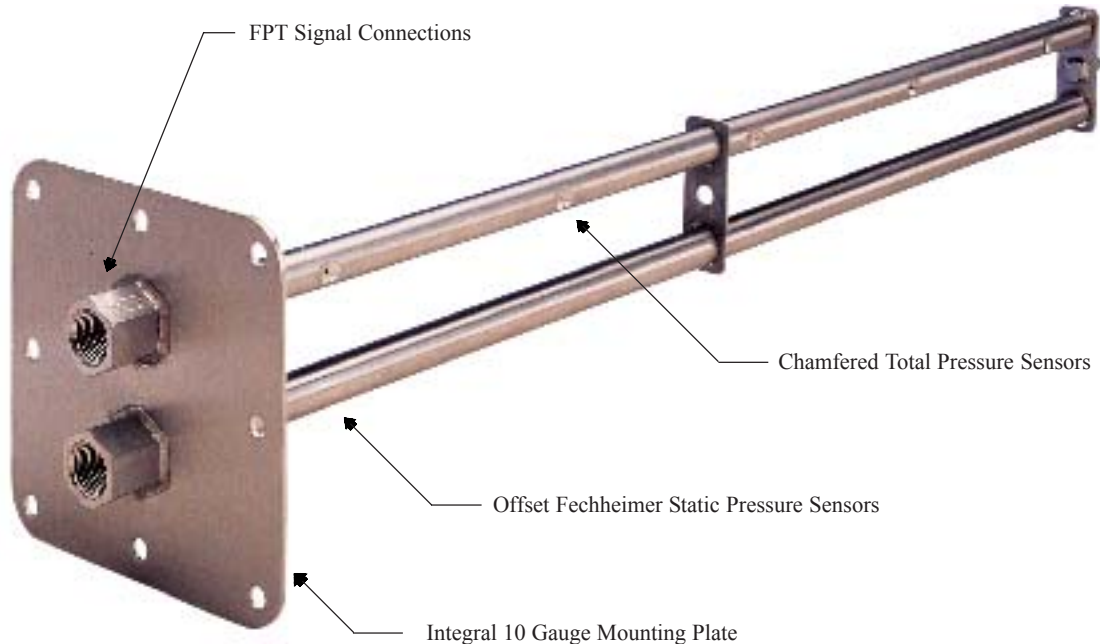

Features

No Air Straighteners Required. The VOLU-probe/SS unique dual offset static pressure sensor and patented chamfered total pressure sensor design permit the accurate measurement of the airflow rate in highly turbulent flow locations (with directional yaw and pitch varying up to 30° from the duct's longitudinal axis) without the need for upstream air straightening means.

Offered in Two Models. The VOLU-probe/SS is offered in two basic configurations to facilitate installation in new or existing ducts or stacks; the Model 1 for external mounting, and the Model 2 for internal mounting.

Negligible Resistance to Airflow. The VOLU-probe/SS cylindrical configuration and smooth surface free of external sensor protrusions permit the airstream to flow unrestricted around and between the installed traverse probes, creating a very minimal, if not negligible resistance to airflow (Ex: 0.046 IN w.c. at 2000 fpm air velocity).

Performs Equal-Weighted Averaging of Flow Signals. Through the use of separate averaging manifolds, the VOLU-probe/SS instantaneously averages, on an equal-weighted basis, the multiple pressures sensed along the length of the probe, producing separate "averaged" total pressure and static pressures at the probe's external signal connections.

Provides for Equal Area Traverse. Each VOLU-probe/SS contains multiple total and static pressure sensors specifically and precisely located along the length of the probe to provide an equal area traverse of ducted airflow. For rectangular duct configurations, the sensors are spaced at equal distances along the probe. For circular duct configurations, the sensors are located at the centers of the equivalent concentric area along the probe.

True Velocity Pressure Measurement. The total and static pressure components of airflow measured by the VOLU-probe/SS can be directly converted in velocity pressure (and velocity) without the use of correction factors, thereby facilitating flow verification with a Pitot tube or other hand held instrumentation.

No Sensor Protrusions. The VOLU-probe/SS total and static pressure sensors are all contained within the confines of the external surface of the probe. There are no protruding sensors to be bent, broken, or otherwise damaged during installation or possible subsequent removal for inspection or cleaning.

Rugged Construction Assures Long Service Life. The standard VOLU-probe/SS is fabricated from Type 316 stainless steel using all welded construction. See Page 4 for construction options, and contact Factory for alternate materials of construction such as Hastelloy, Inconel, Kynar, PVC, etc.

VOLU-probe/SS

Minimum Installation Requirements

Note: VOLU-probe/SS locations shown are **not** ideal. The locations indicate the **minimum** clearance required from air turbulence producing sources. Wherever possible, the VOLU-probe/SS should be installed where greater runs of straight duct (or clearances) than shown below exist.

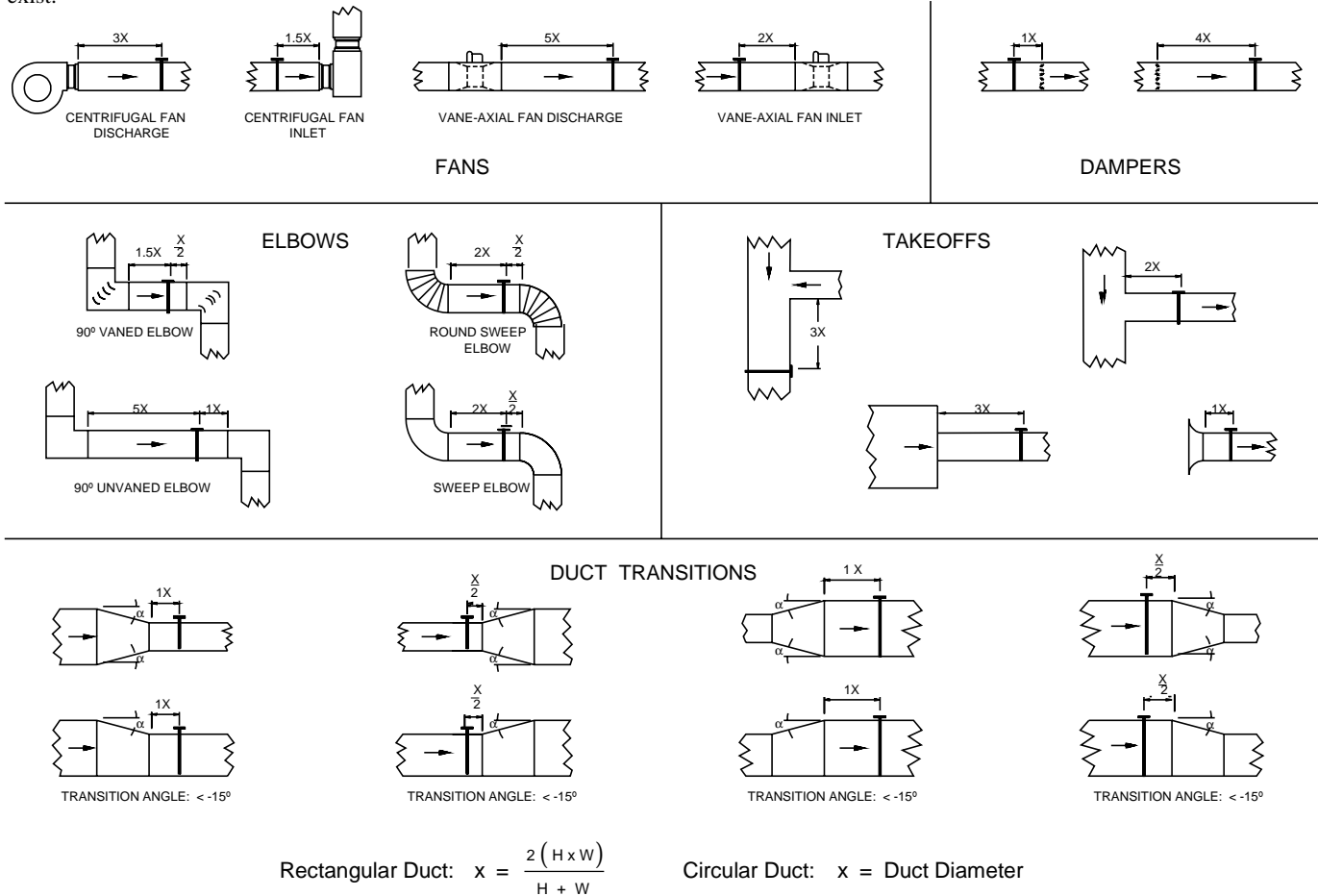

Suggested Specification

Provide where indicated an array of airflow traverse probes capable of continuously monitoring the stack or duct capacities (air volumes) it serves.

Each airflow traverse probe shall contain multiple total and static pressure sensors and internally connected to their respective averaging manifolds. The flow sensors shall not protrude beyond the surface of each probe, and shall be the offset (Fechheimer) type for static pressure and the chamfered impact type for total pressure measurement. The airflow sensing probe's measurement accuracy shall not be affected by directional flow having pitch and/or yaw angles up to 30°.

Each airflow traverse probe shall be fabricated of type 316 stainless steel, all welded construction, and shall be furnished with the flat or curved plate mounting means. In addition, access ports and accessory hardware shall be provided to facilitate external

installation of the probe and end support (if required), yet permitting easy probe removal for inspection, etc.

The airflow traverse probe shall not induce a pressure drop in excess of 0.046 IN w.c. at 2000 FPM, nor measurably contribute to sound levels within the duct. Total and static pressure sensors shall be located at the centers of equal areas (for rectangular duct) or at equal concentric area centers (for circular ducts) along the probe length. The airflow traverse probe shall be capable of producing steady, non-pulsating signals of total and static pressure without need for flow corrections or factors, with an accuracy of 2-3% of actual flow, over a velocity range of 400 to 4000 FPM.

The airflow traverse probe(s) shall be the VOLU-probe [1SS, 2SS] as manufactured by AMC Power, Santa Rosa, California.

