

VEL-trol II

ULTRA-LOW RANGE DIFFERENTIAL PRESSURE/ FLOW TRANSMITTER / CONTROLLER

PHYSICAL SPECIFICATIONS

Signal Connections. High and low pressure, 1/8" FPT.
Electrical Connections. External terminal strip with plug-in connectors. Optional terminal strip enclosure with dual 3/4" conduit connections.
Enclosure. NEMA 1 aluminum enclosure.
Weight. 4.1 lbs.

DIMENSIONAL SPECIFICATIONS

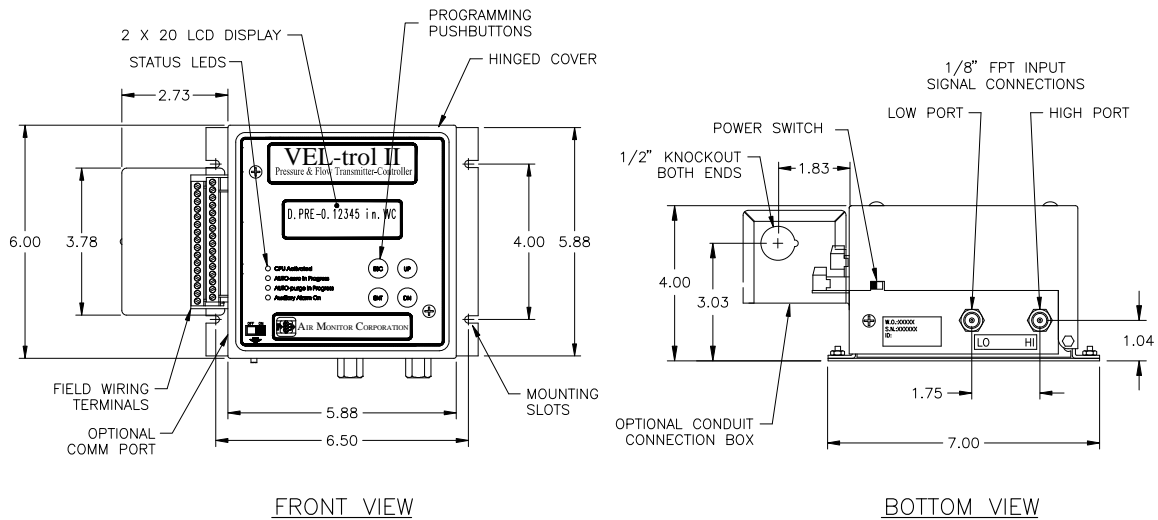

WIRING DIAGRAM

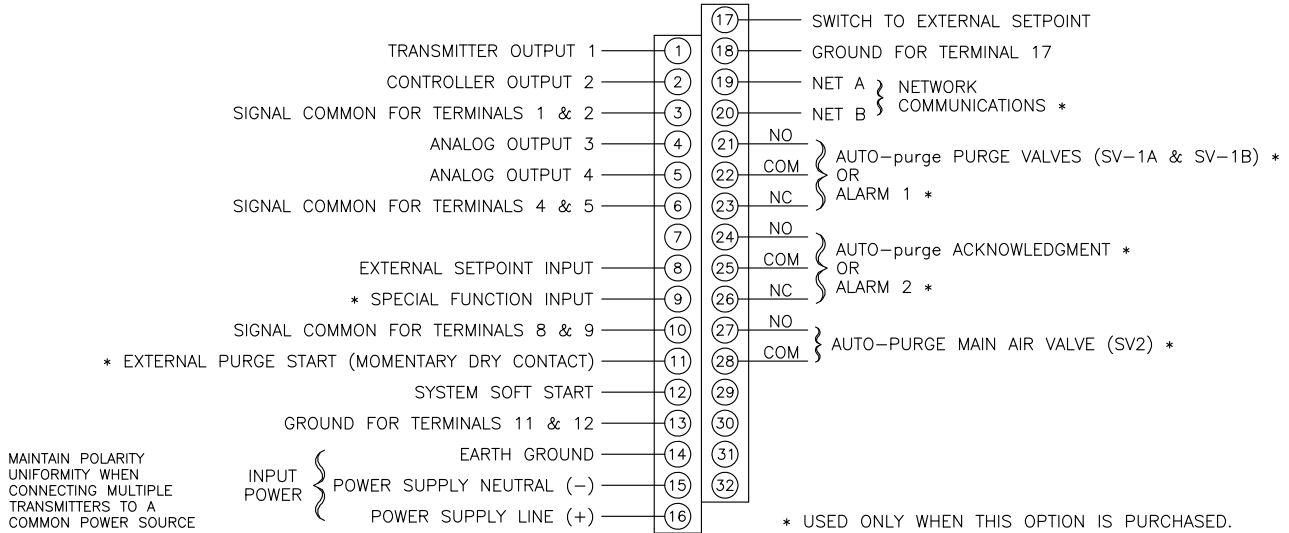

MAINTAIN POLARITY UNIFORMITY WHEN CONNECTING MULTIPLE TRANSMITTERS TO A COMMON POWER SOURCE