

DCAS

Data Center Aisle Sentry Installation and Operation Manual



SAFETY INFORMATION

The DCAS system was calibrated at the factory before shipment. To ensure correct use of the system, please read this manual thoroughly.

Regarding this Manual:

- This manual should be passed on to the end user.
- Before use, read this manual thoroughly to comprehend its contents.
- The contents of this manual may be changed without prior notice.
- All rights reserved. No part of this manual may be reproduced in any form without Air Monitor's written permission.
- Air Monitor makes no warranty of any kind with regard to this material, including, but not limited to, implied warranties of merchantability and suitability for a particular purpose.
- All reasonable effort has been made to ensure the accuracy of the contents of this manual. However, if any errors are found, please inform Air Monitor.
- Air Monitor assumes no responsibilities for this product except as stated in the warranty.
- If the customer or any third party is harmed by the use of this product, Air Monitor assumes no responsibility for any such harm owing to any defects in the product which were not predictable, or for any indirect damages.

SAFETY PRECAUTIONS:

The following general safety precautions must be observed during all phases of installation, operation, service, and repair of this product. Failure to comply with these precautions or with specific WARNINGS given elsewhere in this manual violates safety standards of design, manufacture, and intended use of the product. Air Monitor assumes no liability for the customer's failure to comply with these requirements. If this product is used in a manner not specified in this manual, the protection provided by this product may be impaired.

The following messages are used in this manual:

WARNING

Messages identified as "Warning" contain information regarding the personal safety of individuals involved in the installation, operation or service of this product.

CAUTION

Messages identified as "Caution" contain information regarding potential damage to the product or other ancillary products.

IMPORTANT NOTE

Messages identified as "Important Note" contain information critical to the proper operation of the product.

TABLE OF CONTENTS

SECTION 1.0 GENERAL INFORMATION	4
1.1 PURPOSE OF THIS MANUAL.....	4
1.2 TYPICAL AIRFLOW MEASUREMENT SYSTEM INSTALLATIONS	4
1.3 STANDARD FEATURES AND SPECIFICATIONS*	4
1.4 MODEL NUMBERING CODIFICATION	5
1.5 CHECKING THAT YOU RECEIVED EVERYTHING.....	5
1.6 SERIAL NUMBER	5
SECTION 2.0 INSTALLATION.....	6
2.1 TRANSMITTER.....	6
2.1.1 Site Selection.....	6
2.1.2 Transmitter Dimensions	7
2.1.3 Transmitter Installation.....	7
2.1.4 Transmitter Wiring Connections.....	8
2.2.4 Airflow Sensor Process Connections.....	10
2.2.5 S.A.P. Process Connections.....	11
SECTION 3.0 OPERATION	13
3.1 START-UP	13
3.2 ENTERING THE PROGRAMMING MENUS	13
SECTION 4.0 MAIN MENU.....	14
4.1 PRODUCT INFORMATION.....	14
4.2 SET PASSWORD	14
4.3 ANALOG OUTPUT TEST.....	14
4.4 ANALOG OUTPUT CONFIGURATION.....	15
4.5 FILTER	15
4.6 SENSOR STATUS	15
SECTION 5.0 MAINTENANCE.....	16
SECTION 6.0 TROUBLESHOOTING.....	16

SECTION 1.0 GENERAL INFORMATION

Thank you for purchasing the DCAS. As our valued customer, Air Monitor's commitment to you is to provide quality service and support while continuing to offer you accurate, reliable products to meet your flow measurement needs.

1.1 PURPOSE OF THIS MANUAL

This manual provides information regarding the installation, operation and maintenance of your differential pressure measurement system. This manual is the basic reference tool for the DCAS transmitter, including its mains power connection and associated signal inputs and outputs. The complete system consists of the transmitter and associated airflow sensors. Please refer to supplemental documents for additional information.

1.2 TYPICAL AIRFLOW MEASUREMENT SYSTEM INSTALLATIONS

Air Monitor's DCAS System accurately measures the differential pressure between the hot and cold aisles in a data center.

1.3 STANDARD FEATURES AND SPECIFICATIONS*

DCAS TRANSMITTER		
PERFORMANCE	SYSTEM ACCURACY	DP pressure of $\pm 0.75\%$ of reading with 40:1 turndown ratio
OPERATING CONDITIONS	AMBIENT TEMPERATURE	-20°F to 180°F (storage) 0°F to 120°F
	FLUID TEMPERATURE	-40°F to 120°F
	HUMIDITY	0 to 99% RH, non-condensing
INPUT POWER	24 VAC	15 VA @ 24 VAC
	24 VDC	10 W @ 24 VDC
I/O SIGNALS	ANALOG OUTPUTS	Two (2) analog outputs, selectable based on configuration
ELECTRONICS ENCLOSURE	AVAILABLE OPTIONS	• Aluminum, NEMA 1
	DISPLAY	3.5" diagonal color graphical FTF LCD, Display resolution to the hundred thousandths
PROGRAMMING	Menu driven user interface via four (4) push buttons	
ELECTRICAL CONNECTIONS	POWER	Removable terminal block for use with 16 to 24 gauge wire
	I/O	Removable terminal block for use with 16 to 24 gauge wire
PROCESS CONNECTIONS	AVAILABLE OPTIONS	<ul style="list-style-type: none"> • 1/8" FNPT, both high and low signal connections • 1/4" compression, both high and low signal connections • 3/16" hose barb, both high and low signal connections
APPROVALS	FCC	Part 15 Subpart B, Class A device

DCAS PRESSURE SENSOR		
FLOW SENSOR DESIGN	S.A.P.	Static Air Probes
MATERIALS OF CONSTRUCTION	316 SS	
OPERATING CONDITIONS	HUMIDITY	0 to 100% RH, condensing
	ENVIRONMENT	Impervious to airborne dirt, debris, and moisture
PROCESS CONNECTIONS	AVAILABLE OPTIONS	<ul style="list-style-type: none"> • 1/8" FNPT, both high and low signal connections • 1/4" compression, both high and low signal connections • 3/16" hose barb, both high and low signal connections

* SPECIFICATIONS subject to change without notice.

1.4 MODEL NUMBERING CODIFICATION

DCAS Transmitter Model Number Coding = DCAS-ABCD

A = Model Configurations

- 1 = Single Channel
- 2 = Dual-Channel

B = Enclosure

- 1 = NEMA 1 aluminum enclosure

C = Feature Set (Based on model configuration)

- 2 = 24V AC/DC power, two (2) analog outputs

D = Process Connection

- 1 = 1/8" FNPT
- 2 = 1/8" FNPT x 1/4" compression
- 3 = 1/8" FNPT x 3/16" hose barb

1.5 CHECKING THAT YOU RECEIVED EVERYTHING

Carefully open the DCAS shipping container(s) and remove all equipment. Inspect equipment for any damage. If damaged, contact Air Monitor and your freight company. Verify that the following items have been shipped:

- (1) DCAS Transmitter
- (1) DCAS Installation and Operation Manual

1.6 SERIAL NUMBER

The serial number of your DCAS transmitter is located outside of the enclosure. The serial number is a unique identifier for your product. Please have it available when contacting Air Monitor for assistance regarding your product.

SECTION 2.0 INSTALLATION

The DCAS should be installed by experienced technicians and others with related knowledge and experience with airflow systems. Air Monitor support personnel are available to assist with technical recommendations and to provide guidance by telephone and/or e-mail. On-site field engineering, installation, and service are also available at an additional cost. The installer should use good trade practices and must adhere to all state and local building codes.

Each DCAS is individually validated against a NIST-traceable reference. If any problems or discrepancies are detected, contact Air Monitor's Customer Service Department at 727-447-6140 prior to proceeding.

2.1 TRANSMITTER

2.1.1 Site Selection

The tubing length chart shown below is important to the accuracy of the DCAS system. Do not exceed the tube lengths.

Nominal/Min Tubing Internal Diameter (in)	Tube Length Total (ft)	SAP/STAT-Probe Max Distance from Transmitter (ft)
1/8 (0.125)	30	15
3/16 (0.1875)	200	100
1/4 (0.25)	500	250
3/8 (0.375)	1000	500

2.1.2 Transmitter Dimensions

NEMA 1 ENCLOSURE

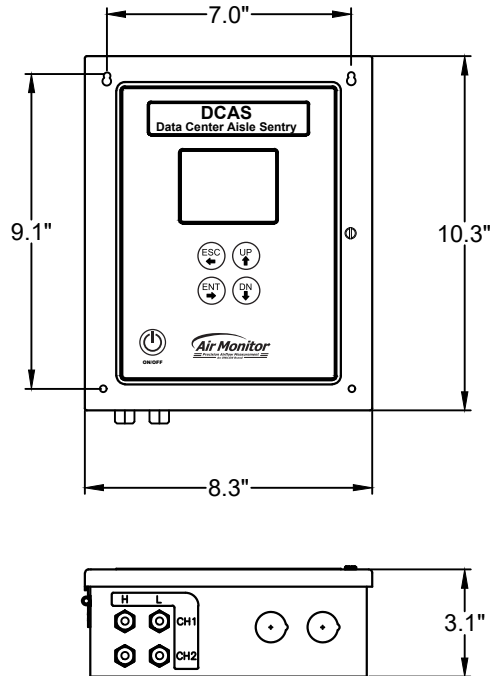

2.1.3 Transmitter Installation

Find an easily accessible location where electrical connections can be made and display readings can be taken from the floor level. The mounting surface must be structurally sound and capable of withstanding a minimum weight of 40lbs (18kg). Use the following screws for mounting.

For NEMA 1 Enclosure:

- (4) Machine screws - #8-32 x 1.5"
- (4) Wood screws - #8 x 1.5"
- (4) Concrete screws - $\frac{3}{16}$ " x 1.5"

2.1.4 Transmitter Wiring Connections

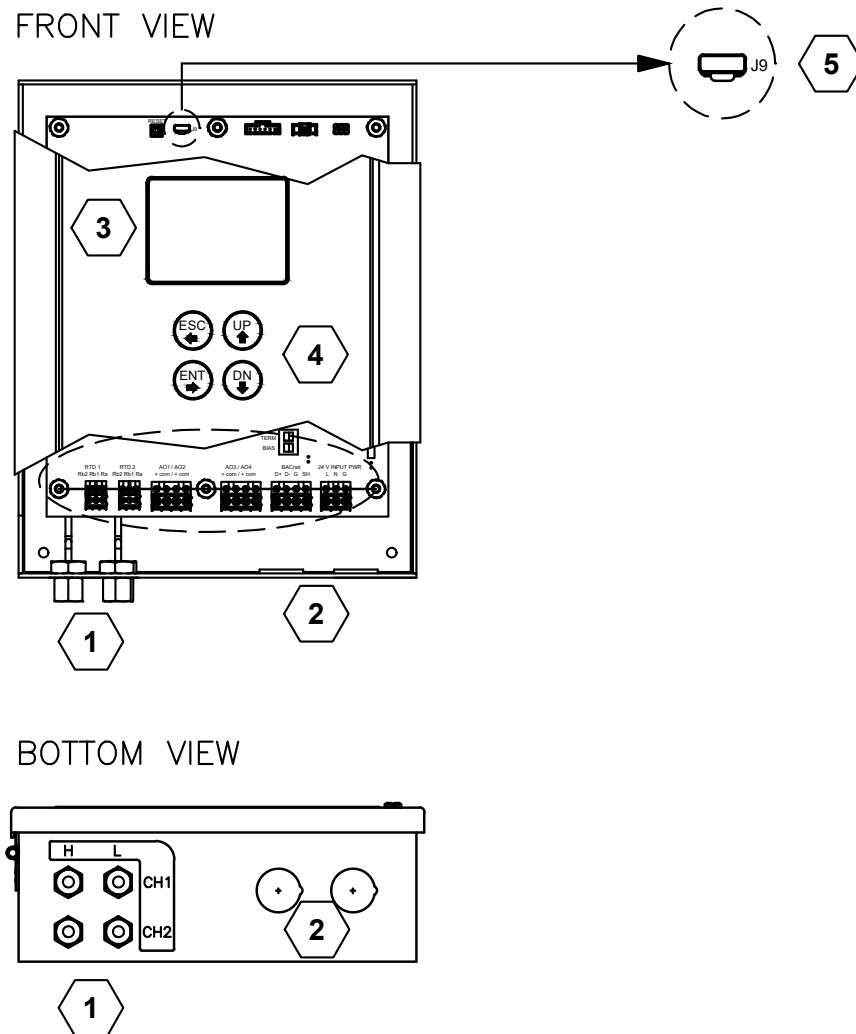

1. 1/8" FNPT connection, two (2) fittings per channel
2. Two (2) 1/2" conduit connection knockouts
3. Graphical LCD for user set-up, commissioning and real time data display
4. User programming and display keys
5. Micro USB connection location

CAUTION

The electrical supply should be relatively clean, free of high frequency noise, large voltage transients, and protected from power surges and brown outs. Avoid installation locations that are in close proximity to strong sources of electrical interference.

2.1.4 Transmitter Wiring Connections (Continued)

A. Power/Signal Connections

Input Power Requirements:

- 24 VAC, 15VA @ 24 VAC
- 24 VDC, 10W @ 24 VDC

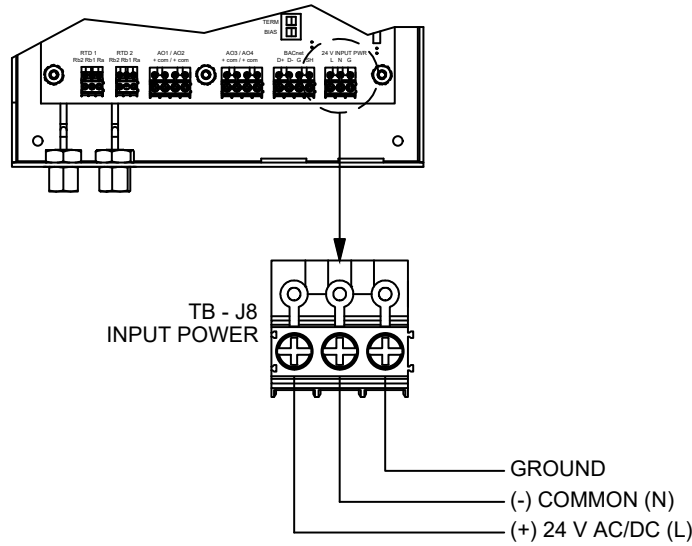

B. Analog Output

Two (2) analog outputs (4-20 mA or 0-10 VDC) are available based on configuration. Refer to section 5.3 ANALOG OUTPUT CONFIGURATION for more information.

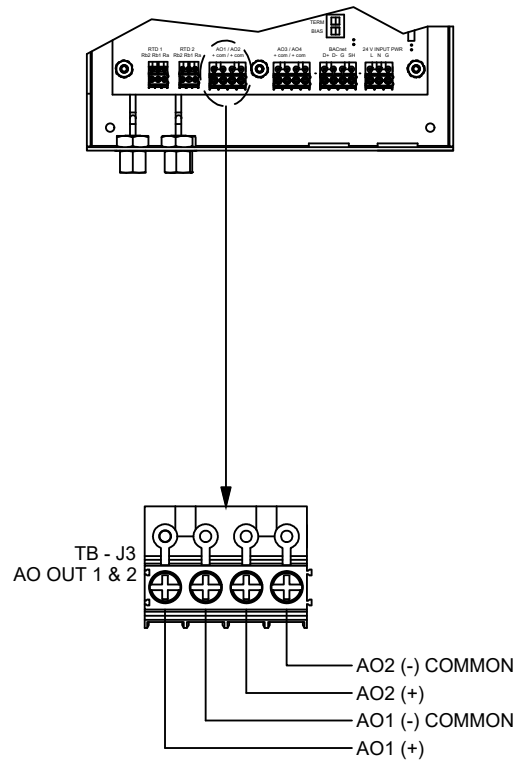

2.2.4 Airflow Sensor Process Connections

Air Monitor recommends that signal tubing between the transmitter enclosure and all sensors be stainless steel or copper of the appropriate size. Use tees or manifolds to combine multiple sensors into single high and low pressure lines running to the transmitter's channel fittings for each channel.

UV resistant, flexible, plastic tubing specifically designed for outdoor use, such as Tygon R-3400 or equivalent, may also be used. Use brass inserts with the plastic tubing as required to ensure a leak free connection.

Refer to section 2.1.1 Site Selection to determine the proper tubing dimension required based on the distance between the transmitter and airflow sensor(s).

CAUTION

Flexible plastic signal tubing used in outdoor applications must be resistant to weathering and the effects of UV exposure. When installing or removing signal tubing from either the enclosure or the sensors, a wrench should be used on the bulkhead nut to prevent it from turning.

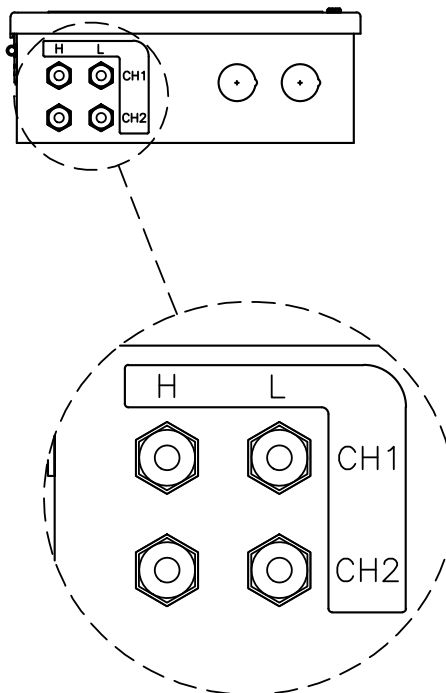

H - High Pressure Port - Connects to the SAP/STAT-probe on cold aisle.
 L - Low Pressure Port - Connects to the SAP/STAT-probe on hot aisle.
 CH1 / CH 2 - Ports associated with each channel.

Signal tubing may be ¼ O.D. if the distance from the S.A.P to the transmitter is 200' or less. Connections to the S.A.P sensors are provided on the next page.

2.2.5 S.A.P. Process Connections

The S.A.P./S and S.A.P./R are furnished with a predrilled mounting plate for bolting or screwing to mounting surfaces, using three fasteners.

S.A.P./S - Surface Mount

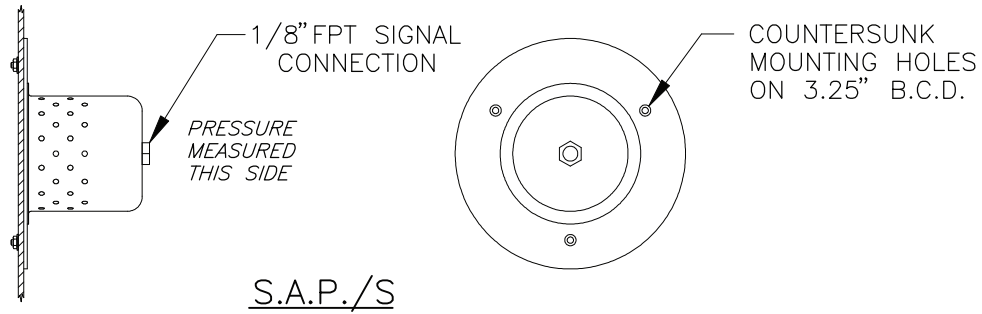

S.A.P./R - Recessed Flush Mount

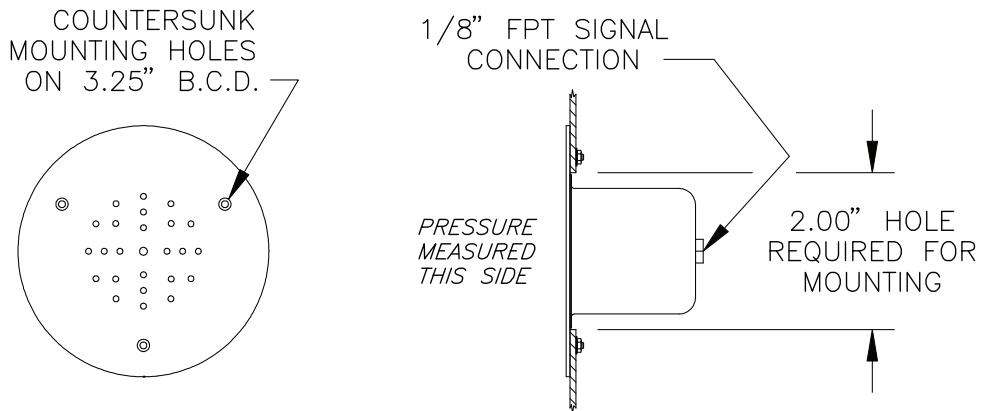

S.A.P./R - External Flush Mount

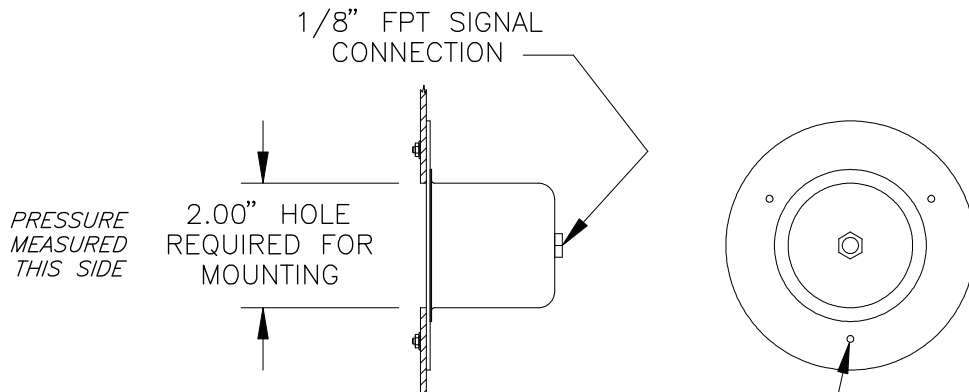

S.A.P./P - Pipe Mount

The S.A.P./P is furnished with a 1/2" FPT signal connection which is also used for mounting.

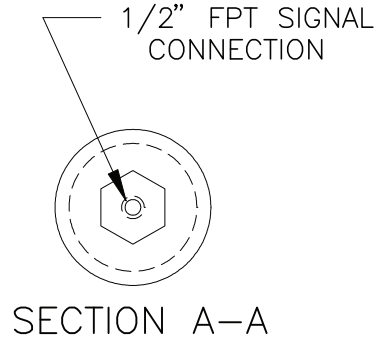
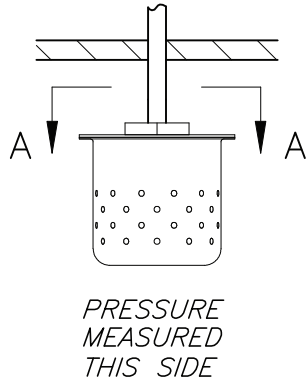

S.A.P./B - Electrical Junction Box Mount

The S.A.P./B is mounted into a standard 2x4 electrical junction box (provided by others).

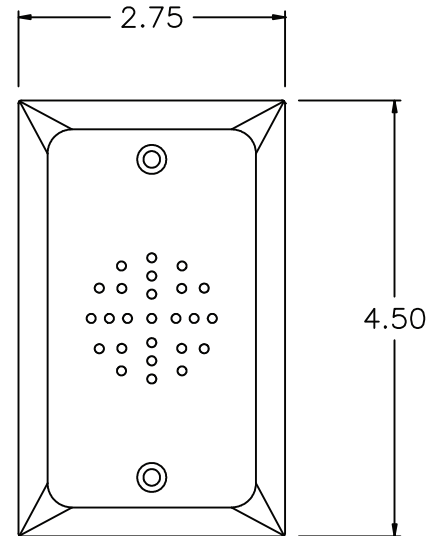
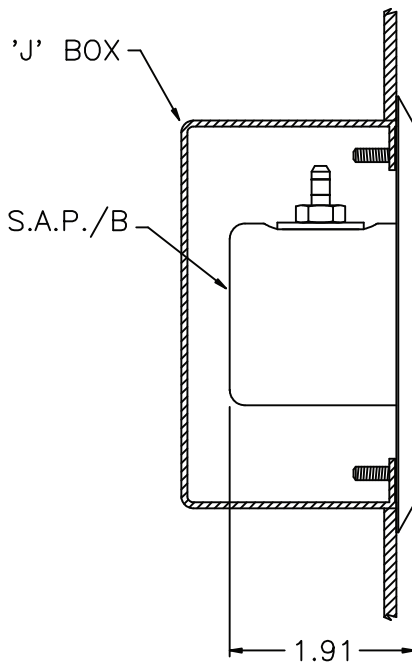

SECTION 3.0 OPERATION

3.1 START-UP

Press the power button located in the lower left corner of the cover. You will see the current version of the software and the company logo displayed at power-up.

There are two displayed channels for the DP signal. Press enter to go to the menu system

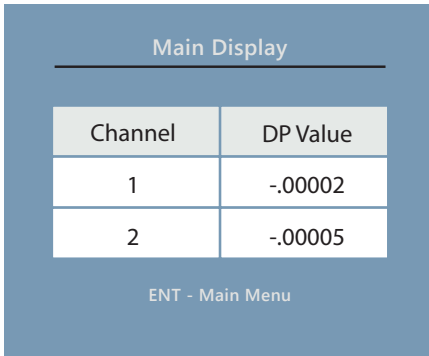

The screenshot shows a blue background with the text 'Main Display' at the top. Below it is a table with two columns: 'Channel' and 'DP Value'. The first row shows '1' and '-.00002'. The second row shows '2' and '-.00005'. At the bottom, it says 'ENT - Main Menu'.

Channel	DP Value
1	-.00002
2	-.00005

ENT - Main Menu

Example of The Main Display

3.2 ENTERING THE PROGRAMMING MENUS

Press ENT at any time to access the programming menus. If the password has been set previously, the following screens will be displayed.

Password Menu

Enter the password and you will be brought to the menu selection screen. Information regarding the password settings can be found in section 4.4 SET PASSWORD.

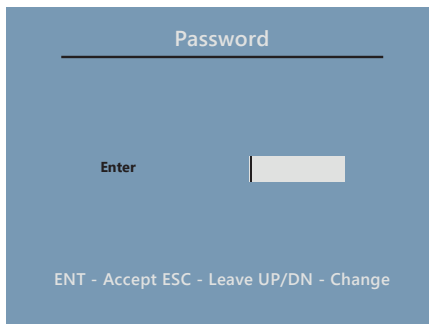

The screenshot shows a blue background with the text 'Password' at the top. Below it is a horizontal line. In the center, there is a small box labeled 'Enter' next to a rectangular input field. At the bottom, it says 'ENT - Accept ESC - Leave UP/DN - Change'.

ENT - Accept ESC - Leave UP/DN - Change

SECTION 4.0 MAIN MENU

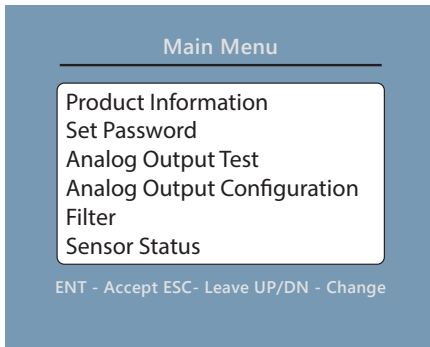

Main menu functions are used to configure transmitter settings common to all configurations.

4.1 PRODUCT INFORMATION

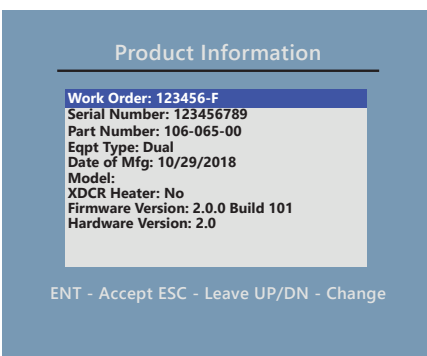

This screen provides detailed information about the transmitter hardware.

4.2 SET PASSWORD

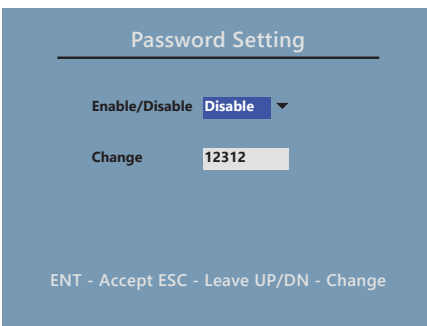

To change the password, enter your new password into the editable field. This overwrites the old password. The password can be up to 8 digits. Alpha and numeric characters are supported. The drop down will allow the user to disable the password if so desired.

4.3 ANALOG OUTPUT TEST

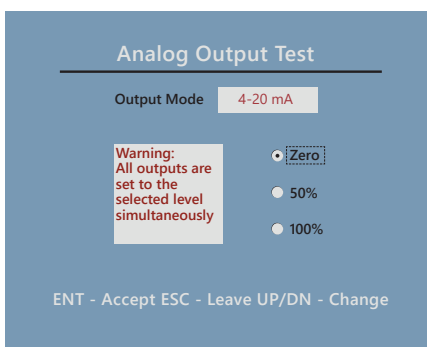

This function allows the user to test the analog outputs. The user can force the outputs to operate at 0%, 50% or 100%.

4.4 ANALOG OUTPUT CONFIGURATION

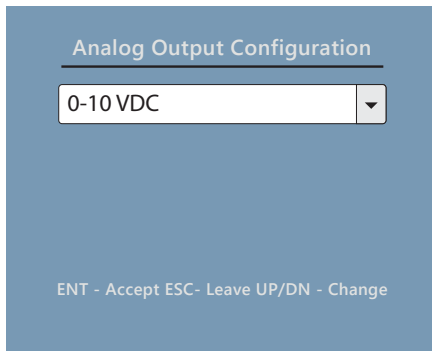

This menu is used to configure the analog outputs. It is highly recommended to use the 4-20mA output rather than the 0-10VDC. This is because the limit of the negative range trends towards 0 volts, so the resolution starts to suffer. The 4-20mA has the 4mA offset which eliminates this issue

Output Type

Use this to configure the output type. The options are 4-20mA, 0-10VDC, or off. Both outputs are set to the same type.

DP Output

0-10V Analog output= (10* DP)+5

4-20ma Analog output= (16* DP)+12

DP	Voltage	mA
-0.5	0	4
-0.4	1	5.6
-0.3	2	7.2
-0.2	3	8.8
-0.1	4	10.4
0	5	12
0.1	6	13.6
0.2	7	15.2
0.3	8	16.8
0.4	9	18.4
0.5	10	20

4.5 FILTER

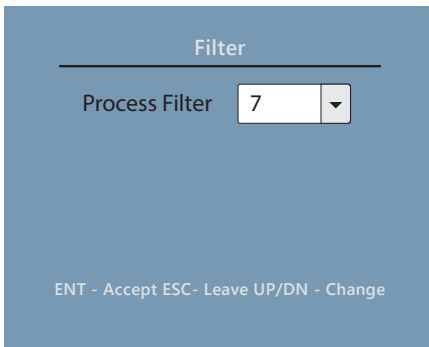

This menu function sets filtering for the analog outputs and the display. It is also used to set the lockdown (low flow cut-off).

Process Filter

The process filter is used to dampen the analog outputs. The settings are from 1-10, where 1 is the softest filter and 10 is the hardest filter. Typically, 2-4 will give a filtered signal which is responsive but provides some dampening.

4.6 SENSOR STATUS

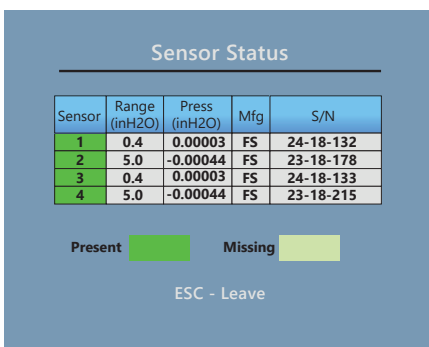

This screen provides real-time operating status for the pressure transducers. The values are the raw unfiltered DP signals from each transducer. The 1 and 3 sensors are the lower range DP and the 2 and 4 are the higher range DP.

SECTION 5.0 MAINTENANCE

The DCAS does not contain any parts that require scheduled maintenance.

The following information is provided, as general guidelines, if you wish to establish an inspection/maintenance program. Start with annual inspections and adjust the frequency as required to meet your needs.

Cleanliness

- Verify condensation or other sources of liquids are not present inside the DCAS.

Mechanical

- Verify signal connections are secure.
- Inspect signal lines for any cracks or leaks.
- Verify mounting hardware is secure.

Electrical

- Inspect wiring to the DCAS for good connections and absence of corrosion.

Calibration Intervals

- Air Monitor does not recommend a specific time interval between re-calibrations. Calibrations should be scheduled to meet the needs of the facility where the DCAS is installed. For example, critical care facilities may wish to schedule annual re-calibrations while commercial/retail buildings may only schedule re-calibrations at 3-5 year intervals.

SECTION 6.0 TROUBLESHOOTING

Problem	Solution
No DP signal detected	Check the lines are clear and correctly hooked up. Check the DP sensor is working (swap with a working channel with the help of an AMC technician)
No visible display	Check for running LED indication to ensure the system is powered Reload the FSU with the help of an AMC technician
DP is lower than expected or erratic	Check for pinched or crimped tubing

