

VOLU-probe/1SS for Round Ducts

WARRANTY

Air Monitor Corporation (hereinafter referred to as "Seller") warrants that at the time of shipment, products sold pursuant to this contract will be free from defects in materials and workmanship, and will conform to the specifications furnished or approved in writing by Seller. No warranty is given that delivered products will conform to catalog sheets, data sheets, and the like, which are subject to change without notice.

Seller will repair or replace, at its option, any products listed under this warranty which is returned freight pre-paid to Seller and within the earlier of one (1) year after start-up or fifteen (15) months after shipment, prove upon test and examination by Seller to be defective within the terms of this warranty. The warranty period for any item repaired or replaced shall be for the time remaining on the warranty period for the original components. Purchaser shall notify Seller in writing of such defect within sixty (60) days of discovery of the defect.

This warranty does not extend to any product sold by Seller which has been the subject of misuse, neglect, accident, damage or malfunction caused by interconnection with equipment manufactured by others, improper installation or storage, or used in violation of instructions furnished by Seller, nor does it extend to any product which has been repaired or altered by persons not expressly approved by Seller. Nor does Seller warrant equipment against normal deterioration due to environment; nor items such as thermocouples, electrodes, and similar items subject to wear or burnout through usage. Adjustments for items or equipment not manufactured by Seller shall be made to the extent of any warranty of the manufacturer or supplier thereof.

Seller shall not be liable for any special or consequential damages or for loss of damage directly or indirectly arising from the use of the products.

The warranty set forth above is in lieu of all other warranties either express or implied and constitutes the full extent of Air Monitor Corporation's liability to the customer, or any other party for breach of warranty. THERE ARE NO EXPRESS WARRANTIES EXCEPT AS SET FORTH HEREIN. THERE ARE NO IMPLIED WARRANTIES OF MERCHANTABILITY OR FITNESS FOR ANY PARTICULAR PURPOSE, WHICH ARE PARTICULARLY DISCLAIMED.

VOLU-probe/1SS for Round Ducts – Installation Procedure

INSPECTION & HANDLING. VOLU-probes should be carefully inspected for damage prior to installation. Report damage to your Freight Department, or contact delivery carrier. Almost any means of handling can be utilized depending on the length and weight of the probes. Probes may be handled while in any position, however it is important not to drop or mishandle the probes such that damage is done to the sensing holes, tubular members, signal connection fittings, end studs, or mounting plates.

ORIENTATION OF PROBES. Using the AIRFLOW directional arrow on the probe mounting flange to determine correct orientation, install VOLU-probes with sensing holes facing airflow

INSTALLING VOLU-probes. To achieve published performance standards, the location of VOLU-probes in ductwork must comply with the *Minimum Requirements for Installation* submittal sheet (Page 7).

VOLU-probe must be mounted so that the sensing holes on the probes are at the centers of equal areas in the duct. If three probes are furnished (as illustrated below), the angle between each probe is 60°. If two probes are furnished, the angle between probes is 90°. The radial dimension (R) between probes is determined by the formula $R=C/2N$ where C is the duct circumference and N the number of probes. VOLU-probe insertion holes (F) and end support holes (G) must be cut in the duct on center lines.

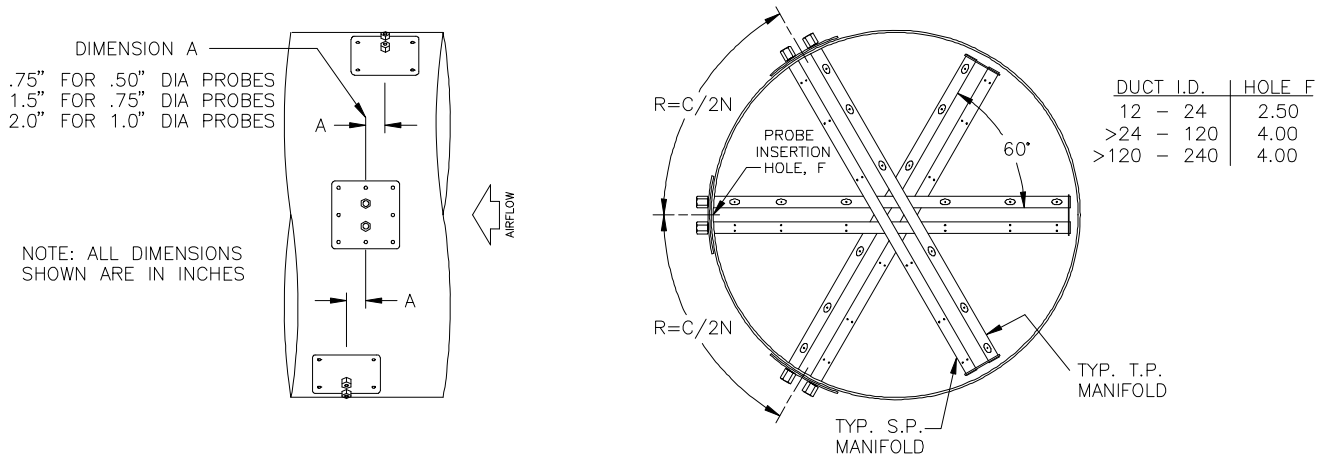

End support conditions for the VOLU-probe/1SS are illustrated below:

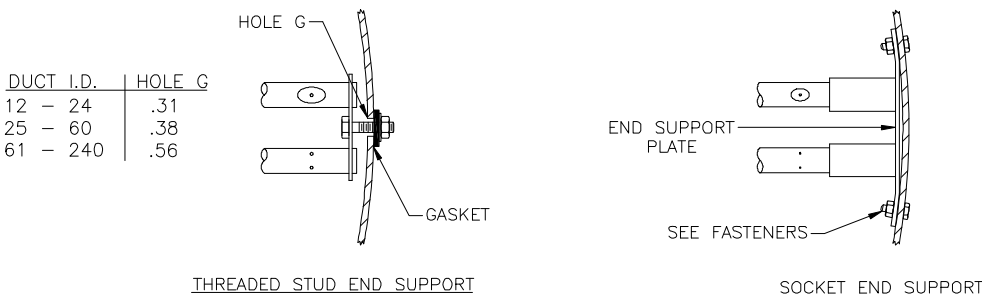

NOTE: This detail does not apply to VOLU-probe/1ss under 18" which does not have end support stud.

VOLU-probe/1SS for Round Ducts – Installation Procedure

FASTENERS. Gasket mounting surfaces should be clean and burr free. VOLU-probe mounting plates are predrilled for 1/4" mounting fasteners. Air Monitor recommends the use of 1/4-20 bolts, nuts, and lock washers (or flat washers and lock nuts). Fasteners should be stainless steel to be compatible with probes.

DIMENSIONAL SPECIFICATIONS.

VOLU-probe/1SS

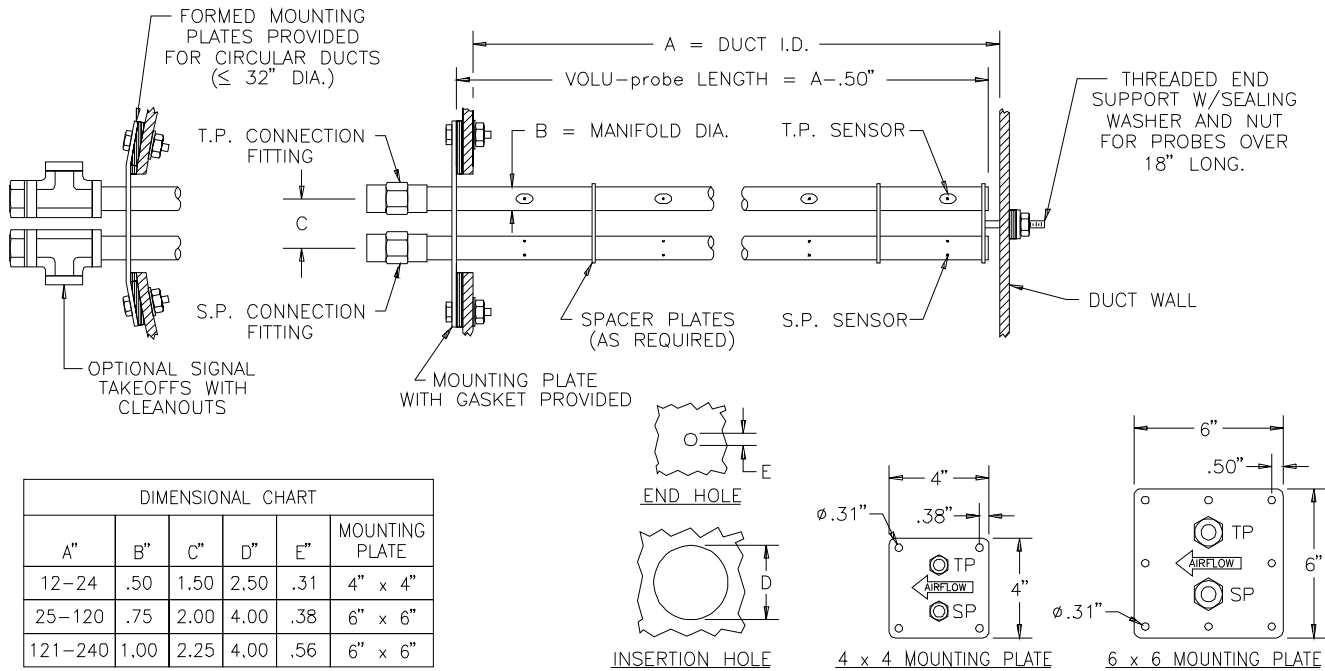

THREAD SEALANT.

Appropriate thread sealant should be selected depending on maximum air temperature. Use of a high temperature pipe sealant at the probe signal fittings is recommended. Teflon tape or equivalent products are not recommended for high temperature applications.

VOLU-probe/1SS for Round Ducts – Installation Procedure

INTERCONNECTING TUBING. Interconnecting tubing and fitting makeup is to be no smaller than the probe connection fitting furnished; either 1/4" or 1/2". Refer to illustrations below for typical tubing configurations.

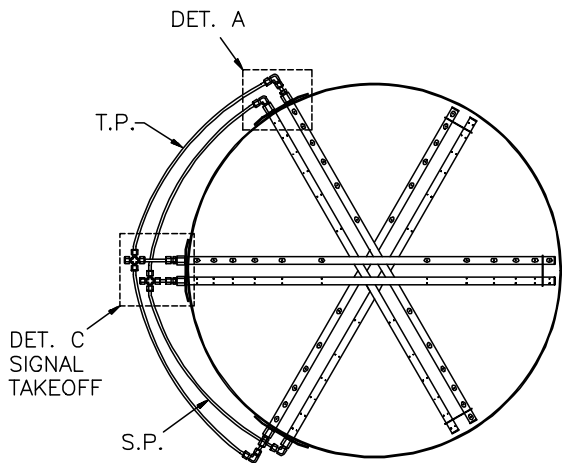

THREE PROBES

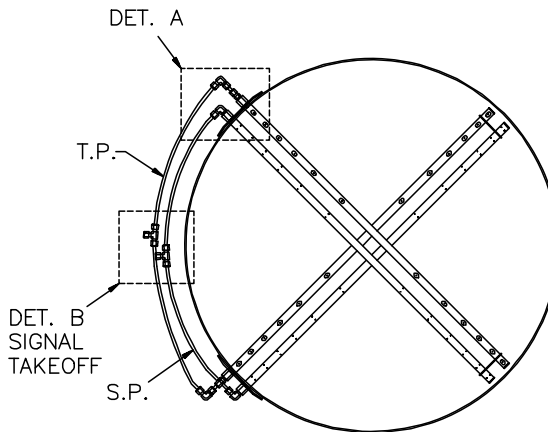

TWO PROBES

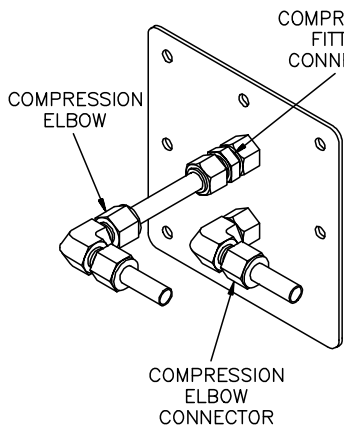

DETAIL A

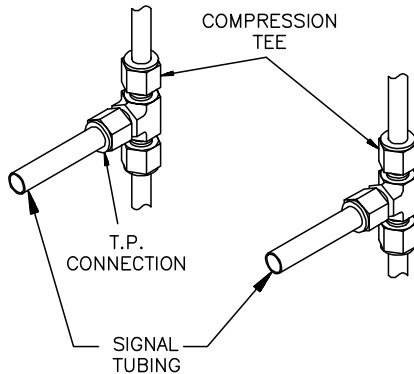

DETAIL B

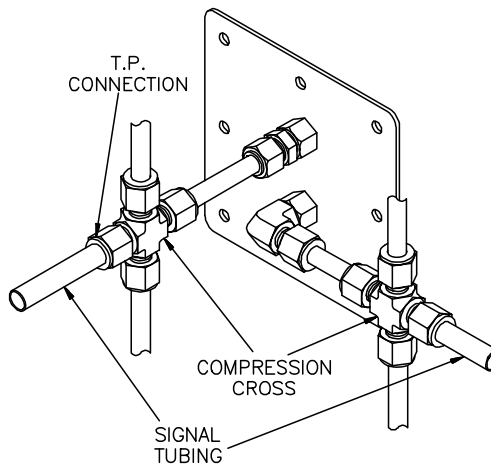

DETAIL C

VOLU-probe/1SS for Round Ducts – Installation Procedure

SIGNAL TUBING. Signal tubing commences at the total and static pressure takeoff connections at the center of the interconnecting tubing array shown in Details B and C. Two signal tubing conditions are possible; tubing with an AUTO-purge panel and tubing without an AUTO-purge or CAMS panel.

If an AUTO-purge panel or CAMS panel is not furnished, signal tubing for total and static pressure take-off connections may be 1/4" O.D. if the distance from the measuring device to the transmitter is 200' or less.

If an AUTO-purge panel is furnished, the total and static pressure signal tubing should be sized per the following Table:

Distance from Takeoff Fittings to Purge Panel	Tubing Size
Under 25 ft.	Under 25 ft.
25 ft. to 50 ft.	25 ft. to 50 ft.

It is not recommended that AUTO-purge panels be located more than 50 feet from takeoff connections. Signal tubing from the purge panel to a transmitter should be sized 1/4" if the distance is 200' or less.

CAUTION: After tubing is completed, signal lines should be leak tested prior to operation. Care must be taken not to overpressurize measuring device.

VOLU-probe/1SS for Round Ducts – Installation Procedure

AIRBORNE CONTAMINANTS:

The levels of air filtration and cleanliness associated with commercial HVAC Systems, whether supply/return/exhaust/outside air, are satisfactory for operation of the VOLU-probe. Industrial applications containing airborne contaminants may require periodic manual or automatic cleaning using compressed air applied to the signal fittings, and/or removal from the duct or stack for physical cleaning.

MINIMUM REQUIREMENTS FOR INSTALLATION:

Note: VOLU-probe locations shown are NOT ideal. They indicate the minimum clearance required from air turbulence producing sources. Wherever possible, the VOLU-probe should be installed where greater runs of straight duct (or clearances) than shown exist.

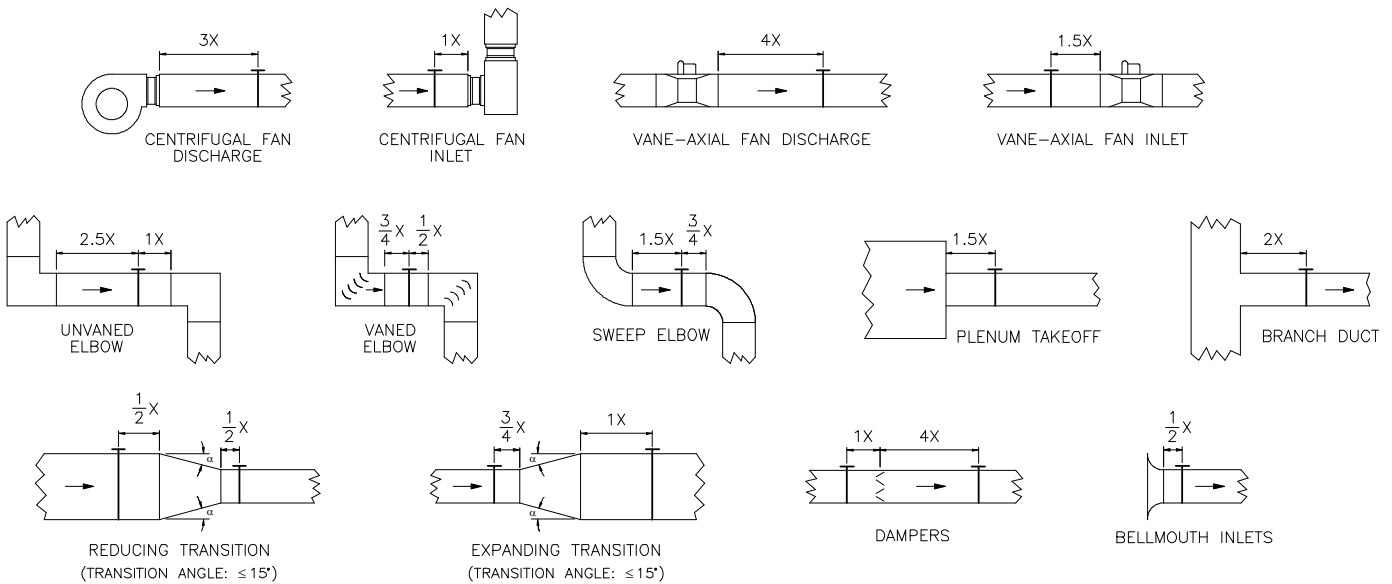

Rectangular Duct: $x = \frac{2(H \times W)}{H + W}$

Circular Duct: $x = \text{Duct Diameter}$

VOLU-probe/1SS for Round Ducts – Installation Procedure

CUSTOMER SERVICE. Air Monitor Corporation provides in-house technical support for all our products

Monday through Friday, 7 am to 5 pm (pst)
Phone: 707-544-2706 or 1-800-AIRFLOW / Fax: 707-526-2825

If after contacting the Customer Service Department it is determined that equipment will require return to Air Monitor Corporation for further repair, a Return Authorization number will be issued. A Confirmation of Return Authorization with shipping instructions will be sent via facsimile or e-mail. Equipment to be returned to Air Monitor should be returned in its original shipping container if possible. If this is not possible, ensure equipment is packaged sufficiently to protect it during shipment.

Caution: All damage occurring during transit is the Customer's responsibility.

List the Return Authorization (R/A) number on the packing list and clearly mark this number on the outside of each shipping container. Costs associated with the return of equipment to Air Monitor Corporation are the customer's responsibility regardless whether the repair/return is under warranty. Once the Customer Service Department determines that the equipment repair is under warranty, the item will be repaired and returned to the customer at no charge. If the equipment is not under warranty, customer will need to approve a repair quote which will be invoiced along with return shipping charges.