

FAN-Evaluator (FAN-E/SS)

Stainless Steel – Commercial

RECTANGULAR CONFIGURATION 90° FLANGE



STANDARD CONSTRUCTION

Casing.	14 ga. type 316 stainless steel, intermittent welded casing sealed with metal caulking.
Flanges.	1-1/2" wide formed flanges.
Air Straightener.	Type 304 stainless steel, bonded construction. 3" deep x 1/2" cell, 2 mil thick.
Total Pressure Header.	Type 316 stainless steel tubing, welded construction.
Static Pressure Probe.	Type 316 stainless steel tubing, welded construction.
Casing Depth.	8" deep.
Connection Fittings.	1/4" stainless steel compression type located on the long dimension.
Identification Label.	Stainless steel, tack welded on (Work Order Number, ID Number).

PERFORMANCE SPECIFICATIONS

Accuracy.	2% when installed per recommended minimum installation requirements.
Outputs.	Individually averaged signals of total and static pressure.
Operating Velocity.	400 - 4000 FPM.
Operating Temperature.	Continuous operation to 200°F.
Directional Sensitivity.	Not measurably affected by directional airflows with pitch and yaw angles up to 30°.
Traverse Pattern.	Log-Tchebycheff rule for rectangular and equal area for circular ducts.
Resistance.	0.3" w.c. @ 4000 FPM.

DIMENSIONAL SPECIFICATIONS

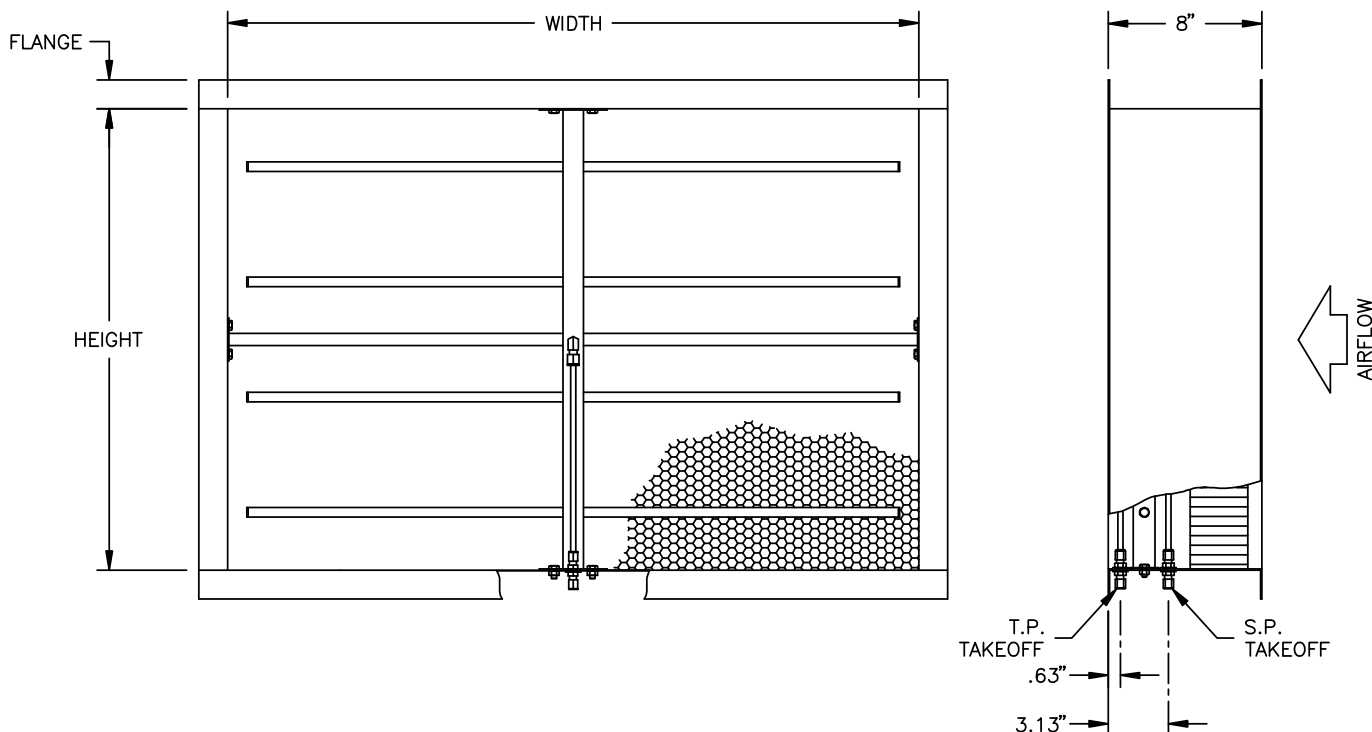

For **OPTIONAL CONSTRUCTION**, refer to Submittal Sheet
"Optional Construction - Stations" – 3.68.0

