



# Air Monitor

Precision Airflow Measurement  
An ONICON Brand

## VOLU-probe/FI

PITOT FAN INLET  
AIRFLOW TRAVERSE  
PROBE

The VOLU-probe/FI uses multiple pitot total and static pressure sensing ports designed specifically for fan airflow measurement.

We believe in our products, so should you.

**1 YEAR NO FAULT WARRANTY**

**3 YEAR MANUFACTURER WARRANTY**



FACTORY CONFIGURED



ON TIME DELIVERY



BEST CUSTOMER SERVICE

• Fan Inlet • Fan Tracking •



## DESCRIPTION

The VOLU-probe/FI Fan Inlet Airflow Traverse Probe consists of a set of two offset mounted traverse probes, each with multiple sensors formulated on a concentric area basis. The VOLU-probe/FI combines the air processing effect of the nozzle-shaped fan inlet bellmouth with its unique Fechheimer Pitot derivative of the multi-point, self-averaging Pitot to accurately measure inlet velocity pressure (and calculable air volume) for most types of fans.

The VOLU-probe/FI probes are mounted directly in the inlet bellmouth at the throat (minimum diameter). When mounted per factory recommendations, the measurement capability of the VOLU-probe/FI is not impaired by inlet screens, fan shafts, drive pulleys, guards, adjustable blade pitch (vane-axial fans), etc., downstream of the probe location.

## FEATURES

**Extruded Aluminum, Anodized Construction.** The standard VOLU-prob/FI is constructed of anodized extruded aluminum. The exterior surface of the probe has an anodized finish which prevents the forming of aluminum oxide, and inhibits the effect of many corrosive atmospheres. VOLU-probe/FI's for fan inlets smaller than 20" in diameter are constructed using copper tubing. The VOLU-probe/FI is also available in Type 316 stainless steel, PVC, Kynar, and other materials of construction.

**Performs Equal-Weighted Averaging of Flow Signals.** The VOLU-probe/FI instantaneously averages, on an equal-weighted basis, all the pressures sensed at the multiple total and static pressure sensors along the length of its probes, in the respective averaging manifolds provided, producing final averaged total and static pressure values which are transmitted to the probe's external signal fittings.

**Measurement Accuracy.** When correctly installed per Air Monitor's recommended methods and positions, the VOLU-probe/FI fan inlet probe will produce assured measuring accuracy  $\pm 3\%$  of the reading over a high range of 2,000-12,000 FPM without impacting fan performance or contributing to fan generated noise.

**No Sensor Protrusions.** The VOLU-probe/FI's total and static pressure sensors are all contained within the confines of the external surface of the probe. There are no protruding sensors to be bent, broken, or otherwise damaged during installation or with continuous fan operation.

**No Correction of Calibration Factors.** The VOLU-probe/FI produces velocity pressure (total and static pressure) signals that are identical in basic magnitude to those obtained with the use of a Pitot tube or airflow measuring station and, therefore, do not require the application of any calibration factors.

**BMS/BAS Communication.** Pairing the VOLU-probe/FI with the VELTRON III provides Display, BACnet, MODBUS, and Analog outputs for  $\pm 3\%$  of the reading accuracy. The VELTRON III can measure two fan walls or two individual fans on one transmitter.

**HOW IT WORKS**

The VOLU-probe/FI operates on the principle of a multi-point, self-averaging Pitot tube to measure the total pressure and static pressure components of airflow. Total pressure sensing ports, with chamfered entrances to eliminate air direction effects, are located on the leading surface of the VOLU-probe/FI to sense to the impact pressure ( $P_t$ ) of the approaching airstream (see Figure 1). Pairs of static pressure sensing ports, positioned at the ideal angle on opposing surfaces of the probe, minimize the error inducing effect of directionalized airflow. As the flow direction veers from the normal, one static sensor is exposed to a higher pressure ( $P_s + \text{part of } P_t$ ), whereas the other static sensor experiences a lower pressure ( $P_s - \text{part of } P_t$ ) of the same magnitude, thereby balancing out the undesired effect of total pressure ( $P_t$ ). It is this unique design of offset static pressure and chamfered total pressure sensors (see Figure 2) that makes the VOLU-probe/FI insensitive to approaching, multi-directional, rotating airflow with yaw and pitch up to 30° from straight flow, thereby assuring the accurate measurement of the sensed airflow rate without the presence of an airflow straightener upstream.

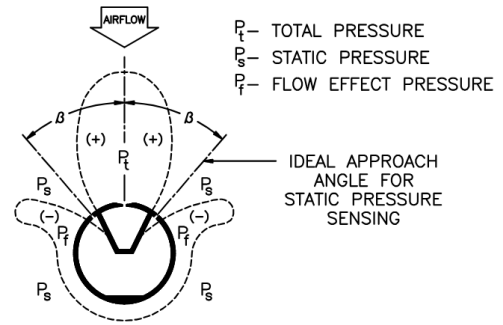

**Figure 1**

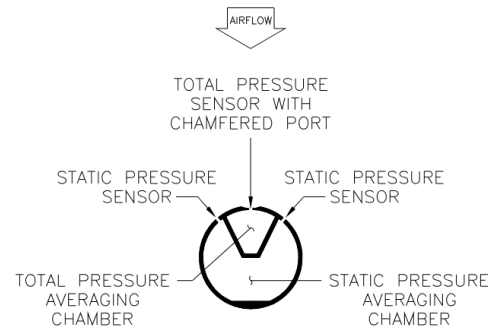

**Figure 2**

**STANDARD FAN INLET CONFIGURATIONS**

**CENTRIFUGAL FANS**

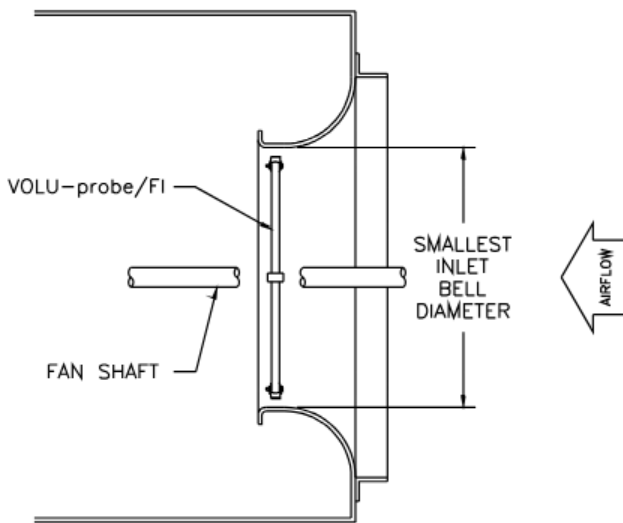

NOTE: Where double width, double inlet centrifugal fans are utilized in HVAC system design, a set of the offset-mounted VOLU-probe/FI fan inlet airflow traverse probes must be mounted in each of the two fan inlets and interconnected via signal tubing.

**VANE-AXIAL FANS**

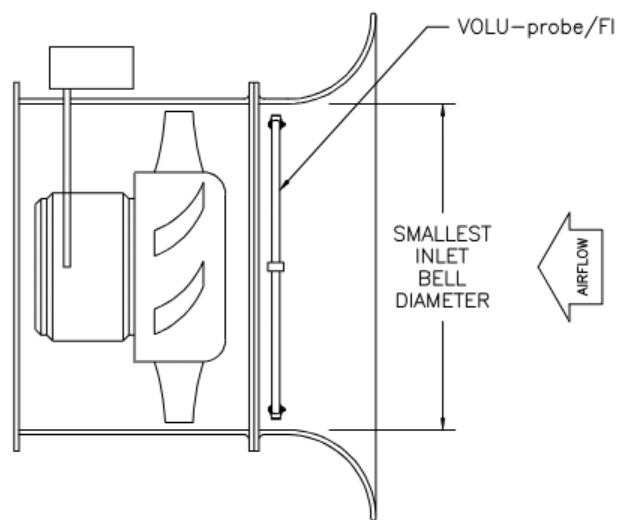

NOTE: When vane-axial fans are installed in a ducted configuration on the inlet side, the application may require the use of the VOLU-probe/FI designed for ducted airflow. Contact factory for recommendation.

**DIMENSIONAL AND CONSTRUCTION INFORMATION**

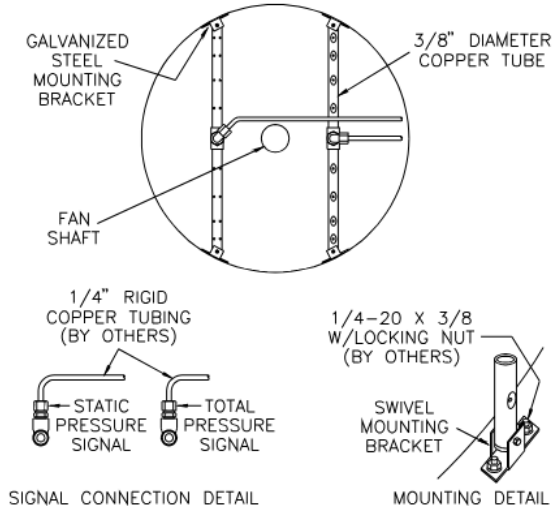

**FOR INLETS LESS THAN 20" IN DIAMETER**

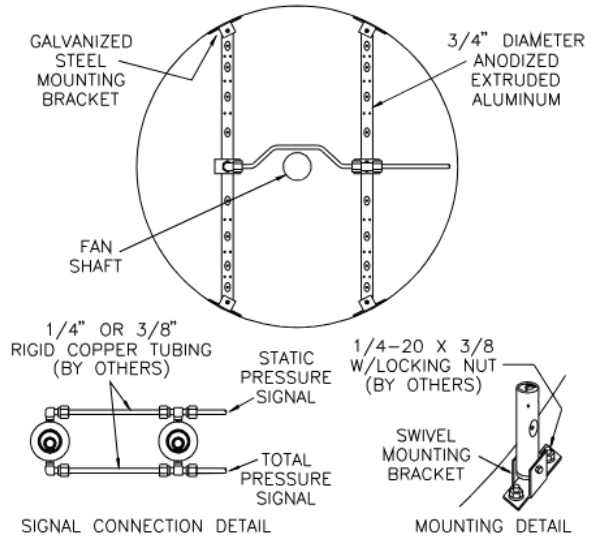

**FOR INLETS 20" IN DIAMETER OR LARGER**

**APPLICATION AND SIZING**

To apply the VOLU-probe/FI to fan inlets, the following determinations must be made:

1. The VOLU-probe/FI was designed specifically to mount in the minimum diameter point of the fan inlet bell. Mounting at any other location on the inlet bell will produce a repeatable flow signal that may require a field determined factor to correlate to actual fan output.
2. When ordering, provide the minimum diameter (mounting location) of the fan inlet bellmouth. DO NOT provide fan wheel diameter.
3. When ordering, advise the presence and size of any fan shaft in the inlet.
4. Due to variations in fan design and construction, contact the factory regarding application suitability for installation on fans having inlet vanes or dampers, extra large motor shafts, motor mountings in the fan inlet, and any auxiliary equipment that could interfere with probe mounting and connecting tubing.

## APPROVED FAN INLET INSTALLATIONS

It is recognized that any obstruction, depending on the obstruction cross-sectional area versus the fan inlet area ratio, has the potential to affect fan output performance. This factor should be given consideration during the process of fan size selection.

Air Monitor's VOLU-probe/FI has been specifically engineered with three different size inlet probes to minimize any impact on operating performance for fans of the types shown below.

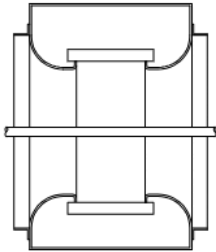

**CENTRIFUGAL FANS**

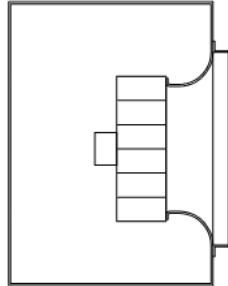

**PLUG FAN**

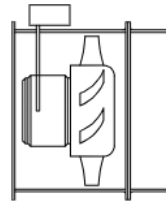

**DUCTED VANE AXIAL**

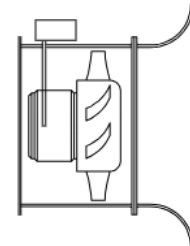

**VANE AXIAL  
WITH BELL MOUTH**

Note: On fans with ducted inlets, the VOLU-probe/FI must still be mounted in the fan inlet bell; otherwise refer to the VOLU-probe brochure for ducted airflow probes.

## SPECIFICATIONS

<b>VOLU-probe/FI</b>	
ACCURACY	±3% of actual airflow over a fan operation range of 6 to 1 fan turndown ratio
OUTPUTS	The probes shall be capable of producing steady, non-pulsating signals of standard total and static pressure, without need for flow corrections or factors.
OPERATING VELOCITY	2,000-12,000 FPM
OPERATING TEMPERATURE	Continuous operation to 200°F
NUMBER OF PROBES	2 probes for SWSI and 4 probes for DWDI
NUMBER OF SENSING PORTS	4 to 12 ports per probe
SENSING PATTERN	Concentric area circles
PROBE MATERIAL	Copper tube <20" or anodized aluminum >20". SS option available.
MOUNTING BRACKETS	Galvanized Steel. SS option available.
CONNECTION FITTINGS	1/4" brass compression 1/4" SS compression or 1/8" SS FPT for SS probes.

