

Application Optimizer

SPOTLIGHT

Process Heaters

How well have you optimized your process?

1



FT4A

Fuel Gas to Burner

"Ensure complete combustions with minimal emissions"

APPLICATION CHALLENGES

- Variety of Fuel compositions
- Low flow, low pressure
- Mass flow desired

IDEAL PRODUCTS

- Fox Thermal FT1/FT4A/FT4X
 - In-situ Calibration Validation w/ cert.
 - No temp or pressure compensation needed
 - Gas selection menu - (multiple fuels)

OTHER PRODUCT OPTIONS

- Retractor assembly
 - online maintenance
- Inline or insertion installation

WITH MULTIVARIABLE TRANSMITTER 2 3

- MASS-tron II Transmitter
 - best for standard applications
- VELTRON DPT-Plus
 - best for Class 1 Div 1

OTHER PRODUCT OPTIONS 2 3

- AUTO-purge III
 - best for dirty service
- Custom material selections:
 - Hastelloy, corrosion-resistant
 - Inconel, high temperatures
- Multipoint temp probe

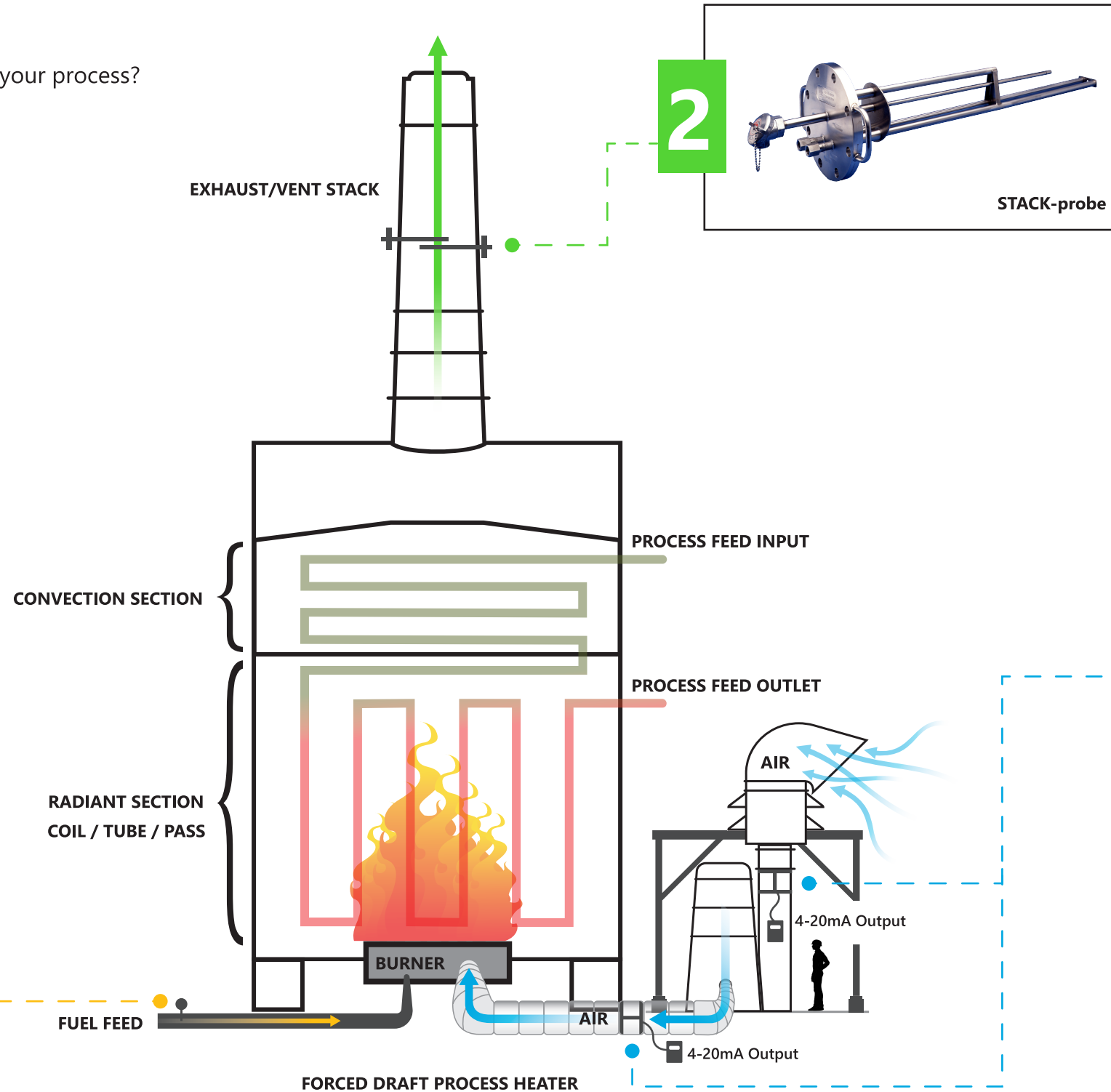

2

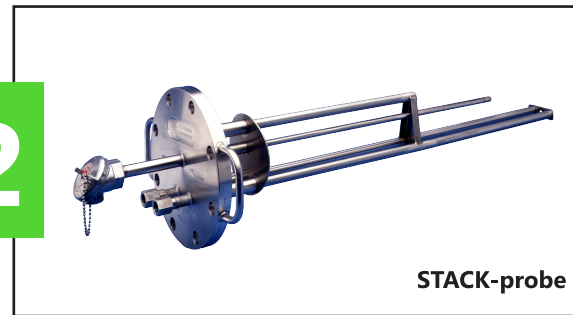

STACK-probe

Exhaust to Atmosphere

"Stay in compliance with EPA and other air quality regulations"

APPLICATION CHALLENGES

- Dirty exhaust gas potential
- Reporting typically required
- Corrosive potential
- High temperature

IDEAL PRODUCTS

- STACK-probe
 - Multipoint averaging probe
 - Closely matches the EPA RATA test

WITH TRANSMITTER

- MASS-tron II/CEM (continuous emissions monitoring)
 - AUTO-zero, eliminate transmitter zero error
 - AUTO-cal, measure transmitter zero & span drift
 - Temperature and absolute pressure compensated mass flow output

3

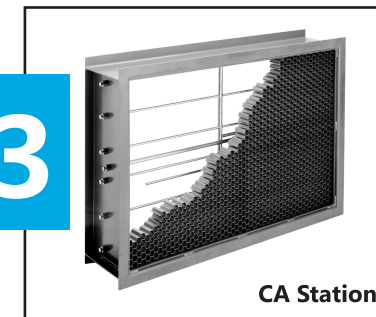

CA Station

Air Inlet

"Optimize combustion and eliminate false trips"

APPLICATION CHALLENGES

- Limited straight run available
- High-turndown, low velocity
- Particulate-laden gas stream

IDEAL PRODUCTS

- CA Station Combustion Airflow Measurement System
 - best for limited straight runs
- VOLU-probe/SS Airflow Traverse Probe
 - best for moderate straight run

Schedule time with one of our experts.

[CLICK HERE!](#)



amcsales@airmonitor.com



sales@foxthermal.com