

Installation, Operation, and Maintenance Manual

AUTO-purge III Panel

Installation, Operation & Maintenance

**Air Monitor Corporation provides complete
technical support between the hours of
7 a.m. and 5 p.m. PST, M-F**

**Contact our Service Department
Toll Free: 1-800-AIRFLOW**

or fax us at 1-707-526-2825



TABLE OF CONTENTS

INSTRUMENT WARRANTY i

SECTION 1 – GENERAL INFORMATION

1.1 DESCRIPTION 1
 1.2 SEQUENCE OF OPERATION 1

SECTION 2 – FEATURES

2.1 CONSTRUCTION 2
 2.2 MULTIPLE OPERATING POWER OPTIONS 2
 2.3 ENCLOSURE HEATING 2

SECTION 3 – INSTALLATION

3.1 RECEIVING AND INSPECTION 3
 3.2 LOCATION 3
 3.3 MOUNTING 4
 3.4 PROCESS CONNECTIONS 4-5
 3.5 ACCUMULATOR TANK 5
 3.6 ELECTRICAL CONNECTIONS 6

SECTION 4 – SET-UP

4.1 VERIFICATION OF PURGE PRESSURE 7

SECTION 5 – OPERATION 8

SECTION 6 – VERIFICATION OF PURGE PERFORMANCE 9

SECTION 7 – MAINTENANCE

7.1 INSPECTION 10

SECTION 8 – TROUBLE SHOOTING 11

SECTION 9 – CUSTOMER SERVICE

9.1 CUSTOMER SERVICE 12
 9.2 REPAIRS/RETURNS 12
 9.3 WARRANTY REPAIR/RETURN 12
 9.4 NON-WARRANTY REPAIRS/RETURNS 12
 9.5 FIELD SERVICE 12

INSTRUMENT WARRANTY

Air Monitor Corporation (hereinafter referred to as "Seller") warrants that at the time of shipment, products sold pursuant to this contract will be free from defects in materials and workmanship, and will conform to the specifications furnished or approved in writing by Seller. No warranty is given that delivered products will conform to catalog sheets, data sheets, and the like, which are subject to change without notice.

Seller will repair or replace, at its option, any products listed under this warranty which is returned freight prepaid to Seller within two (2) years after start-up or twenty-seven (27) months after shipment, prove upon test and examination by Seller to be defective within the terms of this warranty. The warranty period for any item repaired or replaced shall be for the time remaining on the warranty period of the original components. Purchaser shall notify Seller in writing of such defect within sixty (60) days of discovery of the defect.

This warranty does not extend to any product sold by Seller which has been the subject of misuse, neglect, accident, damage or malfunction caused by interconnection with equipment manufactured by others, improper installation or storage, or used in violation of

instructions furnished by Seller, nor does it extend to any product which has been repaired or altered by persons not expressly approved by Seller. Nor does Seller warrant equipment against normal deterioration due to environment; nor items such as lamps, glass, and similar items subject to wear or burnout through usage. Adjustments for items or equipment not manufactured by Seller shall be made to the extent of any warranty of the manufacturer or supplier thereof.

Seller shall not be liable for any special or consequential damages or for loss of damage, directly or indirectly arising from the use of the products.

The warranty set forth above is in lieu of all other warranties either express or implied and constitutes the full extent of Air Monitor Corporation's liability to the customer, or any other party for breach of warranty.

THERE ARE NO EXPRESS WARRANTIES EXCEPT AS SET FORTH HEREIN AND THERE ARE NO IMPLIED WARRANTIES OF MERCHANTABILITY OF FITNESS FOR ANY PARTICULAR PURPOSE, WHICH ARE PARTICULARLY DISCLAIMED.

NOTICE OF PROPRIETARY RIGHTS

This document contains confidential technical data, including trade secrets and proprietary information which are the sole property of Air Monitor Corporation. The use of said data is solely limited to use as specified herein. Any other use is strictly prohibited without the prior written consent of Air Monitor Corporation.

1 – GENERAL INFORMATION

1.1 – DESCRIPTION

Air Monitor's AUTO-purge III is designed for applications where the presence of airborne particulate might impair the measurement accuracy of Air Monitor's Combustion Air Station or VOLU-probe/SS array. When initiated by an Air Monitor "smart" flow transmitter (such as the VELTRON II, VEL-trol II, or MASS-tron II) the AUTO-purge III activates a combination of fail-safe valves that route high pressure/high volume plant air to the flow measuring device for a short duration, while simultaneously isolating the flow transmitter from overpressurization. This periodic purging assists in maintaining the total and static sensing ports of the flow measuring devices in a clear, unobstructed condition.

1.2 – SEQUENCE OF OPERATION

Upon initiation of an AUTO-purge cycle (via external command), solenoid valves on SV-1A and SV-1B will be energized, allowing pilot air (AS-1) to shuttle SV-1A and SV-1B, isolating the transmitter from the signal lines.

After three seconds, SV-2 will be energized, allowing high pressure purge air (AS-2) to flow to the total and static sensing ports of the flow measuring devices.

When the programming purge duration is complete, SV-2 is de-energized removing purge air. A programmable after purge duration allows for residual high pressure to bleed off before SV-1A and SV-1B shuttle back to re-connect the transmitter to the signal lines.

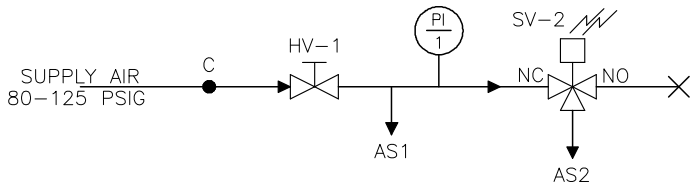

SUPPLY AIR SCHEMATIC

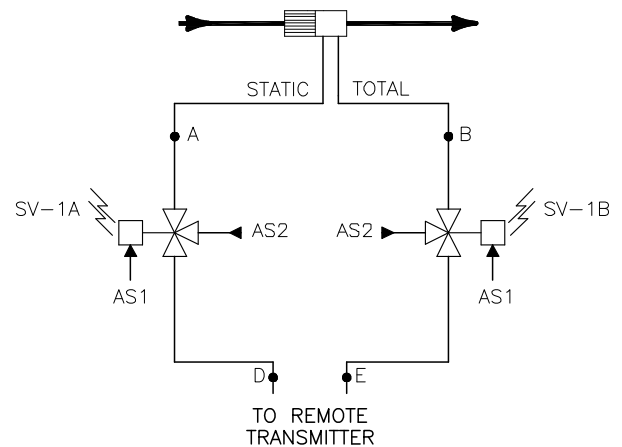

STATIC & TOTAL PRESSURE SCHEMATIC

2 – FEATURES

2.1 – CONSTRUCTION

Brass and Copper.

- All wetted tubing, fittings, and valves constructed of copper and/or brass.
- Enclosure is NEMA 4 painted steel.*
- External connection fittings are stainless steel FPT.

or

Stainless Steel.

- All wetted tubing, fittings, and valves are constructed of 316 stainless steel.
- Enclosure is NEMA 4 painted steel.*
- External connection fittings are stainless steel FPT.

*Stainless steel or fiberglass NEMA 4X enclosure optionally available.

2.2 – MULTIPLE OPERATING POWER OPTIONS

The AUTO-purge III panel is available from the Factory in 24VAC, 24VDC, or 120VAC operating power.

Power requirements:

- 24VAC. 74VA (in rush), 62VA (continuous)
- 24VDC. 28W
- 120VAC. 77VA (in rush), 65VA (continuous)

2.3 – ENCLOSURE HEATING

An optional enclosure heater is available for the AUTO-purge III panel. Requires 120VAC (3.2 amps) power.

3 – INSTALLATION

3.1 – RECEIVING AND INSPECTION

- Carefully remove the AUTO-purge III Panel from its shipping container and inspect for any damage. If damaged, contact freight company.
- Verify the AUTO-purge III Panel is configured according to your order. If not, contact Air Monitor's Customer Service Department at 1-800-AIRFLOW for further guidance.

3.2 – LOCATION

- The AUTO-purge III Panel is housed in a NEMA 4 enclosure which is suitable for outdoor locations.
- The ambient temperature of the selected location must be between 32° – 120°F, unless an appropriate means of heating or cooling are included.
- The selected mounting location should be rigid and free of vibration.
- The AUTO-purge III Panel should be mounted as close as possible to its associated flow measuring station or probes. In no case should the distance be greater than 50 feet. See Section 3.4 for appropriate line sizes.

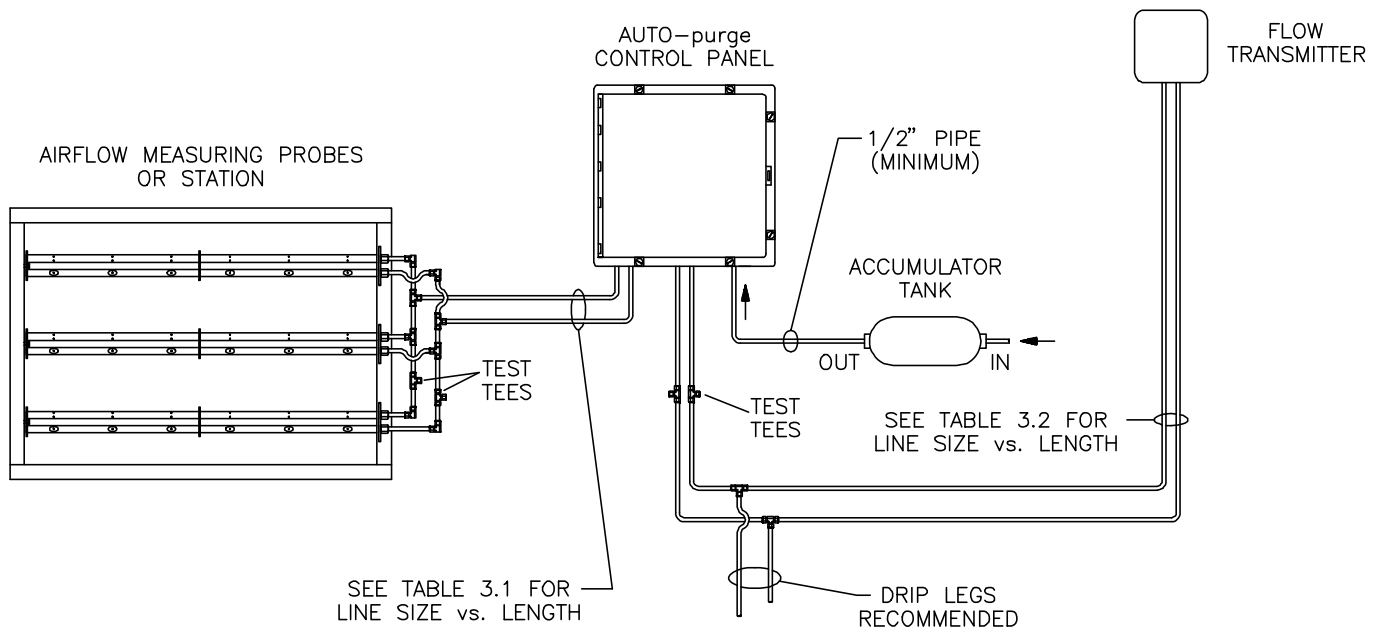

Figure 3.1

3.3 – MOUNTING

- The AUTO-purge III Panel can be mounted in any position provided it is secured by all four mounting tabs.
- Secure the AUTO-purge III Panel utilizing appropriate hardware.

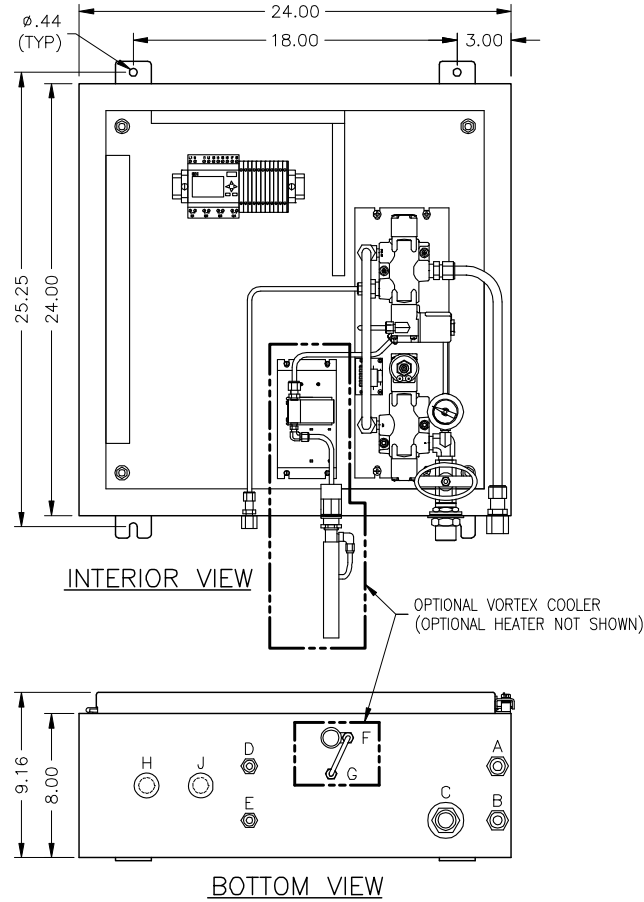

Figure 3.2

3.4 – PROCESS CONNECTIONS

CONNECTION CODE

A. STATIC PRESSURE (LO) SIGNAL FROM FLOW ELEMENT	1/2" (F)NPT
B. TOTAL PRESSURE (HI) SIGNAL FROM FLOW ELEMENT	1/2" (F)NPT
C. SUPPLY AIR 80 – 125 PSIG	1/2" (F)NPT
D. STATIC PRESSURE TO TRANSMITTER	1/4" (F)NPT
E. TOTAL PRESSURE TO TRANSMITTER	1/4" (F)NPT
F. VORTEX COOLER MOUNTING HOLE	N/A
G. VORTEX COOLER AIR SUPPLY	N/A
H. ELECTRICAL CONNECTION POWER WIRING	1/2" CONDUIT SEAL
J. ELECTRICAL CONNECTION SIGNAL WIRING	1/2" CONDUIT SEAL

- Figure 3.2 depicts the various bulkhead connections located on the bottom of the AUTO-purge III Panel.
- To bulkheads A, B, D, and E install appropriate connection fittings according to Table 3.1 and 3.2.
- To bulkhead C install appropriate connection fitting for 1/2" or larger pipe.

CAUTION

- Selected connection fittings must be compatible with the bulkhead fittings on the AUTO-purge III Panel.
- Connection fittings must be installed using appropriate thread lubricant/sealant.
- When installing or removing connection fittings, a wrench should be used on the bulkhead fitting to prevent turning.

3.4 – PROCESS CONNECTIONS (con't)

Static and Total Pressure from Flow Station/Probe (Connection Code A and B). For tubing sizes versus length, see Table 3.1 below:

Distance from Flow Measuring Station or Probe to AUTO-purge III	Minimum Tube Size
Under 25 feet	1/2" O.D.*
25 to 50 feet	3/4" O.D.*
Greater than 50 feet	1.0" O.D.*

*Wall thickness no greater than 0.065".

Table 3.1

NOTE: Recommended Tubing Wall Thickness: .035" wall tubing is suitable for compression fittings. If socket weld fittings are substituted, increase wall thickness to .065".

At or near the Flow Station/Probe, test tees should be installed (see Figure 3.1). On multiple probe assemblies, these tees should be located in the interconnecting tubing, and as far away as possible from the incoming signal transport lines. This test tee will be utilized in Section 4.

Static and Total Pressure from AUTO-purge Panel to Remote Flow Transmitter (Connection Code D and E). For tubing sizes versus length, see Table 3.2 below:

Distance from Purge Panel to Flow Transmitter	Minimum Tube Size
Under 50 feet	1/4"
50 to 200 feet	3/8"
Greater than 200 feet	1/2"

Table 3.2

Drip legs (see Figure 3.1) should be installed to preclude the migration of humidity/water into the flow transmitter. The drip legs should be installed at the lowest point in the signal lines.

Supply Air (Connection Code C). Air should be connected with a minimum of 1/2" Schedule 40 pipe. Supply air must be supplied at 80 to 125 psig at 100 CFM, oil and dirt free.

Electrical Connections (Connections Code H and J). See Section 3.6.

3.5 – ACCUMULATOR TANK

For the optimum performance of the AUTO-purge III system, it is recommended that an accumulator tank be used as a reservoir for purge air (see Figure 3.1). Table 3.3 lists recommended tank sizes.

Station or Probe Size	Accumulator Tank Size
All CA Stations	120 Gallons
VOLU-probes having combined length less than 10 feet	80 Gallons
VOLU-probes having combined length greater than 10 feet	120 Gallon

Table 3.3

The accumulator tank should be furnished with pressure regulator, coalescing filter, check valve, and pressure relief valve.

3.6 – ELECTRICAL CONNECTIONS

It is recommended that wiring be 14 to 22 AWG.

AUTO-purge Start/Stop Command. Customer is to provide powered contact closure of correct voltage for duration of purge cycle. This contact closure is typically provided by Air Monitor's VELTRON II, VEL-trol II, or MASS-tron II as these "smart" transmitters allow AUTO-purge programming. See Figure 3.3 below for wiring details.

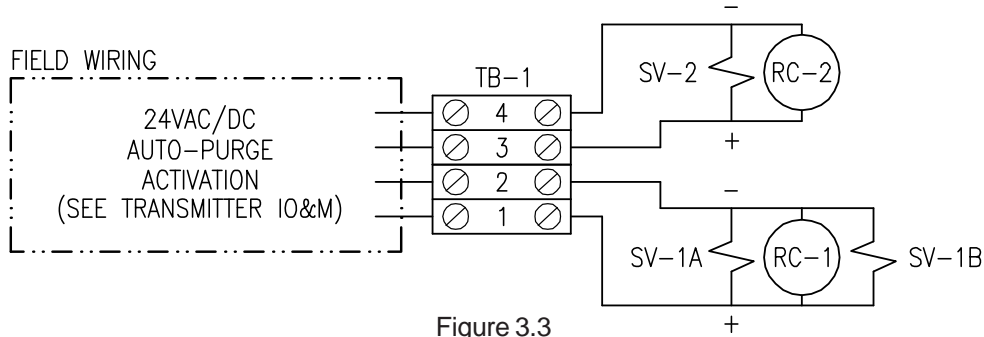
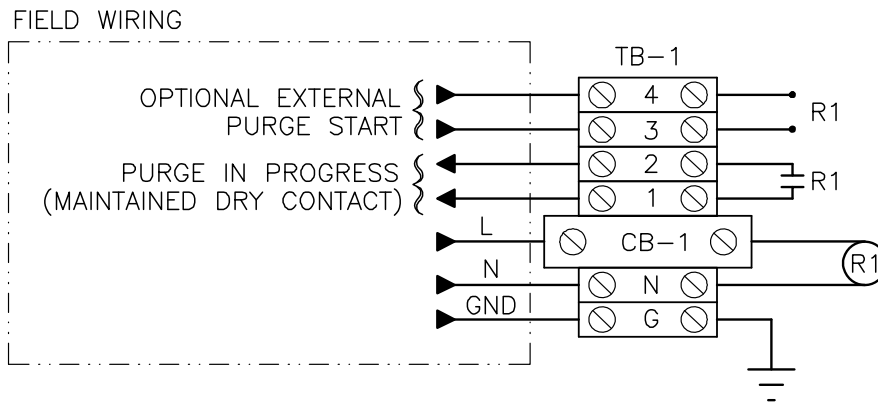

Figure 3.3

If a VELTRON DPT-plus is used in conjunction with the AUTO-purge III panel, a "smart" relay (R1) will be installed in the panel to perform purge management. See Figure 3.4 below for wiring details.



NOTE: CB-1 IS OMITTED IF POWER IS 24V.

Figure 3.4

If means other than an Air Monitor "smart" transmitter is used to Start/Stop the purge cycle, the power provided must match the coil voltage of SV-1A, SV-1B, and SV-2 (i.e., 24VDC, 24VAC, or 120VAC).

Optional Panel Heater (TB-2). Customer to provide 120VAC, 3.2 amps minimum.

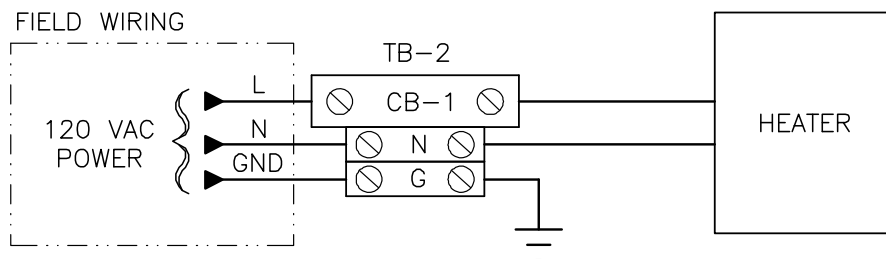

Figure 3.5

4 – SET-UP

This Section should be performed only after installation has been verified in accordance with Section 3.

4.1 – VERIFICATION OF PURGE PRESSURE

1. Verify there is no purge start command from flow transmitter or DAS. (Refer to flow transmitter or DAS operating instructions).
2. Open supply air valve HV-1 fully.
3. Verify air pressure as read on pressure gauge PI-1 is between 80 and 125 psig. If not, adjust supply air pressure accordingly.
4. To the test tee installed on the total pressure sensing line at the flow measuring device (see Section 3.4), connect a 0-100 psig pressure gauge.
5. Initiate the AUTO-purge cycle (refer to flow transmitter or DAS operating instructions), observe and record the pressure indicated on test gauge. Pressure should be at least 15 psig. If not, increase supply air pressure, decrease signal line length between AUTO-purge panel and flow measuring device, or increase signal line size. If initial pressure is at least 15 psig but drops significantly during the AUTO-purge cycle, increase the compressor or accumulator tank capacity or reduce the purge duration (but not less than 30 seconds).
6. Repeat Steps 4 and 5 for the static pressure sensing line.
7. Retain the recorded pressures from Steps 5 and 6 as these will be a reference point for future tests.
8. Remove gauge installed in Step 4 and seal tee.

5 – OPERATION

In order for the AUTO-purge III panel to operate, it must receive a start command (activation), consisting of a powered contact closure for the duration of the purge cycle.

Air Monitor's "smart" transmitters (VELTRON II, VEL-trol II, and MASS-tron II) are specifically designed to manage an AUTO-purge III panel. It is highly recommended that one of these transmitters be used. Purge cycle parameters (frequency, duration, and after-purge duration) are all set via transmitter programming. See specific IO&M Manual for details.

If a VELTRON DPT-plus is used in conjunction with the AUTO-purge III panel, the "smart" relay installed in the panel will be performing the purge management. The supplied "smart" relay operating instructions should be consulted when verifying/changing any of the purge parameters.

If another method of activation is utilized (such as a manual switch or BAS), user must be aware that process signal to transmitter or gauge will be lost during the duration of the purge cycle and complete signal recovery may take up to a minute after the activation signal is removed.

Once Set-Up is complete per Section 4, the AUTO-purge III should continue to function without any further operator interface.

CAUTION

If the AUTO-purge III panel is not going to be utilized immediately or rendered inoperable for any length of time, one of the following steps should be taken to preclude station or probe pluggage.

1. The airflow station or probe signal lines must be connected to a constant supply of 5 psig clean, dry, oil-free air.*
2. The airflow station or probe signal lines must be manually purged daily by applying 80 to 100 psig clean, dry, oil-free air for at least 5 minutes to each port.*

*Remove or isolate signal lines to flow transmitter prior to applying any purge air.

6 – VERIFICATION OF PURGE PERFORMANCE

This Section details a method of determining if the AUTO-purge III panel is effectively keeping total and static sensing ports free from clogging.

At periodic intervals, Steps 4 through 6 of Section 4.1 should be performed. If either the total or static pressure sensing lines indicate an increase in pressure (without any increase in supply air pressure) of 10% or greater than the initial test pressure (recording during Set-Up), clogging could be occurring.

Probe should be removed, inspected, and cleaned if necessary. After probe is reinstalled, Steps 4 through 6 of Section 4.1 should be performed and new pressure readings recorded.

To preclude reclogging, one or more of the following steps should be taken.

1. Increase purge frequency.
2. Increase purge pressure.*
3. Increase compressor or accumulator tank capacity.
4. Increase purge duration.

*If pressure is increased, steps 4 through 6 of Section 4.1 must be performed to establish new test pressures for comparison.

7 – MAINTENANCE

The AUTO-purge III panel does not contain any parts requiring special periodic maintenance. The following maintenance steps are not requirements but guidelines for establishing a maintenance program.

7.1 – INSPECTION

- Verify that pressure gauge PI-1 is reading according to Section 4.
- Verify all tubing connections (inside and outside) are secure.
- Verify wiring terminations are secure and corrosion free.

8 – TROUBLESHOOTING

<i>Problem</i>	<i>Solution</i>
<p>AUTO-purge cycle does not occur.</p>	<ul style="list-style-type: none"> – Verify wiring is correct per Transmitter I,O&M Manual. – Verify pressure at PI-1 is correct. See Section 4.1.
<p>If after following the Troubleshooting steps the AUTO-purge III continues to operate improperly, contact the Service Department for further assistance (see Section 9).</p>	

9 – CUSTOMER SERVICE

9.1 – CUSTOMER SERVICE/TECHNICAL SUPPORT

Air Monitor Corporation provides in-house technical support for our products:

Monday through Friday
7 am to 5 pm (pst)
Phone: 707-544-2706 or 1-800-AIRFLOW
Fax: 707-526-2825

Additionally, on-site technical assistance is available. Before contacting the Customer Service Department, please ensure any applicable troubleshooting steps outlined in Section 8 have been performed.

9.2 – REPAIRS/RETURNS

If after contacting the Customer Service Department it is determined that equipment will require return to Air Monitor Corporation for further repair, a Return Authorization number will be issued by the Customer Service Department. A Confirmation of Return Authorization with shipping instructions will be sent via facsimile.

Equipment to be returned to Air Monitor should be returned in its original shipping container if possible. If this is not possible, ensure equipment is packaged sufficiently to protect it during shipment.

CAUTION
All damage occurring during transit is the Customer's responsibility.

List the Return Authorization (R/A) number on the packing list and clearly mark this number on the outside of each shipping container.

Costs associated with return of equipment to Air Monitor are the customer's responsibility regardless whether the repair/return is under warranty.

9.3 – WARRANTY REPAIRS/RETURNS

Once the Customer Service Department determines that the equipment repair is under warranty, the item will be repaired and returned to the customer at no charge.

9.4 – NON-WARRANTY REPAIRS/RETURNS

Customer will be invoiced for all parts and labor required for the repair of equipment. Return shipping charges will also be added to invoice.

9.5 – FIELD SERVICE

Requests for field service should be made to the Customer Service Department, who will coordinate sending a technician to customer's site.

Phone: 707-544-2706 or 1-800-AIRFLOW
Fax: 707-526-2825

Upon completion of work, technician completes a Field Service Report and gives a copy to the customer. Field service is charged on a daily basis and all travel expenses are also added to customer's invoice.