

Installation, Operation, and Maintenance Manual

VEL-trol II

Microprocessor Based
Pressure & Flow "Smart" Transmitter

Versions 5.3X

Installation, Operation & Maintenance

Air Monitor Corporation provides complete
technical support between the hours of
7 a.m. and 5 p.m. PST, M-F

Contact our Service Department
Toll Free: 1-800-AIRFLOW

or fax us at 1-707-526-2825



TABLE OF CONTENTS

INSTRUMENT WARRANTY	i
 SECTION 1 – GENERAL INFORMATION	
1.1 DESCRIPTION	1
1.2 THEORY OF OPERATION	1
 SECTION 2 – PERFORMANCE SPECIFICATIONS	
2.1 TRANSMITTER	2
2.2 INDICATION	2
2.3 INPUTS/OUTPUTS	2
2.4 POWER	2
 SECTION 3 – FEATURES	
3.1 USER SETUP MENU	3
3.2 CONTROLLER OUTPUT	3
3.3 TRANSMITTER HOLD	3
3.4 AUTOMATIC ZEROING	3
3.5 AUTO-purge MANAGEMENT (option)	3
3.6 ALARM (option)	4
3.7 SPECIAL FUNCTIONS (option)	4
3.8 DATA DISPLAY	5
3.9 K-FACTOR	5
3.10 FLOW/DIFFERENTIAL PRESSURE CALCULATOR	5
3.11 NETWORK	5
3.12 MULTIPLE OPERATING POWER SELECTIONS	5
3.13 ENCLOSURE	5
 SECTION 4 – INSTALLATION	
4.1 RECEIVING AND INSPECTION	6
4.2 LOCATION	6
4.3 MOUNTING	6
4.4 PROCESS CONNECTIONS	7
4.5 POWER/SIGNAL CONNECTIONS	8-10
4.6 INPUT/OUTPUT SELECTION	11
4.7 DISPLAY CONTRAST ADJUSTMENT	11
 SECTION 5 – OPERATION	
5.1 INTRODUCTION	12
5.2 START-UP	12
5.3 NORMAL OPERATION	13
5.4 CONFIGURATION	14
5.5 PUSHBUTTON DEFINITION	15
5.6 CONFIGURATION PROGRAMMING	16-18
5.7 OPERATOR PASSWORD SELECTION	19
5.8 TRANSMITTER SCALING & CONFIGURATION	20-27
5.9 LOW PASS FILTER SELECTION	28

TABLE OF CONTENTS

SECTION 5 – OPERATION (con't)

5.10	AUTO-zero CONFIGURATION	29
5.11	AUTO-purge CONFIGURATION	30
5.12	AUTO-calibration CONFIGURATION	31
5.13	ALARM CONFIGURATION	32-33
5.14	CONTROLLER CONFIGURATION	34-36
5.15	SPECIAL FUNCTION CONFIGURATION	37-38
5.16	K-FACTOR CONFIGURATION	39-40
5.17	STANDARD DISPLAY CONFIGURATION	41-43
5.18	ENHANCED DISPLAY CONFIGURATION	44-48
5.19	ANALOG OUTPUT CONFIGURATION	49
5.20	TRANSDUCER SPAN SELECTION	50
5.21	TRANSMITTER INPUT CALIBRATION	51
5.22	TRANSMITTER OUTPUT CALIBRATION	51
5.23	POWER SUPPLY CALIBRATION	52
5.24	TRANSDUCER CHARACTERIZATION SELECTION	53
5.25	NETWORK CONFIGURATION	54
5.26	MENU INACTIVITY TIMEOUT SELECTION	55

SECTION 6 – CALIBRATION

6.1	REQUIRED EQUIPMENT	56
6.2	PREPARATION	56
6.3	TRANSMITTER INPUT CALIBRATION	57-65
6.4	TRANSMITTER OUTPUT CALIBRATION	66-67

SECTION 7 – MAINTENANCE 68**SECTION 8 – TROUBLESHOOTING** 69-70**SECTION 9 – PARTS LIST** 71-72**SECTION 10 – CUSTOMER SERVICE** 73**APPENDIX A** 74-77

- BACnet over RS485 – Signal Wire Connections and Network Configuration
- LonWorks – Signal Wire Connections and Network Configuration
- Modbus over TCP – Signal Wire Connections and Network Configuration

INSTRUMENT WARRANTY

Air Monitor Corporation (hereinafter referred to as “Seller”) warrants that at the time of shipment, products sold pursuant to this contract will be free from defects in materials and workmanship, and will conform to the specifications furnished or approved in writing by Seller. No warranty is given that delivered products will conform to catalog sheets, data sheets, and the like, which are subject to change without notice.

Seller will repair or replace, at its option, any products listed under this warranty which is returned freight prepaid to Seller within the earlier of three (3) years after start-up or thirty-nine (39) months after shipment that, upon test and examination, proves defective within the terms of this warranty. The warranty period for any item repaired or replaced shall be for the time remaining on the warranty period of the original components. Purchaser shall notify Seller in writing of such defect within sixty (60) days of discovery of the defect.

This warranty does not extend to any product sold by Seller which has been the subject of misuse, neglect, accident, damage or malfunction caused by interconnection with equipment manufactured by others, improper installation or storage, or used in violation of instructions furnished by Seller, nor does it extend to any product which has been repaired or altered by persons not expressly approved by Seller. Nor does Seller warrant equipment against normal deterioration due to environment; nor items such as lamps, glass, and similar items subject to wear or burnout through usage. Adjustments for items or equipment not manufactured by Seller shall be made to the extent of any warranty of the manufacturer or supplier thereof.

Seller shall not be liable for any special or consequential damages or for loss of damage, directly or indirectly arising from the use of the products. Seller’s warranty shall be limited to replacement of defective equipment and shall not include field removal and installation expenses.

The warranty set forth above is in lieu of all other warranties either express or implied and constitutes the full extent of Air Monitor Corporation’s liability to the customer, or any other party for breach of warranty.

THERE ARE NO EXPRESS WARRANTIES EXCEPT AS SET FORTH HEREIN AND THERE ARE NO IMPLIED WARRANTIES OF MERCHANTABILITY OF FITNESS FOR ANY PARTICULAR PURPOSE, WHICH ARE PARTICULARLY DISCLAIMED.

NOTICE OF PROPRIETARY RIGHTS

This document contains confidential technical data, including trade secrets and proprietary information which are the sole property of Air Monitor Corporation. The use of said data is solely limited to use as specified herein. Any other use is strictly prohibited without the prior written consent of Air Monitor Corporation.

1 – GENERAL INFORMATION

1.1 – DESCRIPTION

The VEL-trol II is an ultra-low differential pressure "smart" transmitter-controller designed to convert the low magnitude pressure signals generated by airflow stations and probes, or static pressure sensors into dual transmitter output signals (4-20mA, 0-5VDC or 0-10VDC) linear to pressure or flow, and compares this process signal against user selectable setpoint to generate a P,I,1/D analog controller output.

Each VEL-trol II is equipped with numerous standard features: A multi-line LCD used during configuration/calibration and for display of process; AUTO-zero for elimination of transmitter zero error; user selectable primary signal noise filter, input power isolation; capability of 10:1 flow or 100:1 pressure turndown; NEMA 1 enclosure, and a long list of construction options.

1.2 – THEORY OF OPERATION

High and low pressure signals generated by airflow stations and probes, or static pressure sensors act upon opposite sides of a flexible diaphragm within the transducer. The differential between the two pressure signals displaces the diaphragm; the magnitude of the displacement being measured creates an electrical DC output from the transducer. After undergoing A/D conversion, the resulting digital signal representing differential pressure or velocity pressure can be "manipulated" within the microprocessor: square rooted for velocity or flow application; compared against the controller setpoint to generate the required controller output; scaled for units of measure and area for process outputs; filtered and scaled for local data display and utilized in performing a Special Function (see Section 3 – Features). The built-in microprocessor runs the program that provides the following basic functions: Timing, logic, and mathematical operations, analog input signal multiplexing, controller tuning, action and setpoint selection, analog input/output calibration, digital input (contact closure) detection, output relay operation, automatic zeroing valve operation, User Setup menu system, display (LCD) indication, and individual LED indication.

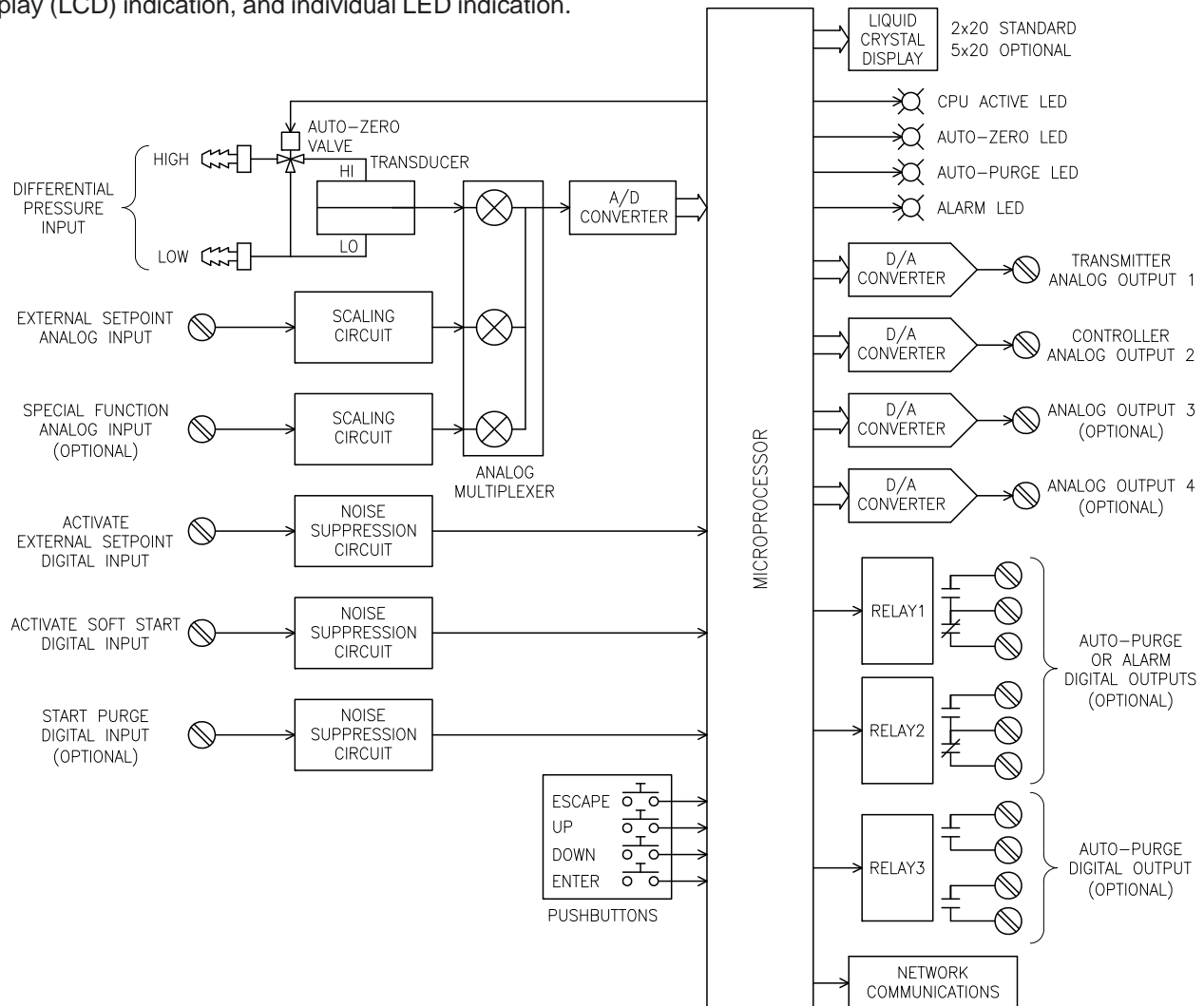

2 – PERFORMANCE SPECIFICATIONS

2.1 – TRANSMITTER

Ranges.	<u>Natural Spans</u>	<u>Bi-Polar Natural Spans</u>
	0 to 25.00 IN w.c.	
	0 to 10.00 IN w.c.	–10.00 to +10.00 IN w.c.
	0 to 5.00 IN w.c.	– 5.00 to +5.00 IN w.c.
	0 to 2.00 IN w.c.	– 2.00 to +2.00 IN w.c.
	0 to 1.00 IN w.c.	– 1.00 to +1.00 IN w.c.
	0 to 0.50 IN w.c.	– 0.50 to +0.50 IN w.c.
	0 to 0.25 IN w.c.	– 0.25 to +0.25 IN w.c.
	0 to 0.10 IN w.c.	– 0.10 to +0.10 IN w.c.
	0 to 0.05 IN w.c.	– 0.05 to +0.05 IN w.c.

Span Rangeability. The calibrated span can be down ranged to 40% of the Natural Span.

Accuracy. 0.1% of Natural Span, including non-linearity, hysteresis, deadband, and non-repeatability.

Stability. ±0.5% of Natural Span for six months.

Transducer Response Time. 0.5 second to reach 98% of a step change.

Temperature Effect.
Zero. None; corrected by AUTO-zero.
Span. 0.015% of Full Span/°F.

Mounting Position Effect. None; corrected by AUTO-zero.

Span and Zero Adjustment. Digital, via internally located push-buttons.

Automatic Zeroing.
Accuracy. Within 0.1% of calibrated span.
Frequency. Every 1 to 24 hours on 1 hour intervals.

Low Pass Filtration. Response time to reach 98% of a step change is adjustable from 2.0 to 256.0 seconds.

Max Zero Elevation and Suppression. 100% of Natural Span.

Overpressure and Static Pressure Limit. 25 psig.

Temperature Limits. –20 to 180°F Storage; +40 to 140°F Operating.

Humidity Limits. 0-95% RH, non-condensing.

2.2 – INDICATION

Displays. Standard 2 line x 20 character LCD provides two lines of data display. Optional backlit graphical LCD provides up to 5 lines of data display. LED's indicate CPU activated, AUTO-zero in progress, AUTO-zero over-ranged, AUTO-purge in progress, and auxiliary alarm "on" status.

2.3 – INPUTS/OUTPUTS

Analog Inputs. A single input is field configurable via jumper for 0-5VDC, 0-10VDC, or 4-20mADC. For use with optional special function.

Analog Outputs. Dual transmitter and controller outputs are individually configurable via jumper for 0-5VDC, 0-10VDC, or 4-20mADC. Two additional outputs are optionally available.

Controller. Controller output type is P,I,1/D, user selectable direct or reverse acting. Controller setpoint is user selectable as internal or via external analog input.

Digital Inputs. Dry contacts for AUTO-purge external start, and purge interrupt.

Digital Outputs. Dry contacts for optional Alarm or AUTO-purge activation/acknowledgment. Contacts are rated for:

- Maximum 3 amps @ 24 to 120VAC
- Maximum 3 amps @ 24VDC
- Maximum 0.5 amp @ 48VDC

Network Communication. Optional ModBus TCP/IP over Ethernet, BACnet or Lonworks.

2.4 – POWER

Power Supply. Standard 24VAC or 24VDC. Optional 120VAC via external transformer.

Power Consumption.

	Standard		w/AUTO-purge	
	In Rush	Contin	In Rush	Contin
24VAC	14.4VA	14VA	85VA	73VA
24VDC	9.6W	9.0W	37W	37W
120VAC	19.2VA	18.67VA	106VA	92VA

Circuit Protection. Power input is isolated, fused, and reverse polarity protected.

3 – FEATURES

3.1 – OPERATOR SETUP MENU

The microprocessor program contains a Operator Setup menu system for setting user selectable parameters. Four pushbuttons, **ESC**, **UP**, **DN**, **ENT**, allow the user access to the menu for setting configuration modes and values. Refer to the Configuration Programming (Section 5.6) instructions for operation details. Also contained in the Operator Setup menu is all input and output calibration. The calibration method is completely digital and contains no analog potentiometer adjustments which are susceptible to drift. Non-volatile memory is used for storing all setup parameters and calibration values, and will remain unchanged after set, even when power to the unit is off.

3.2 – CONTROLLER OUTPUT

The controller in the VEL-trol II incorporates the three control modes of proportional, integral, and inverse derivative to permit tuning of the controller action. Controller tuning, action (direct or reverse), setpoint (internal or internal/external) and variable to be controlled (monitored process or Special Function) are set via the Operator Setup menu. The controller output and/or setpoint can be displayed on the Enhanced display during *Normal* operation. Controller setpoint is displayed on standard display during *Normal* operation.

3.3 – TRANSMITTER HOLD

Certain operations performed by the microprocessor place the unit into a *Hold* mode. This occurs when the Operator Setup menu system is activated, when an AUTO-zero is performed, or when an AUTO-purge cycle is in progress. When in *Hold*, all *Normal* mode processing is halted and outputs are held at their last value prior to *Hold*. *Normal* operation is indicated by the "CPU Active" LED flashing at a rate of four times per second. A *Hold* mode is indicated by the "CPU Active" LED flashing at a rate of one time per second.

3.4 – AUTOMATIC ZEROING

At periodic intervals the microprocessor will automatically execute an AUTO-zero cycle consisting of the following sequence: The transmitter output and display signals are put on *Hold*; a valve is activated which disconnects the process high pressure from the high port of the transducer and connects the process static pressure to both sides of the transducer, creating a true zero differential pressure; after a brief stabilization period, the transducer zero offset signal is measured and stored in memory; the valve is deactivated and after a brief period for process signal stabilization, the *Hold* is released and *Normal* process measurement resumes. During *Normal* operation, the zero offset value stored in memory is subtracted from subsequent transducer readings until the next AUTO-zero cycle occurs and repeats the process. AUTO-zero On/Off and Interval are available and configurable using the Operator Setup menu.

3.5 – AUTO-purge MANAGEMENT (option)

For "dirty process air" applications requiring the use of an Air Monitor AUTO-purge system, the VEL-trol II provides the capabilities of establishing purge frequency and duration, while also giving the user a choice of either internally timed cycle frequency or externally triggered purge initiation. During the purge cycle all transmitter outputs are maintained at their last value prior to the start of the purge cycle.

3.6 – ALARM (option)

The VEL-trol II Alarm Option provides the means for having the process signal compared to user selectable alarm points and automatically activates a form C relay to generate dry contact alarm signal(s). User selectable alarm configurations of Low/High, Low1/Low2, and High1/High2 plus Alarms On/Off, Setpoints, Dead Bands, and Delays are configurable via the Setup menu. Alarm Setpoints can be displayed on an Enhanced Display during *Normal* operating mode.

One choice among three alarm types are available to the user: Low/High; Low1/Low2; or High1/High2. An Alarm Delay is available, if implemented (any time setting greater than zero), any condition that would normally cause an alarm, triggers the delay timer first. If the alarm condition still exists after the delay times out, then the appropriate alarm relay(s) are activated. The "Auxiliary Alarm On" LED will light whenever any alarm relay is activated. Alarm On/Off, Type, Setpoints, Deadbands, and Delays are available and configurable using the Setup menu. The Alarm Setpoints can be displayed on the Enhanced Display during *Normal* operation.

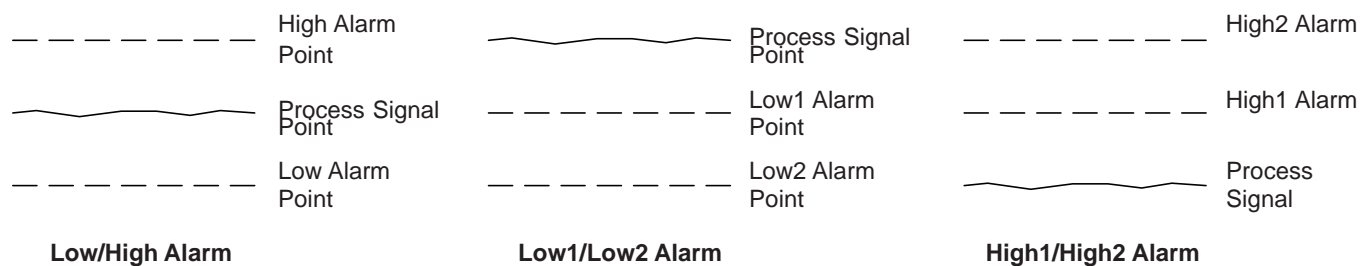

3.7 – SPECIAL FUNCTIONS (option)

When used in conjunction with an external input (second transmitter) applied to the special function input terminals, the VEL-trol II can perform one of the Special Functions listed below. Within the Operator Setup menu, both the external input and the internal transmitter signals can be individually scaled to achieve a correct weighted basis. The resulting Special Function output is available as an analog output and/or for the display on the optional Enhanced Display. When % Deviation is selected as Special Function Type, contact closure is available for alarm/notification. Special Function ON/OFF and Type are available and configurable using the Operator Setup menu.

%Deviation. $| \text{EXTERNAL} - \text{INTERNAL} | / | \text{EXTERNAL} |$. This function has Alarm Setpoint, Deadband, and Delay that are configurable via the Operator Setup menu. (If this function is selected, Alarm Option, Section 3.6, is not available.)

Summed Flow. $\text{INTERNAL} + \text{EXTERNAL}$

Averaged Flow. $(\text{EXTERNAL} + \text{INTERNAL}) / 2$

Delta Flow, Internal - External. $\text{INTERNAL} - \text{EXTERNAL}$

Delta Flow, External - Internal. $\text{EXTERNAL} - \text{INTERNAL}$

Low Select. Selecting the lesser of the INTERNAL and EXTERNAL signals.

High Select. Selecting the greater of the INTERNAL and EXTERNAL signals.

3.8 – DATA DISPLAY

The Standard Display is a 2 line by 20 character Liquid Crystal Display (LCD) capable of displaying the transmitter signal in engineering units (such as IN w.c., FPM, CFM) and a user selectable second line of data when in *Normal* operation. It is also utilized by the Operator Setup menu for displaying the menu parameters and values.

The optional Enhanced Display is a backlit graphical LCD and replaces the Standard Display. It is capable of displaying the transmitter signals in Engineering units plus other signals that become available when the Alarm and/or Special Function options described in Sections 3.6 and 3.7 are implemented. It can also display a user settable I.D. number using any combination of standard ASCII characters. It is also used by the Operator Setup menu for displaying the menu parameters and values. Configuring the Enhanced Display for *Normal* operation is done using the Operator Setup menu.

3.9 – K-FACTOR

The VEL-trol II is equipped with a K-factor feature which allows for the introduction of a bias and/or gain factor into the transmitter's flow calculations. The K-factor feature is intended to be used in two types of applications:

1. To adjust for flow measurement error as a result of highly distorted airflow induced by upstream or downstream flow disturbances.
2. To adjust the transmitter's output to bring it into close correlation with field measured flow data.

The K-Factor gain and bias values can be entered directly or the VEL-trol II can calculate these values based on measured and reference values from a 1 or 3 point airflow traverse.

3.10 – FLOW/DIFFERENTIAL PRESSURE CALCULATOR

The VEL-trol II is equipped with an integral calculator feature that allows the user to determine the maximum flow or differential pressure from the appropriate variables. This feature allows the user to determine input or output values at various points of the process or new values if the process parameters have changed. Also, the calculator can be used to implement a single-point density compensation for operating temperature and/or absolute pressure.

3.11 – NETWORK (option)

The VEL-trol II can be provided with optional ModBus TCP/IP over Ethernet, BACnet or Lonworks for serial data communication.

3.12 – MULTIPLE OPERATING POWER SELECTIONS

The VEL-trol II can be powered by 24VAC or 24VDC.

3.13 – ENCLOSURE

The VEL-trol II transmitter is furnished in a NEMA 1 aluminum enclosure with external, unitary plug in terminal strips for ease of installation and removal. An optional junction box is available for applications requiring enclosed field wiring.

4 – INSTALLATION

4.1 – RECEIVING AND INSPECTION

- Carefully remove the VEL-trol II from the shipping container taking ESD (electrostatic discharge) precautions.
- Inspect unit for any damage. If damaged, contact freight company.
- Review the Factory Set-Up Information Sheet provided with the unit and verify the W.O. # and Serial # match those on the unit. Verify that the configuration recorded on the Factory Set-Up Information Sheet is correct for your application. If not, contact Air Monitor's Customer Service Department at 1-800-AIRFLOW for further guidance.

Note: The VEL-trol II has been configured and calibrated to customer specified parameters (see "Factory Setup Information Sheet" provided with unit), and requires no additional calibration/verification prior to installation.

4.2 – LOCATION

- The VEL-trol II is housed in a NEMA 1 enclosure which provides some degree of protection which is sufficient for most clean indoor locations.
- Where additional protection is deemed necessary, the VEL-trol II should be mounted in an enclosure with adequate NEMA rating.
- The ambient temperature of the selected mounting location must be between 40° – 140°F. Consideration should be given to units installed in enclosures exposed to direct sunlight.
- The selected mounting location should be rigid and free of vibration.

4.3 – MOUNTING

Tools Required: Electric Drill; #25 (0.1495") or #26 (0.1470") Drill Bit; Screwdriver or Nutdriver; Four #8 - 32 Self-Tapping Machine Screws

- The VEL-trol II can be mounted in any position provided it is secured using all four mounting slots.
- Reasonable consideration should be given to clearances for pressure and electrical connections.
- Once a suitable location is found, mark the centers of the four mounting slots and drill four pilot holes. With the unit in position, install the four #8 - 32 screws.

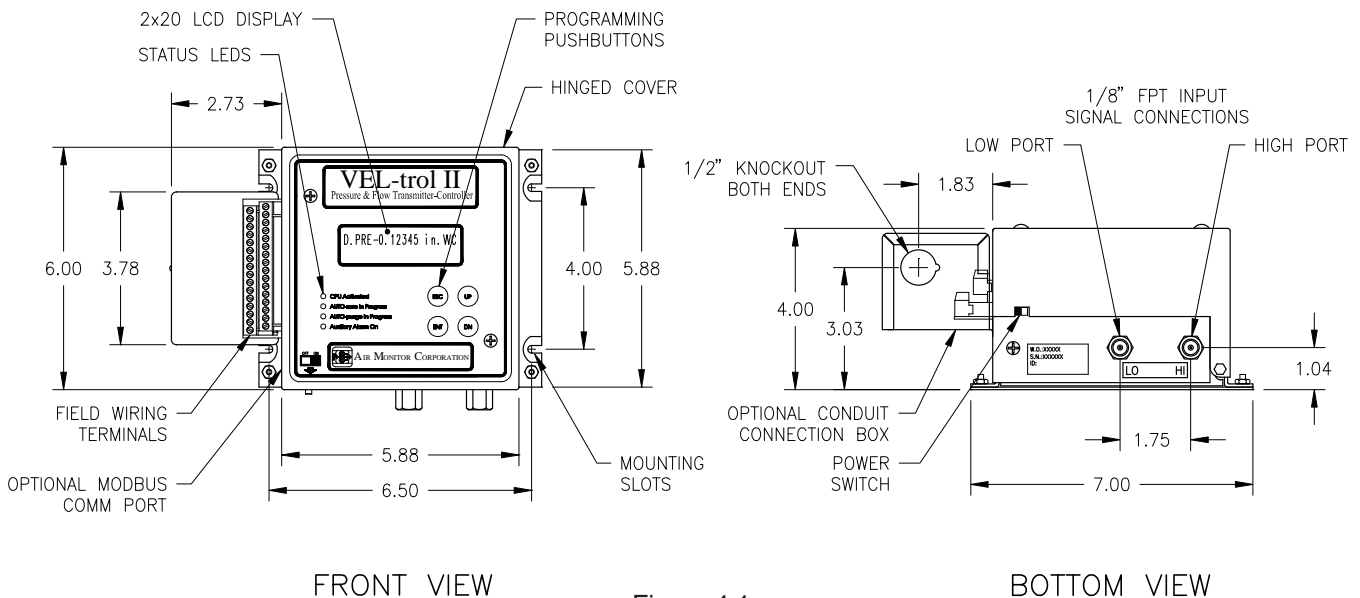

Figure 4.1

4.4 – PROCESS CONNECTIONS

The VEL-trol II comes standard with brass 1/8" FPT connections (or special fittings if ordered). To these connections the customer can install fittings required for the type of tube/pipe used to connect to process sensor (i.e. flow station, flow probe, static pressure sensors).

When connecting the VEL-trol II to an airflow measuring device, connections must be completed as follows:

- High Port on VEL-trol II connects to Total Pressure from airflow measuring device.
- Low Port on VEL-trol II connects to Static Pressure from airflow measuring devices.

When connecting VEL-trol II for positive room pressurization, connections must be completed as follows:

- High Port on VEL-trol II connects to sensor from monitored room.
- Low Port on VEL-trol II connects to reference sensor.

When connecting VEL-trol II for negative room pressurization, connections must be completed as follows:

- High Port on VEL-trol II connects to reference sensor.
- Low Port on VEL-trol II connects to sensor from monitored room.

Although any size of tube/pipe can be used, the response time of the VEL-trol II to process change increases with increasing tube/pipe size or increasing in tube/pipe length.

CAUTION

- Selected fittings should be compatible with the brass 1/8" FPT bulkhead connection, and installed using an appropriate thread lubricant/sealant.
- When signal fittings are added or removed, use a 9/16 wrench to prevent the 1/8" FPT bulkhead fitting from turning.
- It is extremely important that no pressure be present in signal tubing at the time of installation, and the orientation of high and low pressure signal lines is maintained between the source and the VEL-trol II.

If process being measured contains humidity or moisture, it is recommended a drip leg with drain on each tube/pipe be installed to preclude the migration of water into the VEL-trol II. See Figure 4.2. for typical drip leg installation.

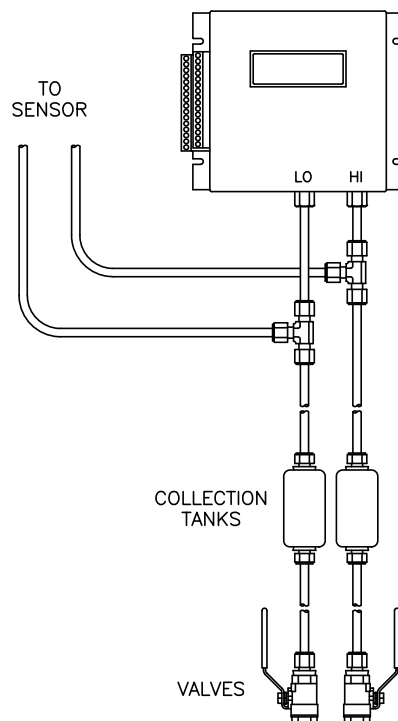

Figure 4.2

CAUTION

Migration of water into the VEL-trol II will void warranty.

4.5 – POWER/SIGNAL CONNECTIONS

All power and signal wiring is done at the terminal strip at the left side of the VEL-trol II. Figure 4.3 below represents the terminal strip and the connections for power input and the various inputs/outputs available (review Factory Set-Up Information Sheet for which inputs/outputs are included with your unit).

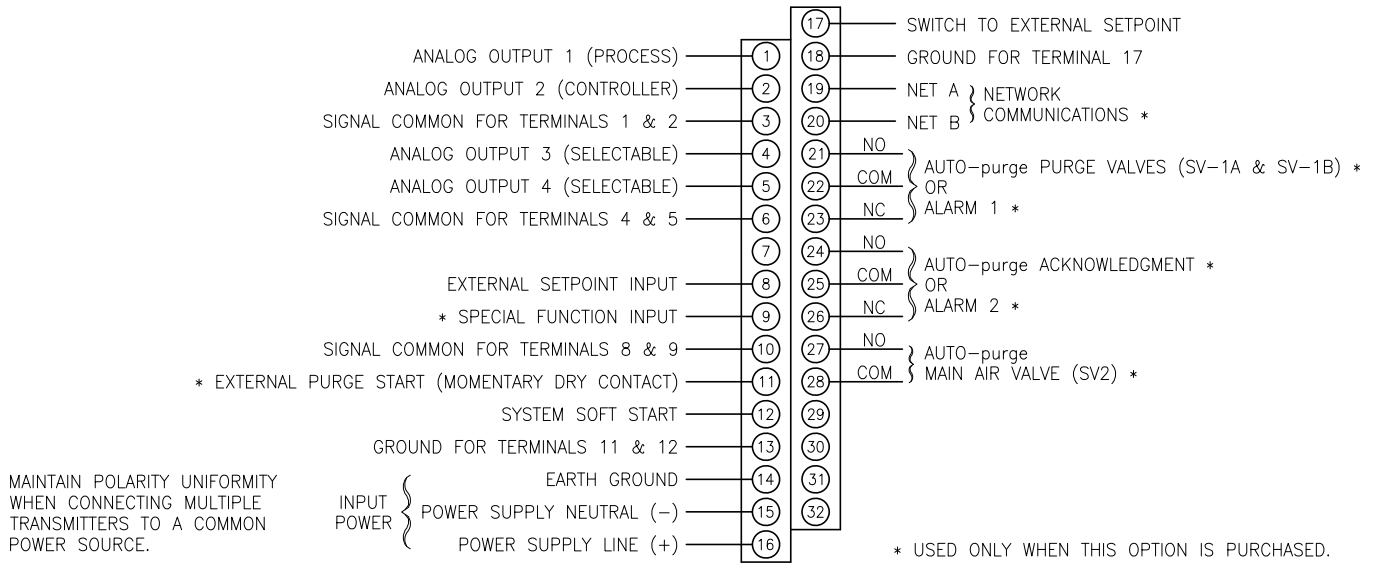

Figure 4.3

CAUTION

When connecting or disconnecting any wiring to the VEL-trol II, the unit's power switch (see Figure 4.1) must be in the OFF position.

WIRING.

It is recommended that any power wiring be 14 awg to 18 awg, and any signal wiring should be 14 awg to 22 awg. 14 awg is the maximum wire gauge that the terminal strip can accommodate.

No more than two wires should be connected to any one terminal. 18 awg is the maximum gauge wire that can be doubled up in one terminal.

To facilitate wiring and any future removal of the VEL-trol II, each terminal strip is removable from the unit. Remove terminal strip marked 1-16 first by pulling sideways, away from the unit. A flat blade screwdriver can also be used to gently pry strip free. Once the strip is removed, the second strip marked 17-32 can be similarly removed.

If the unit was furnished with optional conduit connection box, loosen screw, and remove cover to gain access to the terminal strip.

4.5 – POWER/SIGNAL CONNECTIONS (con't)

Analog Output 1 (Terminals 1 and 3). These outputs are sourced (powered) by the VEL-trol II (refer to Section 4.6 for selection).

- 4-20mADC: Maximum load resistance is 750 ohms.
- 0-10VDC: Minimum load resistance is 5000 ohms.
- 0-5VDC: Minimum load resistance is 2500 ohms.

Review Factory Set-Up Information Sheet provided with the unit for your signal type.

Analog Output 2, Controller (Terminals 2 and 3). These output is sourced (powered) by the VEL-trol II (refer to Section 4.6 for selection).

- 4-20mADC: Maximum load resistance is 750 ohms.
- 0-10VDC: Minimum load resistance is 5000 ohms.
- 0-5VDC: Minimum load resistance is 2500 ohms.

Review Factory Set-Up Information Sheet provided with the unit for your signal type.

Analog Output 3 and 4 (Terminals 4, 5, and 6). These outputs are sourced (powered) by the VEL-trol II (refer to Section 4.6 for selection).

- 4-20mADC: Maximum load resistance is 750 ohms.
- 0-10VDC: Minimum load resistance is 5000 ohms.
- 0-5VDC: Minimum load resistance is 2500 ohms.

Review Factory Set-Up Information Sheet provided with the unit for your signal type.

External Setpoint Input (Terminals 8 and 10). Input is required to be sourced (powered) from the customer. Input can be 4-20mA, 0-5V, or 0-10V (refer to Section 4.6 for selection).

Special Function Input (Terminals 9 and 10). Input is required to be sourced (powered) from the customer. Input can be 4-20mA, 0-5V, or 0-10V (refer to Section 4.6 for selection).

External Purge Start (Terminals 11 and 13). Customer to provide momentary (0.5 to 10 second unpowered) dry contact to initiate purge cycle.

System Soft Start (Terminals 12 and 13). Customer to provide continuous dry contact (unpowered) to initiate soft start.

Input Power (Terminals 14, 15, and 16). Power required by VEL-trol II must be connected to terminals 15 and 16. Earth ground should be connected to Terminal 14. When powering multiple units from one power source, polarity must be maintained.

Switch to External Setpoint (Terminals 17 and 18). Customer to provide a continuous dry contact (unpowered) to enable External Setpoint.

Network Communications (Terminals 18, 19, and 20).

	Terminal 18	Terminal 19	Terminal 20
BACnet	Network ground	Net A or Net+	Net B or Net-
LonWorks	Network ground	LonWorks A	LonWorks B
Modbus TCP/IP	Connection is made via Ethernet cable port (see Figure 4.1) below terminal strip		

4.5 – POWER/SIGNAL CONNECTIONS (con't)

AUTO-purge Purge Valves (SV-1A & SV-1B) or Alarm 1 (Terminals 21, 22, and 23).

- For AUTO-purge Option.
 - Customer to connect Terminals 21 and 22 to AUTO-purge panel (Terminal 23 not used).
 - Contacts close upon AUTO-purge cycle initiation, remain closed through the programmed Purge Duration, and open at the start of the After Purge Duration (see Section 5.11).
- For Alarm Option.
 - Customer to connect according to desired alarm logic. Figure 4.3 indicates de-energized (alarm off) state.

Note: Contacts can be dry (un-powered) or internally powered with 24 VAC/DC through the selection of jumpers J19 & J20 (see Figure 4.4). Power (ac or dc) is the same provided at Terminals 15 & 16. For Purge option, unit is supplied with contacts powered. For Alarm option, unit is supplied with contacts un-powered.

AUTO-purge Acknowledgment or Alarm 2 (Terminals 24, 25, and 26).

- For AUTO-purge Option. Acknowledgment contact for customer use. Contacts close upon AUTO-purge cycle initiation, remain closed through the entire purge cycle (see Section 5.11).
- For Alarm Option. Customer to connect according to desired alarm logic. Figure 4.3 indicates de-energized (alarm off) state.

Note: Contacts can be dry (un-powered) or internally powered with 24 VAC/DC through the selection of jumpers J21 and J22 (see Figure 4.4). Power (ac or dc) is the same provided at Terminals 15 and 16. For Purge option, unit is supplied with contacts un-powered. For Alarm option, unit is supplied with contacts un-powered.

AUTO-purge Main Air Valve (SV-2)(Terminals 27 and 28).

- For AUTO-purge Option. Customer to connect Terminals 27 and 28 to AUTO-purge Panel.

Note: Contacts can be dry (un-powered) or internally powered with 24 VAC/DC through the selection of jumpers J23 & J24 (see Figure 4.4). Power (AC or DC) is the same provided at Terminals 15 & 16. For Purge option, unit is supplied with contacts powered.

Figure 4.4 depicts location of Jumpers J19 through J24, on the left side of the I/O board (CPU board will need to be removed to gain access).

Jumper should be positioned on the 2 pins that correspond to desired option: INT – Powered; EXT – Un-powered

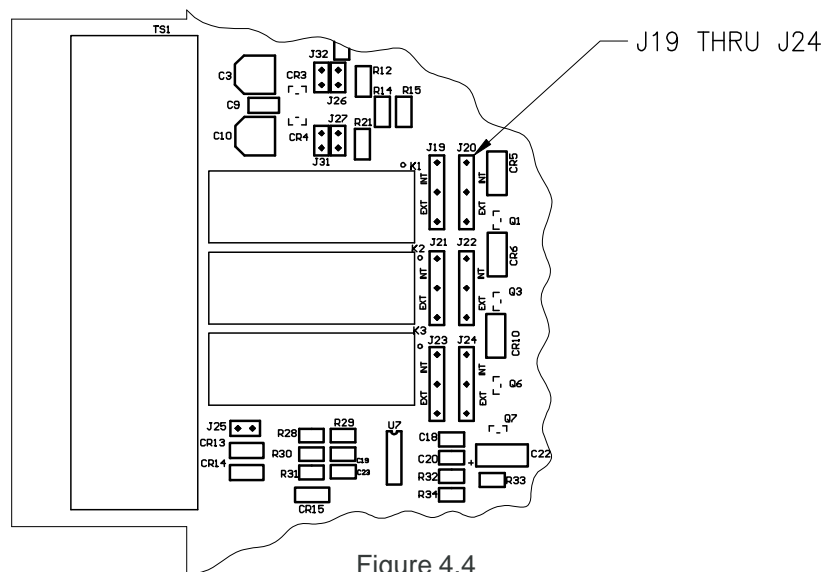

Figure 4.4

4.6 – INPUT/OUTPUT SELECTION

Selections of input and output signal types are made on the Jumper section of the I/O board, see Figure 5.1. Remove top cover to gain access to the Jumper board.

Figure 4.5 depicts the Jumper section and the pins associated with specific input and output signal types.

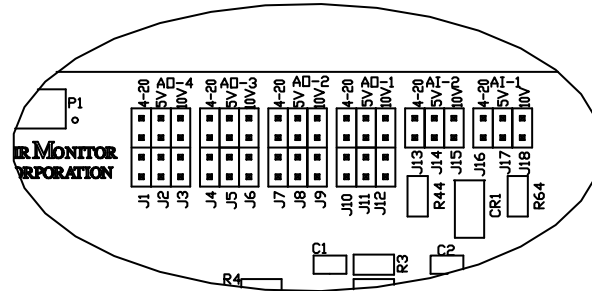

Figure 4.5

Table 4.1 lists the identifier for each row of pins to be jumpered for a specific input or output signal type.

	SIGNAL TYPE		
	4-20mADC	0 to 5 Volts	0 to 10 Volts
Analog Output (AO-1) (Transmitter)	J10	J11	J12
Analog Output (AO-2) (Controller)	J7	J8	J9
Analog Output (AO-3) (Optional)	J4	J5	J6
Analog Output (AO-4) (Optional)	J1	J2	J3
Analog Input (AI-1) (External Setpoint Input)	J16	J17	J18
Analog Input (AI-2) (Special Function Input)	J13	J14	J15

Table 4.1

The necessary jumpers have been installed at the Factory for customer specified inputs and outputs (see Factory Set-Up Information Sheet). The availability of inputs and outputs depends on options purchased.

To change the signal type of an available input or output, remove all jumpers from the present signal type pins and install them on the desired signal type pins.

Inputs have a single jumper covering two pins, and outputs have two jumpers covering four pins.

4.7 – DISPLAY CONTRAST ADJUSTMENT

To compensate for different ambient lighting conditions and viewing angles, the VEL-trol II display's contrast can be adjusted for optimum visibility.

Contrast is adjusted using potentiometer R1 on CPU board (see Figure 5.1). To gain access to R1:

- Remove the two 10-32 screws on front cover and pull the cover straight and to the right.
- Turn R1 clockwise to increase contrast (darken characters relative to background) and counterclockwise to decrease contrast.

5 – OPERATION

5.1 – INTRODUCTION

The VEL-trol II has been configured and calibrated at the Factory to customer specified parameters which are recorded on the VEL-trol II Factory Set-Up Information Sheet, included with the unit. Review this information and verify that the VEL-trol II setup is correct for your applications. If any problems or discrepancies are detected, contact Air Monitor's Customer Service Department at 1-800-AIRFLOW prior to proceeding.

5.2 – START-UP

1. After Installation has been verified in accordance with Section 4, turn power switch located at the lower front side to the ON position (see Figure 4.1).

2. Display will briefly indicate:



with the ■ progressing from left to right.

Followed by:

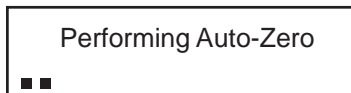

with the ■ progressing from left to right.

After approximately 10 seconds, the unit will return to *Normal* display mode, and green LED indicating "CPU Activated" will flash rapidly (4 times per second). This is *Normal* operation mode and no further user interface is required. If, however, user would like to verify configuration or change user selectable parameters, continue to Section 5.4 entitled "CONFIGURATION".

5.3 – NORMAL OPERATION

Under *Normal* operation the VEL-trol II's display will continuously indicate current process variables (and other parameters with enhanced display option).

AUTO-zero

At periodical intervals* (see Factory Set-Up Information Sheet provided with the unit) the AUTO-zero cycle will be initiated. When this occurs, the display will be frozen and all outputs will remain constant. During this cycle the "AUTO-zero in Progress" LED will be lit.

This cycle will not occur if AUTO-zero has been turned OFF in configuration programming (see Section 5.10).

The AUTO-zero cycle can be manually activated by user (if ON in configuration programming) by simultaneously pressing **ESC** and **UP**, then scrolling until Perform Auto-Zero is displayed, then press **ENT**.

If "AUTO-zero In Progress" LED remains on continuously (past the normal cycle time) or flashes rapidly, refer to Section 8 - Troubleshooting for required action.

AUTO-purge

If the AUTO-purge option has been installed at the factory (see Factory Set-Up Information Sheet), it will activate at periodic intervals*. When activated, display will be frozen and all outputs will remain constant. During this cycle, the "AUTO-purge In Progress" LED will remain lit. Length of cycle depends on purge duration and after-purge duration (see Factory Set-Up Information Sheet).

This cycle will not occur if AUTO-purge has been turned OFF in configuration programming (see Section 5.11).

The AUTO-purge cycle can be manually activated by user (if ON in configuration programming) by simultaneously pressing **ESC** and **UP**, then scrolling until Perform Auto-Purge is displayed, the press **ENT**.

Alarms

Alarms are available with either the Alarm Option or % Deviation (Alarm 1 only) in the Special Function Option, but not both.

If either option has been installed at the factory (see Factory Set-Up Information Sheet) and process conditions exist to activate the alarm, the "Auxiliary Alarm On" LED will light and corresponding alarm relay will be energized (after set delay time).

Controller

Controller output will continuously modulate (when in automatic) its output to maintain process at setpoint (internal or external).

*Note: The interval clock for AUTO-zero and AUTO-purge cycles is initiated when the VEL-trol II's power switch is turned on. The time intervals preset in User Setup menu will then start their timing sequence.

To reset the interval clock, turn power off for a minimum of 10 seconds, then turn power back on. Interval clock will then initiate at time zero.

Changing the interval selection in User Setup does not reset time clock.

5.4 – CONFIGURATION

The VEL-trol II's onboard microprocessor controls Configuration: Operating parameter selection; input/output activation and scaling, display scaling, and transducer calibration.

The customer can verify configuration and change certain parameters (within defined ranges) by entering the VEL-trol II's Configuration mode. This is accomplished using the four pushbuttons located on the VEL-trol II's top cover.

The type (i.e., 4-20mA, 0-5V, 0-10V) of available outputs can also be changed by jumper selections on I/O Board (see Section 4.6).

To gain access to the programming pushbuttons and jumper strip, remove two 10-32 screws on front cover and pull the cover straight up and swing to the right.

CAUTION: With cover removed, ESD (electrostatic discharge) precautions should be observed at all times to protect sensitive components.

Refer to Figure 5.1 for location of pushbuttons: **UP**, **DN**, **ESC**, and **ENT** for location of jumpers.

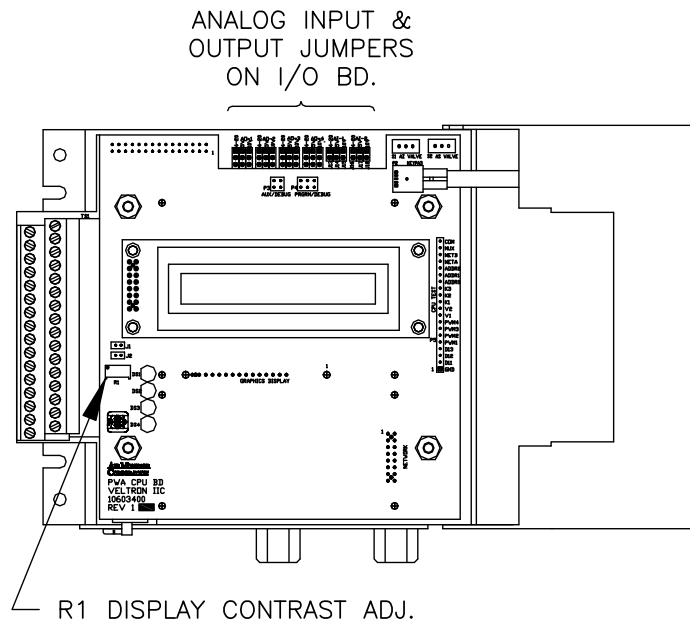

Figure 5.1

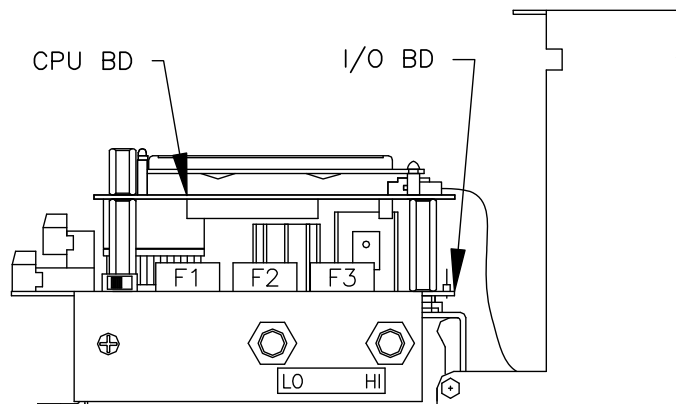

Figure 5.2

5.5 – PUSHBUTTON DEFINITION

In addition to Configuration programming, pushbuttons can be used for certain functions when in the *Normal* operation mode. The following list describes the pushbutton function when in the *Normal* operation mode and in the Operator Setup (programming).

When in Normal Operation Mode.

- ESC + ENT** Activates the Operator Setup menu.
- ESC + UP** Displays a list of Manual Actions available on the top line of the display. Use **UP** or **DN** to scroll through selections.
- UP + DN** Displays software Version, W.O. #, S/N, and ID.

The following list describes all possible actions. Those available depend on installed options.

- Turn On AutoZero Vlv Output not held.
- Perform Auto-Zero Output held.
- Perform Auto-Purge Output held.

When in Operator Setup.

- UP or DN** Use to scroll to the desired Main Menu item.
Use to scroll to the value or mode within a Parameter.
- ENT** Enters user into specific selection sub-menu from Main Menu Selection.
Displays current setting of selected Parameter.
Enters the selected value or mode into memory.
- ESC** Use to exit Main Menu selection to avoid scrolling to "Return to MAIN MENU".

The following pushbutton combinations can be used to more quickly set user selected values (i.e. process minimum and maximum, K-factor, Scaling Values, Characterization Values, etc.).

- UP* + ESC** Increase the second column digit.
- DN* + ESC** Decrease the second column digit.
- UP* + DN** Increase the third column digit.
- DN* + UP** Decrease the third column digit.
- UP* + ESC and DN** Increase the fourth column digit.
- DN* + ESC and UP** Decrease the fourth column digit.

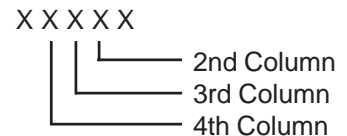

*Must be pressed and held before other button(s) are pressed.

NOTE
 Pushbuttons are momentary type and should be quickly pressed and released to initiate desired change, unless otherwise instructed to press and hold.

5.6 – CONFIGURATION PROGRAMMING

Note: User selectable parameters are limited to standard features and those available for options purchased and installed at the factory. The following will detail all user parameters, which may or may not be available on your unit.

With power ON and initialization complete (see Section 5.2), simultaneously press **ESC** and **ENT**, and display will indicate:

OPERATOR SETUP

Pressing **ENT** again will enter the user into the Main Menu of configuration programming. The display will indicate:

Operator Password
Selection

Refer to next page for Main Menu Selections.

5.6 – CONFIGURATION PROGRAMMING (con't)

By using **UP** and **DN**, the user can scroll through the following selections:

MAIN MENU SELECTION	DESCRIPTION
Operator Password Selection	Allows for the selection of a numeric password needed to gain further access to menu items. Also allows for the password to be bypassed.
Transmitter Scaling & Configuration	Allows for the configuration of process variable such as: Square root, process type, process minimum/ maximum/ units, duct area, and percent lockdown. Also offers a Flow/ D.P. calculator that allows user to calculate maximum flow or differential pressure based on entered variables.
Low Pass Filter Selection	Selects amount of filtering applied to transducer output.
AUTO-zero Configuration	Turns AUTO-zero function ON or OFF, and selects interval.
AUTO-purge Configuration	Turns AUTO-purge function ON or OFF, and selects internal/external activation, interval, purge duration, after purge time.
AUTO-calibration	Not installed with VEL-trol II.
Alarm Configuration	Turns alarm function ON or OFF, select Alarm Type, High and Low Setpoints, Deadband selection, and Alarm Delay.
Controller Configuration	Allows for the selection of the following Controller Parameters: Operation; Action; Internal Setpoint; Minimum and Maximum Output; Tuning; Manual Output Value; and, Soft Start Option.
Special Function Configuration	Turns Special Function ON or OFF, select from the following special functions: % Deviation; Summed Flow; Averaged Flow; Delta: Internal-External; Delta: External-Internal; Low Select; High Select; and Setup parameters specific to Special Function selected.
K-Factor Configuration	Turns K-Factor ON or OFF, and allows for the calculation or selection of gain and bias values.
Display Configuration	Allows for the configuration of Display Parameter and Filter.
Analog Output Configuration	Allows for the selection of Analog Output 3 and 4 parameters.
Transducer Span Selection	Allows for displaying the transducer's natural span and operating span.
Transmitter Input Calibration	Allows for the zeroing and spanning of transmitter analog Inputs.
Transmitter Output Calibration	Allows for the zeroing and spanning of transmitter analog Outputs.
Power Supply Calibration	Allows for adjustment of power supply voltage.
Transducer Characterization Selection	Allows transducer characterization data to be entered when transducer is replaced.
Network Configuration	Turns the Network ON or OFF, selection of input source.
Menu Inactivity Timeout Selection	Allows for the selection a time after which the unit returns to normal operation if no activity in the Operator Menu.
Exit Operator Setup	Returns display to <i>Normal</i> operation.

5.6 – CONFIGURATION PROGRAMMING (con't)

At any time while in the Main Menu, User can return to *Normal* operation mode by pressing **ESC** or scrolling to:



and pressing **ENT**.

Once the desired Selection is displayed, its sub-menu can be entered by pressing **ENT**.

To better understand the process of Configuration Programming, arrows with pushbutton designations have been included on the following flow chart of AUTO-zero Configuration. This will aid in the navigation of the Configuration Programming Process.

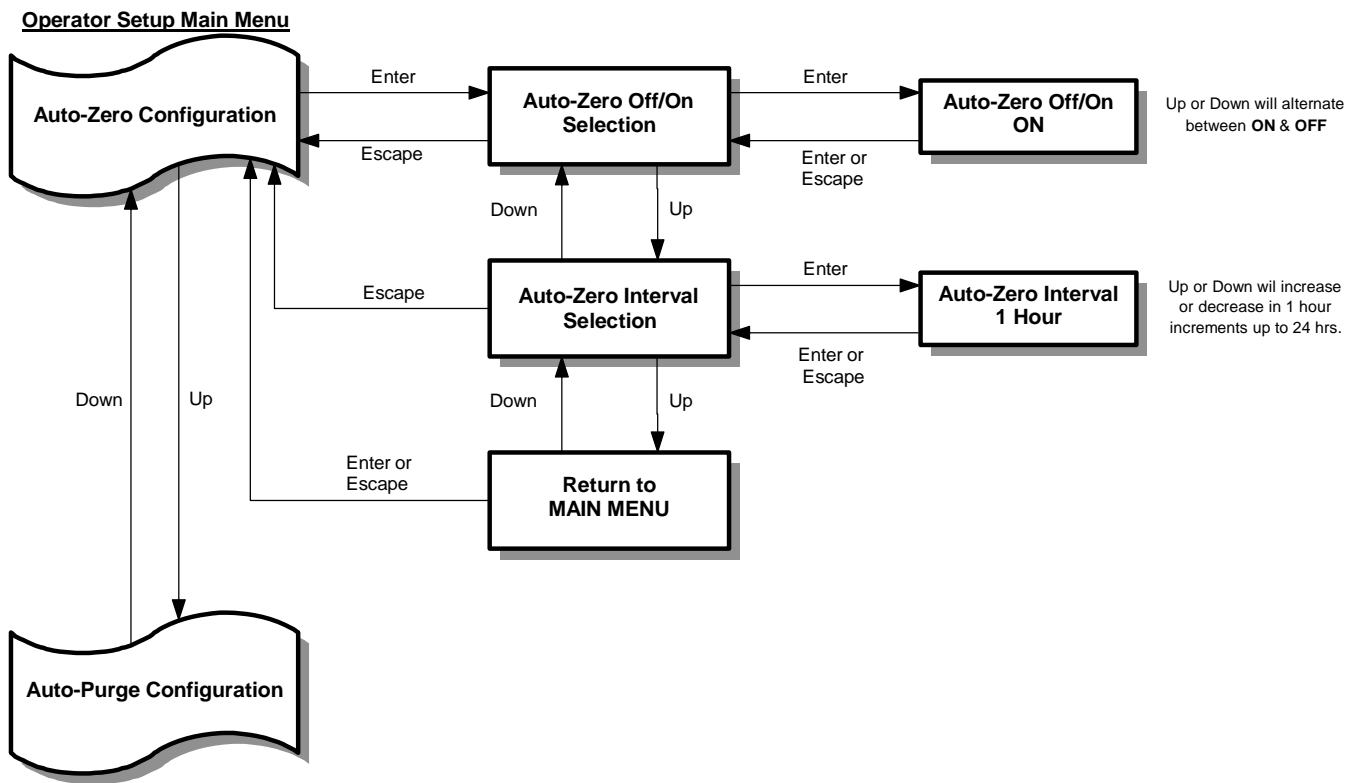

This example of navigation is similar for all Main Menu selections.

Note: All selections that are available for further configuration programming will have an "arrow" symbol displayed in the right side of the display field. Those that are not available for further configuration programming will not have the "arrow" symbol displayed and will display Not Installed beneath the selection description. Example:

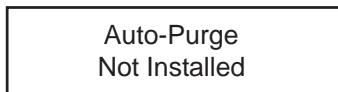

The remainder of this Section details steps to verify or change Configuration Programming of all Main Menu Selections.

5.7 – OPERATOR PASSWORD SELECTION

User can select numeric password or bypass password requirement. Note: Units are shipped from the Factory with the password set to 1,111 and bypassed.

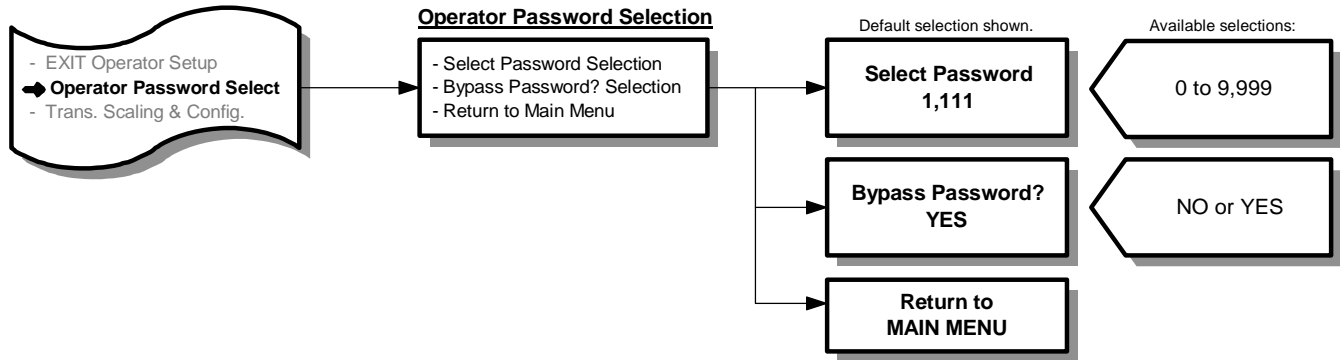

1. While in Main Menu, use **UP** or **DN** to scroll to:

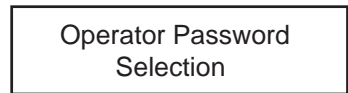

2. Press **ENT** to enter Operator Password Selection menu. Display will indicate:

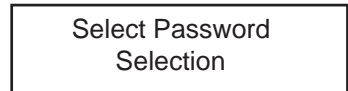

3. Press **ENT** and display will indicate current password (1,111).

4. Use **UP** or **DN** to change password. Once desired password is displayed, press **ENT**. New password will be stored in memory and display will return to Operator Password Selection menu as in Step 2.

Note: If user desired not to change the password and return to Operator Password Selection menu, press **ESC**. Unit will remain programmed as it was originally.

5. Use **UP** or **DN** to select remaining parameters to be changed.

6. Follow Step 4 to make any changes to parameters.

7. To return to Main Menu, select Return to MAIN MENU in Standard Display Configuration menu and press **ENT**.

5.8 – TRANSMITTER SCALING & CONFIGURATION

This Main Menu selection is where all application specific data is entered to configure the VEL-trol II for a unique application. Data is entered under sub-menu, Process Configuration, and includes as applicable: Process Type, Process Minimum/Maximum, Process Type, Duct Area/Units, etc.

Note: Factory has entered data in this section based on customer supplied information. Data can be reviewed and verified by scrolling through the individual menu items or reviewing the Factory Set-Up Information sheet provided with the unit. Review this information **before** making any changes, as they can have a significant effect on the operation of the VEL-trol II.

Under a second sub-menu, Calculator for Max Diff. Pres. or Flow, user can calculate either maximum flow or maximum differential pressure (D.P.) when operating parameters have changed. Each sub-menu will be addressed separately.

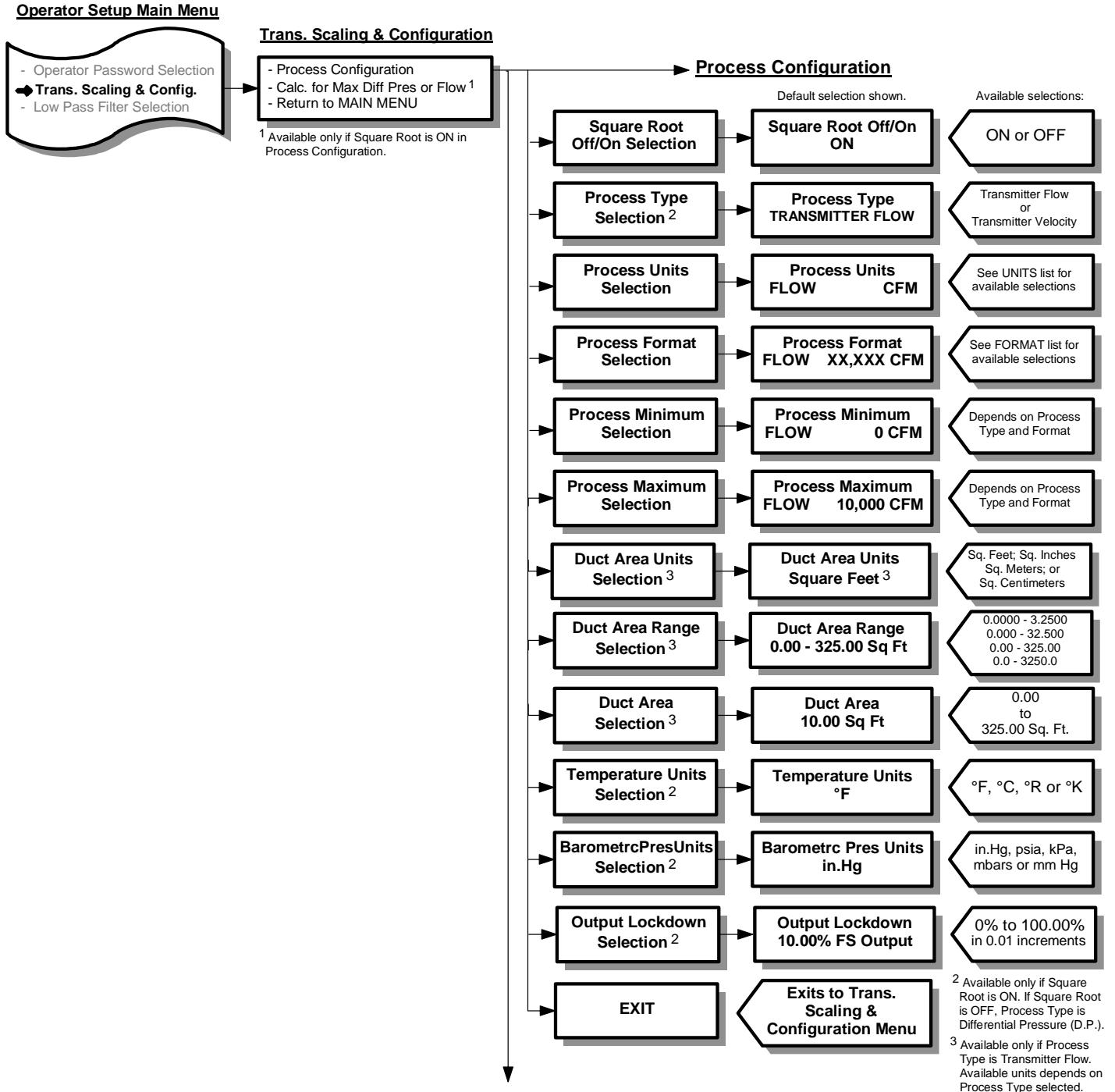

5.8 – TRANSMITTER SCALING & CONFIGURATION

1. While in Main Menu, use **UP** or **DN** to scroll to:

Transmitter Scaling and Configuration
--

2. Press **ENT** to enter Transmitter Scaling & Configuration menu. Display will indicate:

Process Configuration

3. Press **ENT** to enter the Process Configuration sub-menu. Display will indicate:

Square Root Off/On Selection

4. Press **ENT** and display will indicate current setting of Square Root (OFF or ON).

Note: If the measured process is flow, Square Root must be ON. If Square Root is OFF, the process will be assumed to be differential pressure (D.P.).

5. Use **UP** or **DN** to change setting. Once desired setting is displayed, press **ENT**, new setting will be stored in memory and display will return to Process Configuration sub-menu as in Step 3.

Note: If user desires not to change the setting and return to the Process Configuration sub-menu, press **ESC**. Unit will remain programmed as it was originally.

6. Use **UP** or **DN** to select remaining parameters to be changed within the Process Configuration sub-menu.

See the follow Units Lists for the available Process Units selections for the appropriate Process Type.
See the following Format List for the available Process Format selections.

7. Follow Step 5 to make any changes to parameters.

8. To return to the Transmitter Scaling & Configuration menu, select EXIT in the Process Configuration sub-menu and press **ENT**.

Note: If Process Minimum is selected to be a value greater than zero (0), Transmitter Output 1 will not increase until the actual process exceeds this selected value. This is known as "Zero Suppression".

Zero Suppression (Process Minimum) can be set up to 60% of the Process Maximum selected.

Display of process is not affected by this selection, and will indicate the actual process value.

If Analog Output 3 and/or 4 is selected to represent TRANSMITTER, it will act the same as Transmitter Output 1.

5.8 – TRANSMITTER SCALING & CONFIGURATION (con't)

UNITS LIST for Process Type – Velocity	
UNIT OF MEASUREMENT	DISPLAY
feet per second	FPS
feet per minute	FPM
feet per hour	FPH
meters per second	m/s
meters per minute	m/m
meters per hour	m/hr
Actual feet per second	AFPS
Actual feet per minute	AFPM
Actual feet per hour	AFPH
Actual meters per second	Am/s
Actual meters per minute	Am/m
Actual meters per hour	Am/hr
Standard feet per second	SFPS
Standard feet per minute	SFPM
Standard feet per hour	SFPH
Standard meters per second	Sm/s
Standard meters per minute	Sm/m
Standard meters per hour	Sm/hr
Normal meters per second	Nm/s
Normal meters per minute	Nm/m
Normal meters per hour	Nm/hr
Percent	%

5.8 – TRANSMITTER SCALING & CONFIGURATION (con't)

UNITS LIST for Process Type – Flow

cubic feet per second	CFS
cubic feet per minute	CFM
cubic feet per hour	CFH
liters per second	l/s
liters per minute	l/m
liters per hour	l/hr
cubic meters per second	m ³ /s
cubic meters per minute	m ³ /m
cubic meters per hour	m ³ /hr
Actual cubic feet per second	ACFS
Actual cubic feet per minute	ACFM
Actual cubic feet per hour	ACFH
Actual liters per second	Al/s
Actual liters per minute	Al/m
Actual liters per hour	Al/hr
Actual cubic meters per second	Am ³ /s
Actual cubic meters per minute	Am ³ /m
Actual cubic meters per hour	Am ³ /h
Standard cubic feet per second	SCFS
Standard cubic feet per minute	SCFM
Standard cubic feet per hour	SCFH
Standard liters per second	Sl/s
Standard liters per minute	Sl/m
Standard liters per hour	Sl/hr
Standard cubic meters per second	Sm ³ /s
Standard cubic meters per minute	Sm ³ /m
Standard cubic meters per hour	Sm ³ /h
Normal liters per second	Nl/s
Normal liters per minute	Nl/m
Normal liters per hour	Nl/hr
Normal cubic meters per second	Nm ³ /s
Normal cubic meters per minute	Nm ³ /m
Normal cubic meters per hour	Nm ³ /h
pounds per second	lb/s
pounds per minute	lb/m
pounds per hour	lb/hr
Tons per hour	T/hr
Tons per day	T/day
grams per second	gm/s
kilograms per second	kg/s
kilograms per minute	kg/m
kilograms per hour	kg/hr
Percent	%

5.8 – TRANSMITTER SCALING & CONFIGURATION (con't)

UNITS LIST for Process Type – Differential Pressure	
UNIT OF MEASUREMENT	DISPLAY
inches of water column	in.WC
inches of mercury	in.Hg
pounds per square inch, gauge	psig
Pascals	Pa
kilo Pascals	kPa
bars	bars
millibars	mbars
millimeter of water column	mm WC
millimeter of mercury	mm Hg
kilograms per square meter	kg/m ²
Percent	%

FORMAT LIST	
.0XXXXX	(–.025000 to .025000)
0.XXXXX	(–0.25000 to 0.25000)
X.XXXX	(–2.5000 to 2.5000)
XX.XXX	(–25.000 to 25.000)
XXX.XX	(–250.00 to 250.00)
X,XXX.X	(–2,500.0 to 2,500.0)
XX,XXX	(–25,000 to 25,000)
XXX,XX0	(–250,000 to 250,000)
XXXX,X00	(–2500,000 to 2500,000)
XXXX,000	(–9999,000 to 9999,000)

5.8 – TRANSMITTER SCALING & CONFIGURATION (con't)

User should not need to use the following Calculator unless:

- a. Process parameters have changed and new Differential Pressure or Flow values are needed.
- b. Mid-point operating Differential Pressure or Flow values are wanted.
- c. It is desired to implement a single-point density compensation for process temperature and/or absolute pressure that is significantly different than standard conditions (68°F and 29.92" Hg).

Values entered in this section will have no effect on normal operation unless user enters YES in the Update Flow/ Operating Span Value menu item (see below).

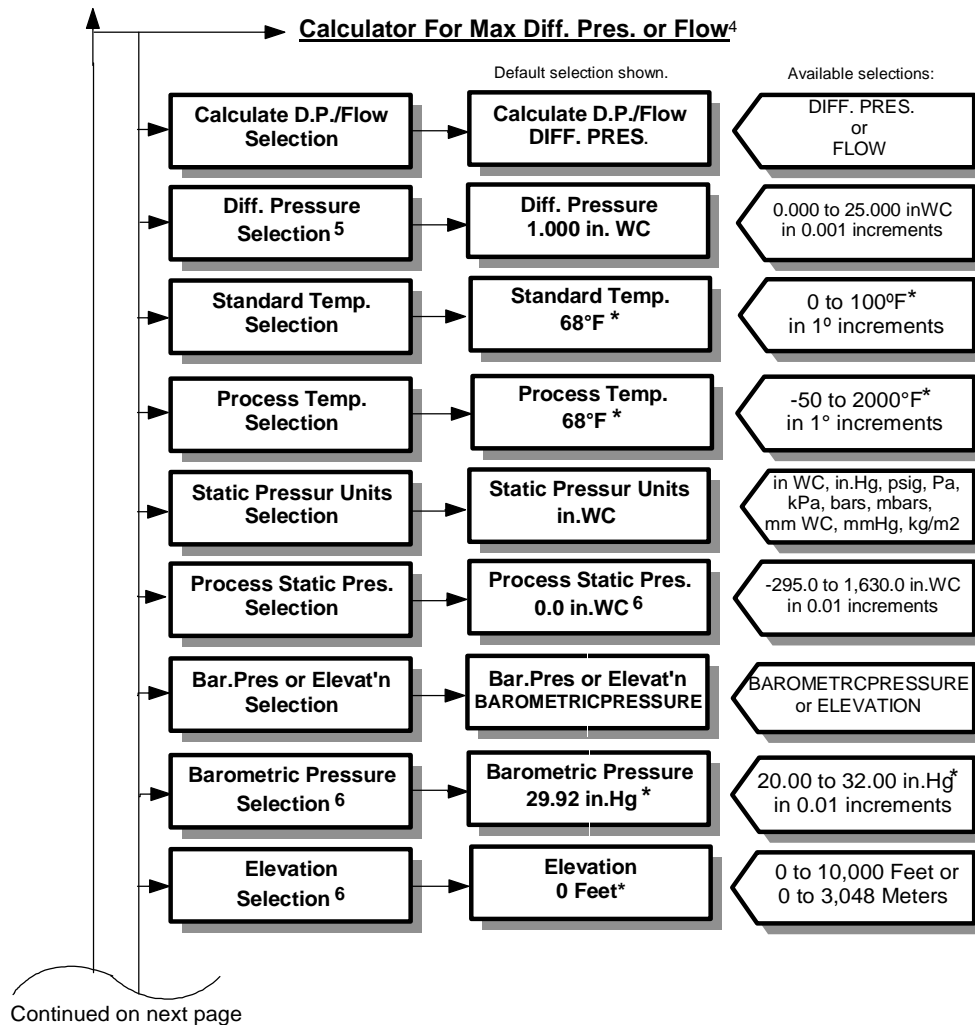

5.8 – TRANSMITTER SCALING & CONFIGURATION (con't)

Continued from next page

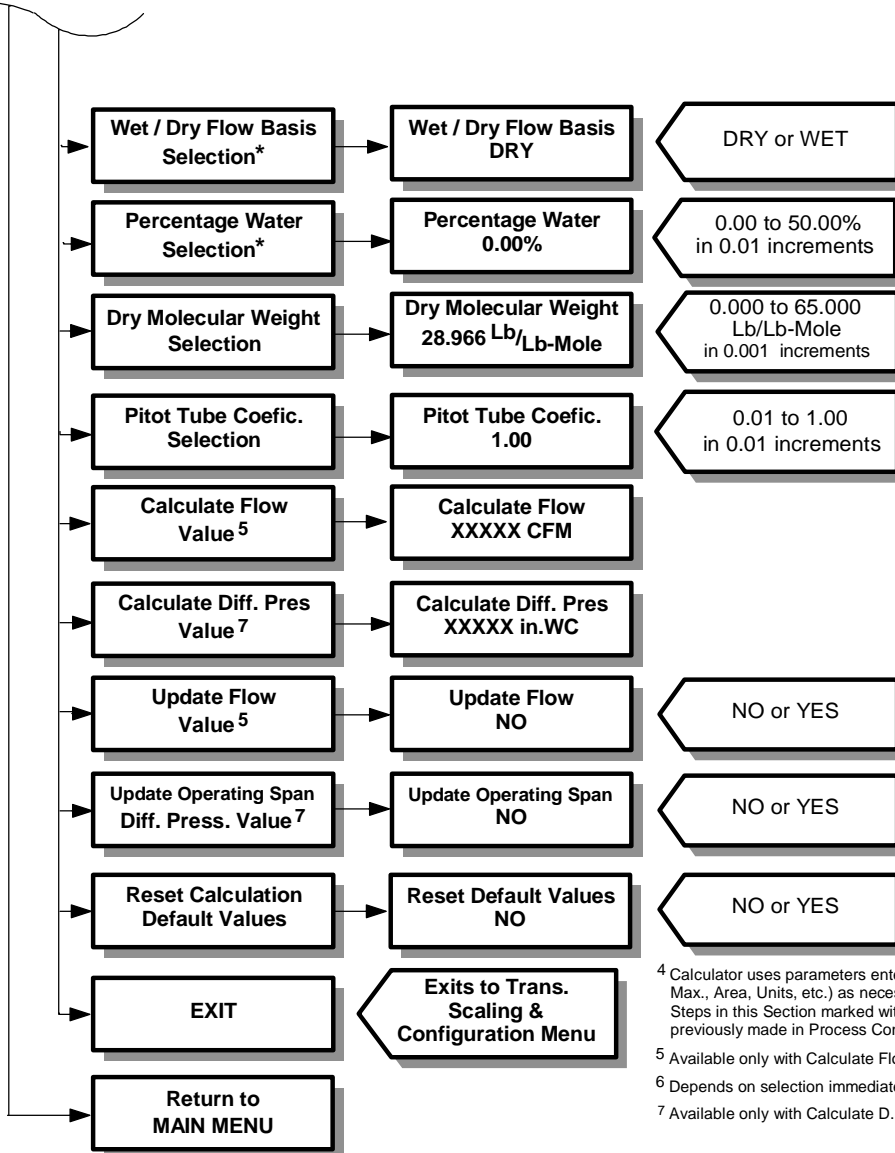

⁴ Calculator uses parameters entered in Process Configuration (ie.Type, Max., Area, Units, etc.) as necessary to perform calculation. Steps in this Section marked with * indicate values or choices previously made in Process Configuration.

⁵ Available only with Calculate Flow.

⁶ Depends on selection immediately above.

⁷ Available only with Calculate D.P.

5.8 – TRANSMITTER SCALING & CONFIGURATION (con't)

As an example of how to utilize the calculator, the following shows how to change the Operating Span if the process temperature is 150°F.

9. While in Transmitter Scaling & Configuration menu, use **UP** or **DN** to scroll to:

Calculator for Max
Diff. Pres. or Flow

10. Press **ENT** to enter the Calculator for Max Diff. Pres. or Flow sub-menu.
Display will indicate:

Calculate D.P./Flow
Selection

11. Press **ENT** and display will indicate:

Calculate D.P./Flow
DIFF. PRES.

12. Press **ENT** and **UP** twice and display will indicate:

Process Temperature
Selection

13. Press **ENT** and use **UP** button until temperature reads 150°F.

14. Press **ENT** and scroll to:

Calculate Diff. Pres
Value

15. Press **ENT** and a new value for Differential Pressure will be displayed.

16. Press **ENT** and **UP** and display will read:

Update Operating Span
Diff. Pres. Value

17. Press **ENT**, scroll to YES and press **ENT**, display will return to that shown in Step 16, and new operating span will be stored in memory.

Note: If during this step, display indicated CAL. SPAN NOT UPDATED NAT. SPAN TOO LOW or HIGH, new span is less than 40% or greater than 100% of the natural span of the transducer installed. User should contact Factory for further assistance (see section 10.0).

18. To return to the Transmitter Scaling & Configuration menu, select EXIT in the Calculator for Max Diff. Pres. or Flow sub-menu and press **ENT**.

19. To return to the Main Menu, select Return to MAIN MENU in the Transmitter Scaling & Configuration menu and press **ENT**.

5.9 – LOW PASS FILTER SELECTION

User can select level of filtering applied to the transducer output*. Levels are 0 to 8, with 0 representing no filtering, 1 representing minimal filtering (0.5 sec time constant), and 8 representing maximum filtering (64 sec time constant).

*This filtering affects all subsequent outputs, displays, special function, alarms, etc., that utilize the transducer output.

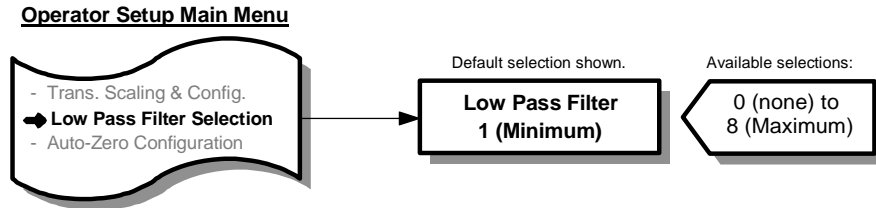

1. While in Main Menu, use **UP** or **DN** to scroll to:

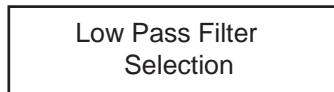

2. Press **ENT** and display indicates current setting of Low Pass Filter; 0 (none) to 8 (Maximum).

3. Use **UP** or **DN** to change setting. Once desired setting is displayed, press **ENT** and new setting will be stored in memory and display will return to Main Menu.

Note: If user desires not to change the setting and return to Main Menu, press **ESC**. Unit will remain programmed as it was originally.

5.10 – AUTO-zero CONFIGURATION

User can turn AUTO-zero function ON or OFF, and select activation interval.

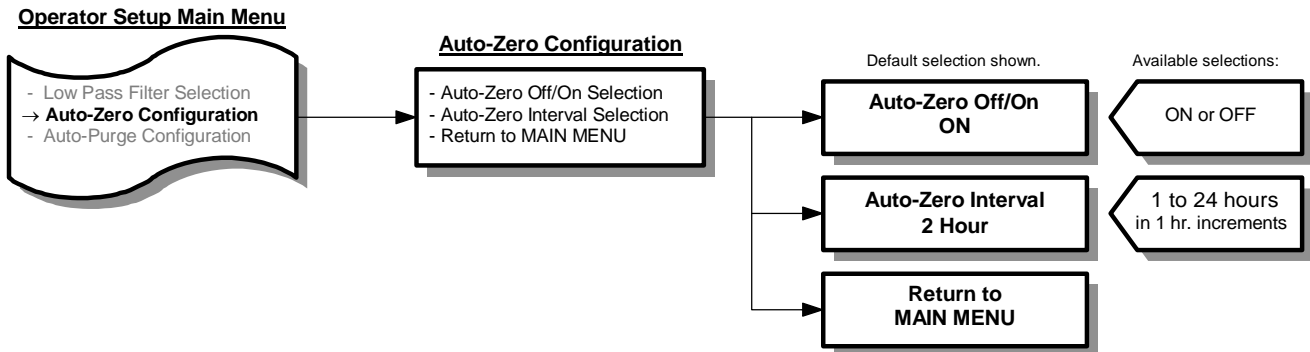

1. While in Main Menu, use **UP** or **DN** to scroll to:

Auto-Zero Configuration
2. Press **ENT** to enter AUTO-zero Configuration menu. Display will indicate:

Auto-Zero Off/On Selection
3. Press **ENT** and display will indicate current setting of AUTO-zero (OFF or ON).
4. Use **UP** or **DN** to change setting. Once desired setting is displayed, press **ENT** and new setting will be stored in memory and display will return to AUTO-zero Configuration menu as in Step 2.

Note: If user desires not to change the setting and return to AUTO-zero Configuration menu, press **ESC**. Unit will remain programmed as it was originally.

5. Use **UP** or **DN** to select remaining parameters to be changed.
6. Follow Step 4 to make any changes to parameters.
7. To return to Main Menu, select Return to MAIN MENU in AUTO-zero Configuration menu and press **ENT**.

5.11 – AUTO-purge CONFIGURATION

User can turn AUTO-purge function ON or OFF, select method of activation, activation interval, purge duration, and after purge duration.

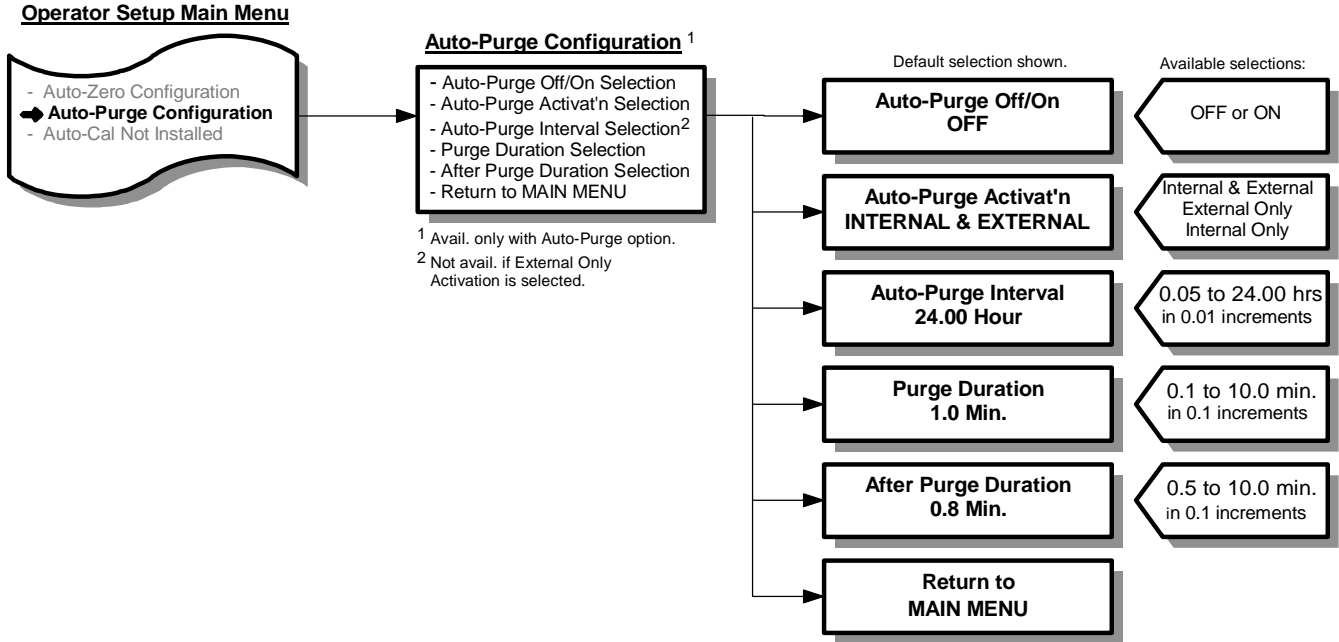

1. While in Main Menu, use **UP** or **DN** to scroll to:

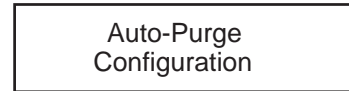

2. Press **ENT** to enter AUTO-purge Configuration menu. Display will indicate:

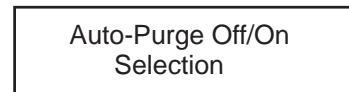

3. Press **ENT** and display will indicate current setting of AUTO-purge (OFF or ON).

4. Use **UP** or **DN** to change setting. Once desired setting is displayed, press **ENT**. New setting will be stored in memory and display will return to Auto-purge Configuration menu as in Step 2.

Note: If user desires not to change the setting and return to AUTO-purge Configuration menu, press **ESC**. Unit will remain programmed as it was originally.

5. Use **UP** or **DN** to select remaining parameters to be changed.

6. Follow Step 4 to make any changes to parameters.

7. To return to Main Menu, select Return to MAIN MENU in AUTO-purge Configuration menu and press **ENT**.

5.12 – AUTO-calibration CONFIGURATION

Operator Setup Main Menu

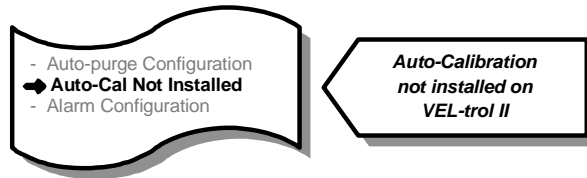

5.13 – ALARM CONFIGURATION

User can turn each Alarm ON or OFF, select type of alarm (See Section 3.6 – Features for description of the different Alarm types), and set the following values:

Alarm 1 Setpoint (this is Low, Low1, or High1 depending on Alarm Type): Selected value of transmitter span, below (for Low and Low1) or above (for High 1) which an alarm condition will exist. Value is selected in same units as transmitter format.

Alarm 2 Setpoint (this is High, Low2, or High2, depending on Alarm Type): Selected value of transmitter span below (for Low2) or above (for High and High2) which an alarm condition will exist. Value is selected in same units as transmitter format.

Alarm Deadband: Value that transmitter signal has to reach above (for Low, Low1, or Low2) or below (for High, High1, or High2) before an activated alarm will reset. Value is selected in same units as transmitter span.

Alarm Delay: Time between an alarm condition existing and alarm activation. Adjustable between 0.0 and 10.0 minutes in 0.1 minute increments.

Operator Setup Main Menu



Alarm Configuration ¹

- Alarm 1 Off/On Selection
- Alarm 2 Off/On Selection
- Alarm Type Selection
- Alarm 1, *Low*² Setpt Selection
- Alarm 2, *High*³ Setpt Selection
- Alarm 1 Dead Band Selection
- Alarm 2 Dead Band Selection
- Alarm 1 Delay Selection
- Alarm 2 Delay Selection
- Return to MAIN MENU

¹ Available only with Alarm option.
² *Low*, *Low1*, or *High1* depending on Alarm Type Selected.
³ *High*, *Low2*, or *High2* depending on Alarm Type Selected.

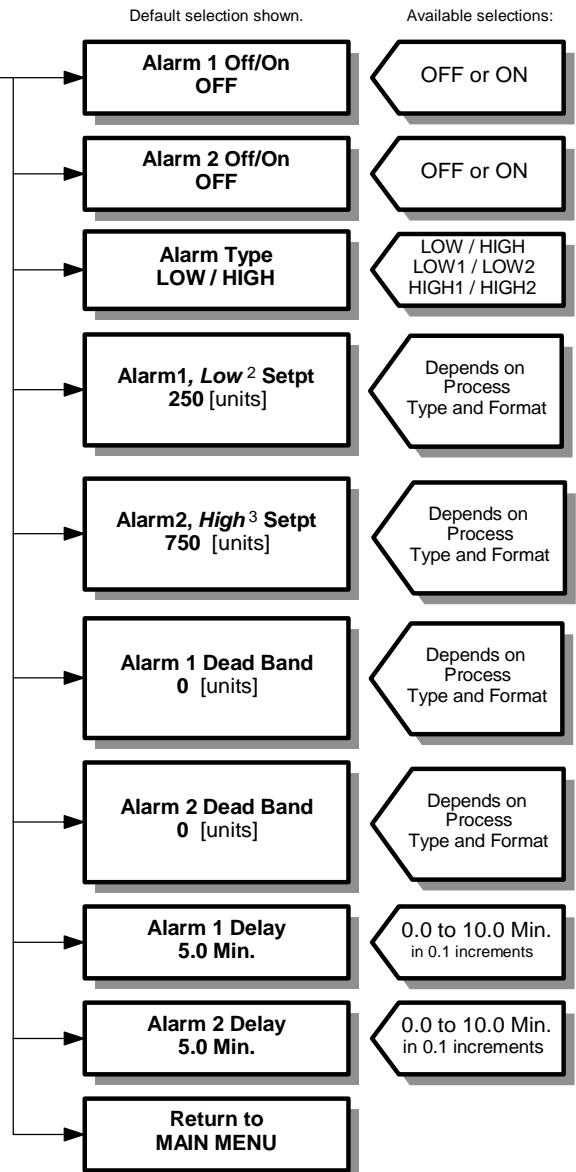

5.13 – ALARM CONFIGURATION (con't)

1. While in Main Menu, use **UP** or **DN** to scroll to:

Alarm
Configuration

2. Press **ENT** to enter Alarm Configuration menu. Display will indicate:

Alarm 1 Off/On
Selection

3. Press **ENT** and display will indicate current setting of Alarm 1 (OFF or ON).
4. Use **UP** or **DN** to change setting. Once desired setting is displayed, press **ENT**. New setting will be stored in memory and display will return to Alarm Configuration menu as in Step 2.

Note: If user desires not to change the setting and return to Alarm Configuration menu, press **ESC**. Unit will remain programmed as it was originally.

5. Use **UP** or **DN** to select remaining parameters to be changed.
6. Follow Step 4 to make any changes to parameters.
7. To return to Main Menu, select Return to MAIN MENU in Alarm Configuration menu and press **ENT**.

5.14 – CONTROLLER CONFIGURATION

User can customize the various controller parameters to their specific application.

Operation Selection. Select Automatic or Manual operation. In Automatic, controller output modulates as necessary to maintain process at setpoint. In Manual, controller output is maintained at a user selectable value (percentage).

Output Manual Value. A percentage of controller output (0-100%) that is maintained when manual operation is selected (see above).

Action Selection. Select direct or reverse controller action. Direct action, increase controller output when process is higher than setpoint. Reverse action, decreases controller output when process is higher than setpoint.

Soft Start Selection. This feature requires an external dry contact input from user. See Section 4.5 for more details of this input. This input usually corresponds to system start (i.e. dry contact closure when fan is started). When the dry contact closure is received, the controller output will begin to bring the process up from minimum to setpoint in a gradual manner. When the dry contact is opened, the controller output will bring the process down to a minimum and remain until the dry contact closure is received. This feature precludes the starting of a system under full load.

If Soft Start is enabled, and external dry contact at terminals #12 and 13 is open, "System Start Off" will be displayed where the setpoint is normally displayed.

Special Function Control. This feature allows for selecting the Special Function (see Section 5.14) as the controlled variable. When ON, the controller output will modulate to control the Special Function result to the desired setpoint. This feature is available only if Special Function is installed.

Setpoint Selection. Selected value of transmitter (process) span which controller will maintain by modulating its output. Value selected is displayed in same units as transmitter format.

Proportional Band Gain. Control mode in which controller output is proportional to proportional gain times the input error. Proportional Gain is a dimensionless number between 0.10 and 10.00, adjustable in 0.01 increments. Factory default setting of this variable is 1.00. Increasing the gain will speed up the controller's response to change.

Integral. Control mode in which controller output is proportional to time integral of input error, and as long as error exists in reference to time, controller output will increase or decrease as necessary to bring error to zero. Time constant is expressed in seconds. Range is 0.0 to 60.0 seconds adjustable in 0.1 increments. Factory default setting of this variable is 10.0 seconds. Decreasing the time constant will speed up the controller's response to change.

Inverse Derivative. Control mode in which controller's proportional mode output response is delayed by inverse derivative function. This special feature is very useful in controlling fast process such as flow. Time constant is expressed in minutes, Range is 0.0 to 10.0 minutes, adjustable in 0.1 increments. Factory default setting of this variable is 1.0 minute. Decreasing the time constant will speed up the controller's response to change.

Note: Generally, a controller cycling several times before settling at setpoint indicates an under-damped system. Slowing of the controller's speed of response is recommended. A controller taking excessive time to reach its setpoint without overshooting indicates an over-damped system. Speed up the controller's response in this case. An optimally tuned (critically damped) system will generally have one overshoot and one undershoot prior to settling at setpoint.

Null Dead Band. Holds controller output constant when controller error (difference between process signal and setpoint) is less than or equal to the selected Dead Band. Dead Band is entered as a percentage of setpoint and is applied as the equivalent process value above and below the setpoint. Factory default setting is 0.00%.

This feature helps stabilize systems where a small change in controller output yields a large change in the process.

5.14 – CONTROLLER CONFIGURATION (con't)

Output Minimum Value. Select between 0.0% and 100.0% as the minimum value controller output will reach. This percentage output is applied to the final output (user selectable at 0-5V, 0-10V, or 4-20mA, see Section 4.6). This feature allows user to match controller output to actuators, VFD's, etc., that may require a minimum value different than the controller's standard 0V or 4mA.

Output Maximum Value. Select between 0.0% and 100.0% as the maximum value controller output will reach. This percentage output is applied to the final output (user selectable at 0-5V, 0-10V, or 4-20mA, see Section 4.6).

This feature allows user to match controller output to actuators, VFD's, etc., that may require a maximum value different than the controller's standard 5V, 10V or 20mA.

Operator Setup Main Menu

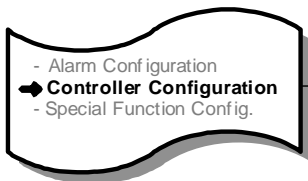

Controller Configuration

- Controller Operation Selection
- Output Manual Value Selection
- Controller Action Selection
- Controller Soft Start Selection
- Spec. Func. Control Selection¹
- Controller Setpoint Selection
- Prop. Band Gain
- Integral Time Constant Selection
- Inverse Derivative Time Selection
- Null Dead Band
- Output Minimum Value Selection
- Output Maximum Value Selection
- Return to Main Menu

¹ Available only if Special Function is ON.

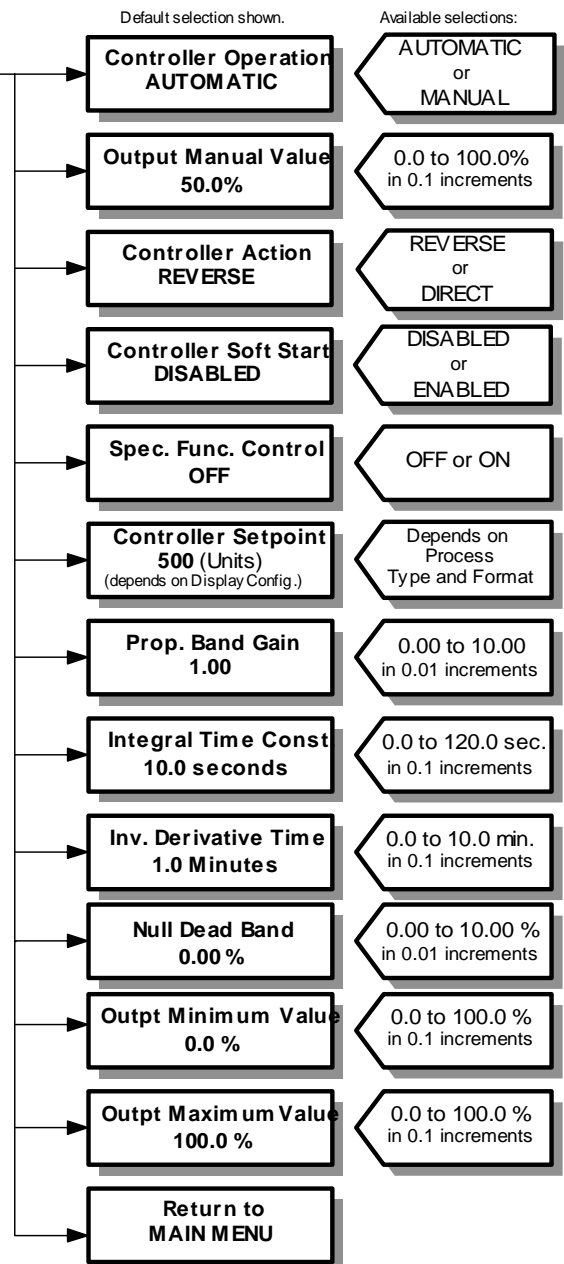

5.14 – CONTROLLER CONFIGURATION (con't)

1. While in Main Menu, use **UP** or **DN** to scroll to:

Controller Configuration

2. Press **ENT** to enter Controller Configuration menu. Display will indicate:

Controller Operation Selection

3. Press **ENT** and display will indicate current Controller Operation selection [AUTOMATIC or MANUAL].
4. Use **UP** or **DN** to change selection. Once desired setting is displayed, press **ENT**. New setting will be stored in memory and display will return to Controller Configuration menu as in Step 2.

Note: If user desires not to change the setting and return to Controller Configuration menu, press **ESC**. Unit will remain programmed as it was originally.

5. Use **UP** or **DN** to select remaining parameters to be changed.
6. Follow Step 4 to make any changes to parameters.
7. To return to Main Menu, select Return to MAIN MENU in Controller Configuration menu and press **ENT**.

5.15 – SPECIAL FUNCTION CONFIGURATION

User can turn Special Function ON or OFF, select type of function (See Section 3.7 – Features, for description of the different special functions), and set the following values:

External Input Maximum: This value represents the maximum value of the external input. This value is used if External Special Function Input is selected as a display parameter.

Percent Deviation Setpoint: (Note: Available only if Percent Deviation is selected as Function Type.) The percent difference between the transmitter signal and an external input that will cause an alarm condition when exceeded.

Alarm Deadband: (Note: Available only if Percent Deviation is selected as Function Type.) A percentage below the percent deviation setpoint which the deviation must reach to reset an activated alarm.

Alarm Delay: (Note: Available only if Percent Deviation is selected as Function Type.) Time between an alarm condition existing and alarm activation. Adjustable between 0.0 and 10.0 minutes in 0.1 minute increments.

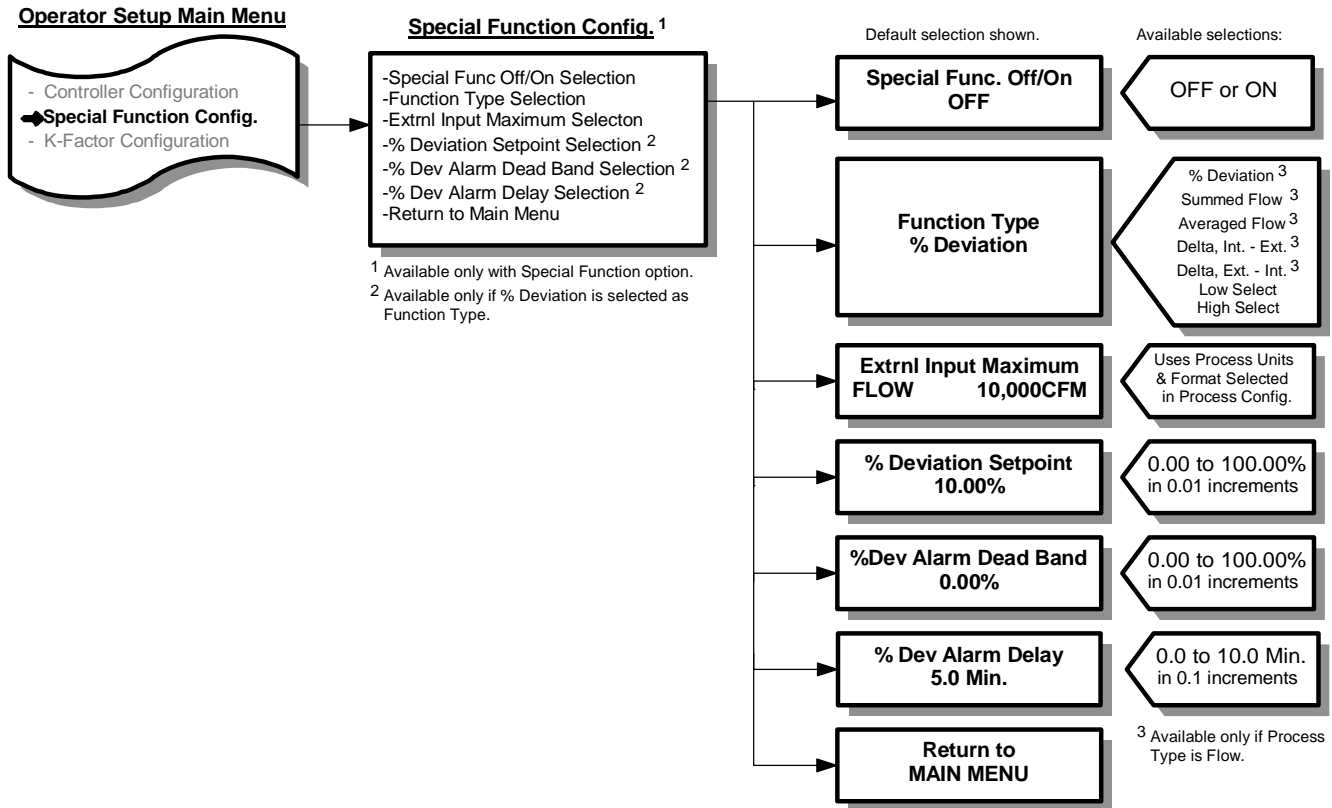

5.15 – SPECIAL FUNCTION CONFIGURATION (con't)

1. While in Main Menu, use **UP** or **DN** to scroll to:

Special Function
Configuration

2. Press **ENT** to enter Special Function Configuration menu. Display will indicate:

Special Func. Off/On
Selection

3. Press **ENT** and display will indicate current setting of Special Function (OFF or ON).
4. Use **UP** or **DN** to change setting. Once desired setting is displayed, press **ENT**. New setting will be stored in memory and display will return to Special Function Configuration menu as in Step 2.

Note: If user desires not to change the setting and return to Special Function Configuration menu, press **ESC**. Unit will remain programmed as it was originally.

5. Use **UP** or **DN** to select remaining parameters to be changed.
6. Follow Step 4 to make any changes to parameters.
7. To return to Main Menu, select Return to MAIN MENU in Special Function Configuration menu and press **ENT**.

5.16 – K-FACTOR CONFIGURATION

CAUTION: In the majority of applications, the use of a K-Factor is neither required nor desirable. Before using the K-Factor feature, contact the Service Department (see Section 10) to review the application and obtain assistance in determining the K-Factor gain and bias values.

User can turn K-Factor ON or OFF, select K-Factor, calculate a K-Factor Gain and Bias (or Exponent) from measured data or select a K-Factor Gain and Bias (or Exponent) value. Note: If K-Factor is ON, Process displays will have an asterisk (*) after the description (i.e. FLOW*).

Operator Setup Main Menu

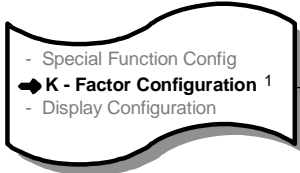

¹ Not available if Process Type is D.P. (see Transmitter Scaling & Config.)

K- Factor Configuration

- K - Factor Off/On Selection
- K - Factor Type Selection
- Calculate K-Factor? Selection ²
- Numb of Data Points Selection ³
- Measured Point 1 (2,3) Selection ³
- Reference Point 1 (2,3) Selection ³
- Perform Calculation ³
- Coefficient A (B,C,D,E,F,G) Selection ⁴
- K - Factor Exponent Selection ⁵
- K - Factor Gain Selection ⁵
- K - Factor Bias Selection ⁵
- Display Max D.P. ²
- Return to MAIN MENU

² Not available if K-Factor Type is Polynomial.

³ Available only if YES is selected in Calculate K-Factor? Measured refers to transmitter's indicated flow value. Reference refers to flow value obtained by traversing.

⁴ Available only if K-Factor Type is Polynomial.

⁵ Available only if NO is selected in Calculate K-Factor? and depends on Type of K-Factor.

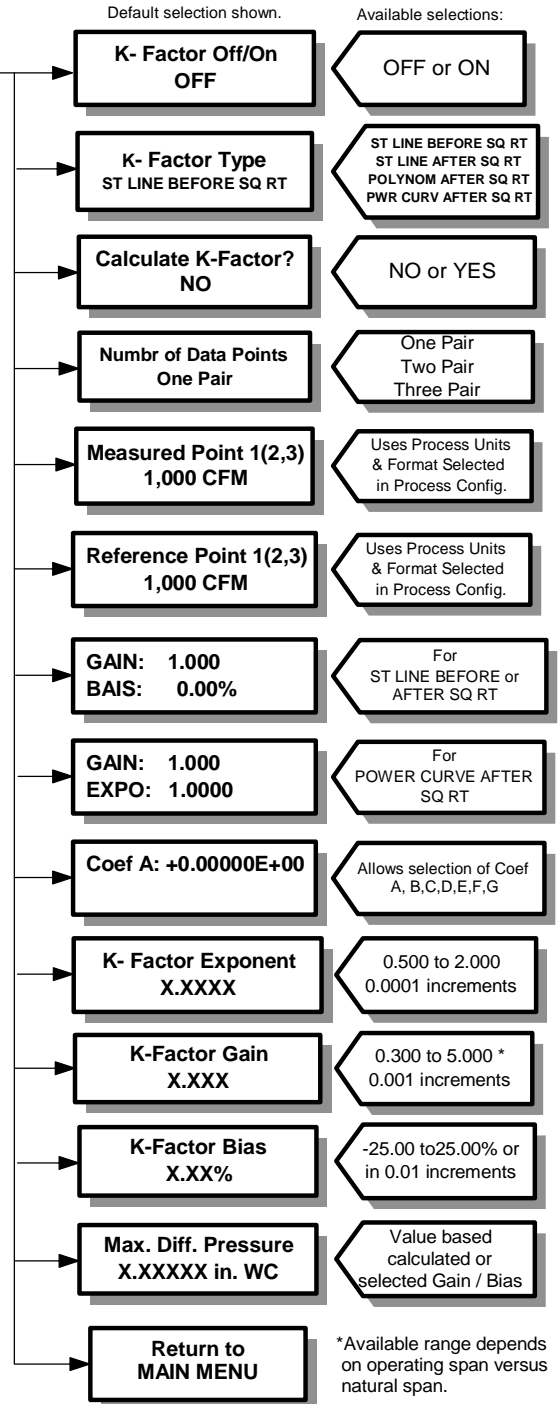

5.16 – K-FACTOR CONFIGURATION (con't)

1. While in Main Menu, use **UP** or **DN** to scroll to:

K-Factor Configuration

2. Press **ENT** to enter K-Factor Configuration menu. Display will indicate:

K-Factor Off/On Selection

3. Press **ENT** and display will indicate current setting of K-Factor (OFF or ON).
4. Use **UP** or **DN** to change setting. Once desired setting is displayed, press **ENT**. New setting will be stored in memory and display will return to K-Factor Configuration menu as in Step 2.

Note: If user desires not to change the setting and return to K-Factor Configuration menu, press **ESC**. Unit will remain programmed as it was originally.

5. Use **UP** or **DN** to select remaining parameters to be changed.
6. Follow Step 4 to make any changes to parameters.
7. To return to Main Menu, select Return to MAIN MENU in parameter menu and press **ENT**.

5.17 – STANDARD DISPLAY CONFIGURATION

User can select display parameter for Line 2 and level of filtering.

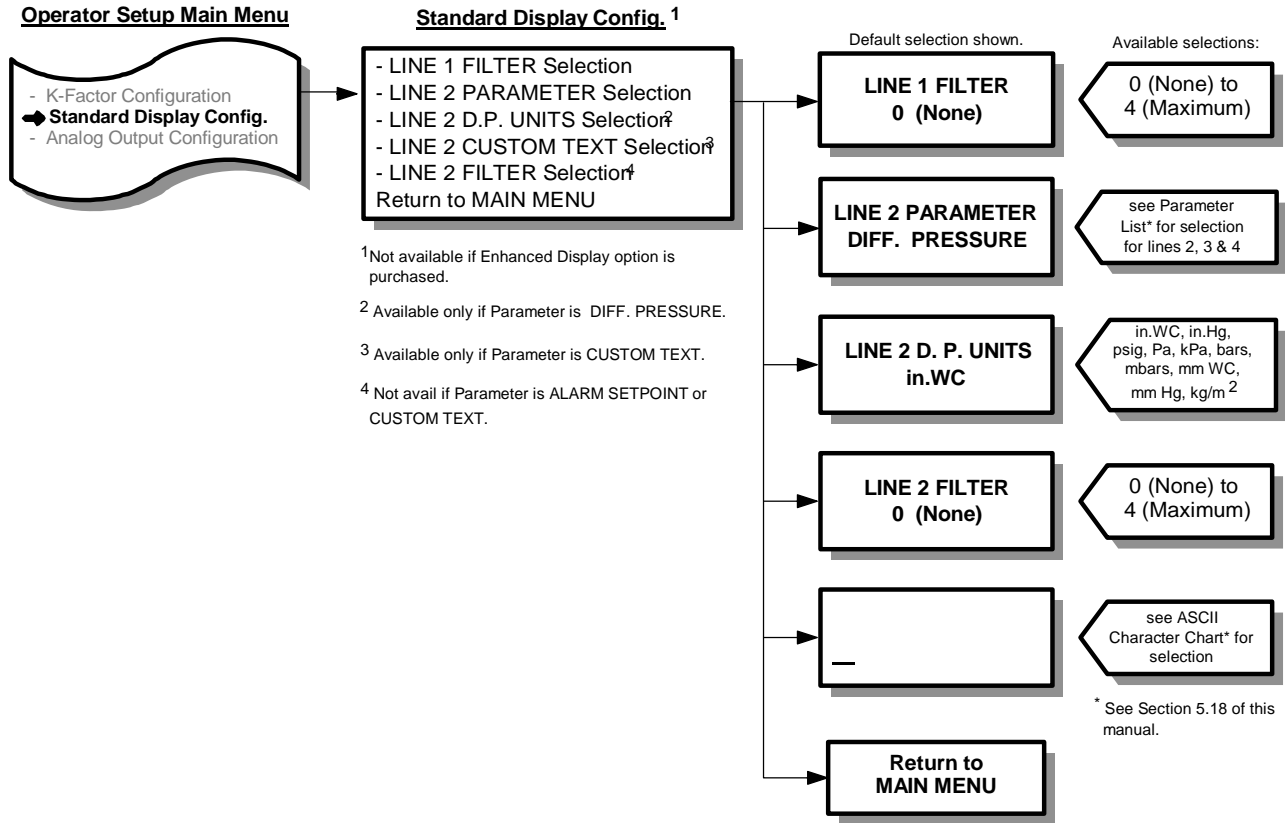

1. While in Main Menu, use **UP** or **DN** to scroll to:

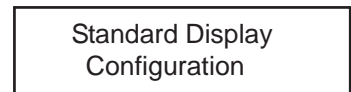

2. Press **ENT** to enter Standard Display Configuration menu. Display will indicate:



3. Press **ENT** and display will indicate current setting of the filter [0 (None), 1 (Minimum), 2, 3, or 4 (Maximum)].

4. Use **UP** or **DN** to change setting. Once desired setting is displayed, press **ENT**. New setting will be stored in memory and display will return to Standard Display Configuration menu as in Step 2.

Note: If user desires not to change the setting and return to Standard Display Configuration menu, press **ESC**. Unit will remain programmed as it was originally.

5. Press **UP** and display will indicate:

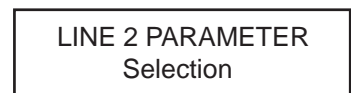

6. Press **ENT** and display will indicate current parameter selected to display on Line 2 (see Parameter List in Section 5.18 for available selections).

5.17 – STANDARD DISPLAY CONFIGURATION (con't)

- 7. Use **UP** or **DN** to scroll to desired parameter. Press **ENT** and parameter will be stored in memory and display will indicate as in Step 5.

Note: If user desires not to change the setting and return to Setup menu, press **ESC**. Unit will remain programmed as it was originally.

- 8. If DIFF. PRESSURE was selected in Step 7 above, continue with Step 9.

If CUSTOM TEXT was selected in Step 7 above, continue with Step 16.

For all other parameters, proceed to Step 11.

- 9. Press **UP** and display will indicate:

LINE 2 D.P. UNITS
Selection

- 10. Press **ENT** and display will indicate current differential pressure units. Use **UP** or **DN** to change units and press **ENT** when desired units are displayed.

- 11. Press **UP** and display will indicate:

LINE 2 FILTER
Selection

Note: Filter selection will not be available if selected parameter is ALARM SETPOINT.

- 12. Press **ENT** and display will indicate current Filter setting selected for Line 2 [0 (None), 1 (Minimum), 2, 3, or 4 (Maximum)].

- 13. Use **UP** or **DN** to scroll to desired filter setting. Press **ENT** and filter setting will be stored in memory and display will indicate as in Step 11.

- 14. Press **UP** and display will indicate:

Return to
MAIN MENU

- 15. Press **ENT** to return to Main Menu.

- 16. If Custom Text was selected in Step 7, press **UP** and display will indicate:

LINE 2 CUSTOM TEXT
Selection

- 17. Press **ENT** , display will indicate:

—

Cursor indicates position to be set.
There are 20 positions available to hold custom text.

- 18. Use **UP** or **DN** to scroll through available characters (see ASCII Chart in Section 5.18 for available characters).

5.17 – STANDARD DISPLAY CONFIGURATION (con't)

19. When desired character is displayed, press **ENT**, character will be stored and cursor will advance one position to the right.
20. Repeat Steps 18 and 19 for all 20 positions. When position 20 is entered, user will be exited back to display as in Step 16.

21. Press **UP** and display will indicate:

Return to MAIN MENU

22. Press **ENT** to return to Main Menu.

Note: In "Set Custom Text" mode, the pushbuttons can be used in the following combinations to facilitate programming:

ESC + UP: Moves position cursor to the right, one position at a time.

ESC + DN: Moves position cursor to the left, one position at a time.

ESC + ENT: Exits "Set Custom Text". Does not enter any changes to the display since the last time **ENT** was pressed.

UP + DN: Jumps up five characters at a time, to the desired character.

DN + UP: Jumps down five characters at a time, to the desired character.

Hold first key, then press second key.

5.18 – ENHANCED DISPLAY CONFIGURATION

User can select display parameter, for lines 2, 3, 4, and 5. Also, each line can have a level of filtering, 0 through 4 (4 is maximum) selected by User.

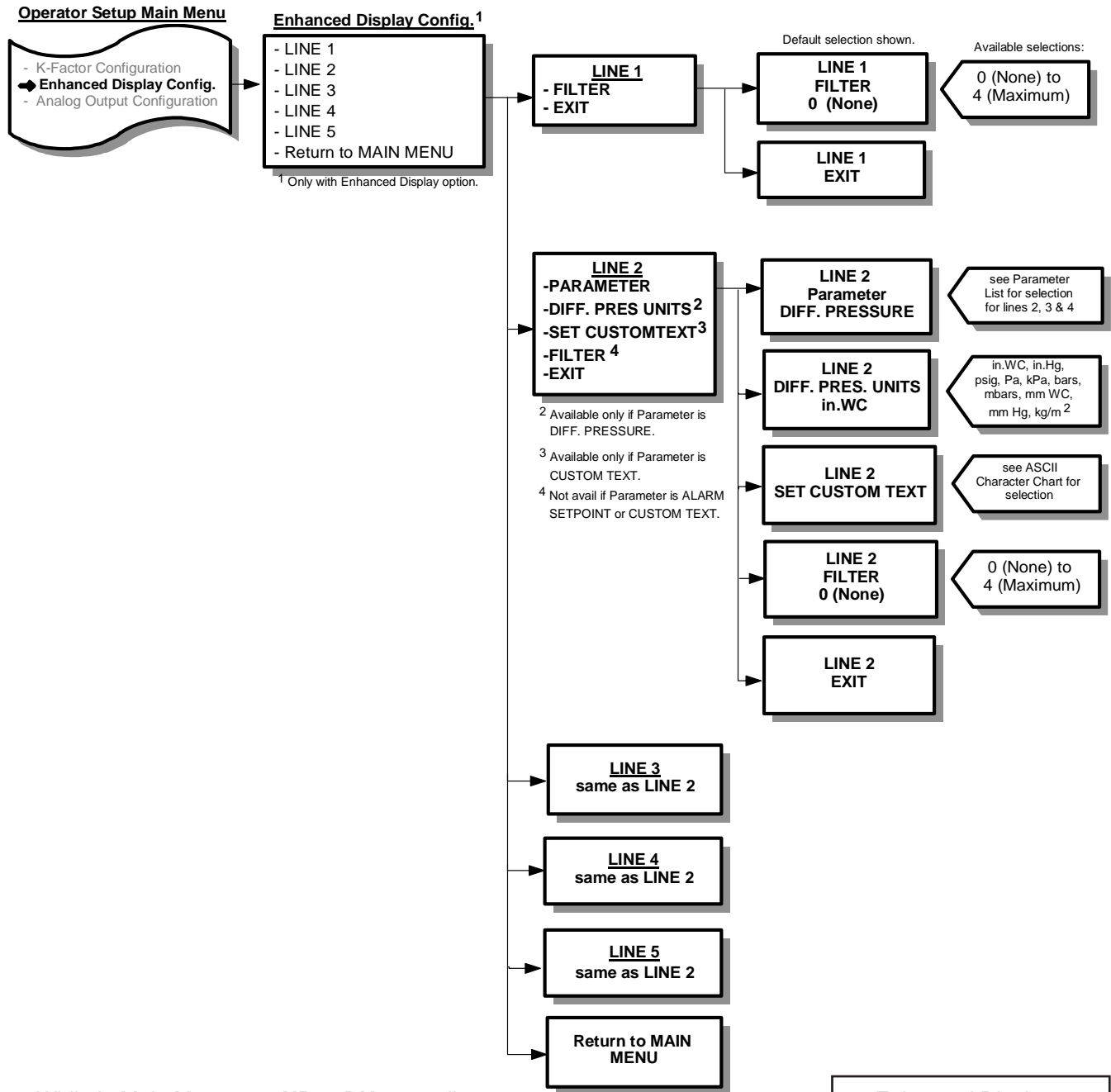

1. While in Main Menu, use **UP** or **DN** to scroll to:
2. Press **ENT** to enter Enhanced Display Configuration menu. Display will indicate:
3. Press **ENT** to enter Setup menu. Display will indicate:

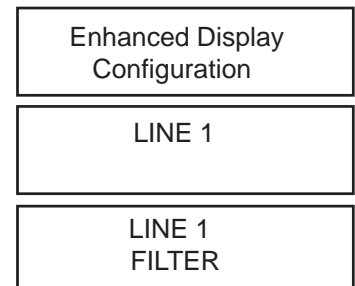

5.18 – ENHANCED DISPLAY CONFIGURATION (con't)

4. Press **ENT**, and display will indicate current setting of the filter [0 (None), 1 (Minimum), 2, 3, or 4 (Maximum)].
5. Use **UP** or **DN** to change setting. Once desired setting is displayed, press **ENT**. New setting will be stored in memory and display will return to Enhanced Display Configuration menu as in Step 3.

Note: If user desires not to change the setting and return to Enhanced Display Configuration menu, press **ESC**. Unit will remain programmed as it was originally.

6. Press **UP** and display will indicate:

LINE 1 EXIT

7. Press **ENT** then **UP** and display will indicate:

LINE 2

8. Press **ENT** and display will indicate:

LINE 2 PARAMETER

9. Press **ENT** and display will indicate current parameter selected to display on Line 2 (see Parameter List at the end of this section for available selections).

10. Use **UP** or **DN** to scroll to desired parameter. Press **ENT** and parameter will be stored in memory and display will indicate as in Step 8.

Note: If user desires not to change the setting and return to Setup menu, press **ESC**. Unit will remain programmed as it was originally.

11. If CUSTOM TEXT was selected and **ENT** pressed in Step 10, proceed to Step 20. For other parameters, continue with Step 12.

12. Press **UP** and display will indicate:

LINE 2 FILTER

Note: Filter selection will not be available if selected parameter is ALARM SETPOINT or CONTROLLER SETPOINT.

13. Press **ENT** and display will indicate current Filter setting selected for Line 2 [0 (None), 1 (Minimum), 2, 3, or 4 (Maximum)].

14. Use **UP** or **DN** to scroll to desired filter setting. Press **ENT** and filter setting will be stored in memory and display will indicate as in Step 12.

15. Press **UP** and display will indicate:

LINE 2 EXIT

16. Press **ENT** then **UP** and display will indicate:

LINE 3

5.18 – ENHANCED DISPLAY CONFIGURATION (con't)

17. Repeat Steps 8 through 16 for Lines 3, 4, and 5. The only differences being the change of Line # in the display.

18. After Line 4 has been set, Step 16 will yield a display:

Return to
MAIN MENU

19. Press **ENT** to return to Main Menu.

20. If Custom Text was selected and **ENT** pressed in Step 10, (for any line 2, 3, 4, 5), press **UP** and display will indicate:

LINE 2
SET CUSTOM TEXT

21. Press **ENT**, display will indicate:

LINE 2
SET CUSTOM TEXT
_

Cursor indicates position to be set.
There are 20 positions available to hold custom text.

22. Use **UP** or **DN** to scroll through available characters (see ASCII Chart at the end of this section for available characters).

23. When desired character is displayed, press **ENT**, character will be stored and cursor will advance one position to the right.

24. Repeat Steps 22 and 23 for all 20 positions. When position 20 is entered, user will be exited back to display as in Step 20.

25. Press **UP** and display will indicate:

LINE 2
EXIT

26. Press **ENT** then **UP** and display will indicate:

LINE 3

27. Repeat Steps 8 through 16 for Line 3 and Line 4. The only differences being the change of Line # in the display.

Note: In "Set Custom Text" mode, the pushbuttons can be used in the following combinations to facilitate programming:

ESC + UP: Moves position cursor to the right, one position at a time.

ESC + DN: Moves position cursor to the left, one position at a time.

ESC + ENT: Exits "Set Custom Text". Does not enter any changes to the display since the last time **ENT** was pressed.

UP + DN: Jumps up five characters at a time, to the desired character.

DN + UP: Jumps down five characters at a time, to the desired character.

5.18 – ENHANCED DISPLAY CONFIGURATION (con't)

PARAMETER LIST for Lines 2, 3, 4, and 5	
PARAMETER	DISPLAY in "NORMAL" MODE
NONE	
DIFF. PRESSURE*	D. PRESS
TRANSMITTER VELO [†]	VELO.
CONTROLLER OUTPUT	CTL OP
CONTROLLER SETPOINT	CTL SP
EXTERNAL SETPOINT INPUT	EXT SP
EXT. SPEC FUNC INPUT [■]	SF EXT
SPEC FUNCTION OUTPUT [■]	%DEV.
	SUM
	AVG.
	DELTA
	LO SEL
	HI SEL
ALARM LOW SETPOINT [◆]	LO SP
ALARM HIGH SETPOINT [◆]	HI SP
ALARM LOW1 SETPOINT [◆]	LO1 SP
ALARM LOW2 SETPOINT [◆]	LO2 SP
ALARM HIGH1 SETPOINT [◆]	HI1 SP
ALARM HIGH2 SETPOINT [◆]	HI2 SP
ALARM %DEV. SETPOINT ^{†■}	DEV SP
PERCENT OF PROCESS	(Display will indicate process type selected in Process Configuration.)
Bar Graph of Process	XX%
CUSTOM TEXT	
<p>* Available only if Square Root Function is ON.</p> <p>● Available only if Transmitter Flow is selected as Process Type.</p> <p>◆ Available only if Alarm Function option has been installed, and Percent Deviation has not been selected as a Special Function.</p> <p>† Available only if Percent Deviation has been selected as a Special Function.</p> <p>■ Available only if Special Function option has been installed.</p>	

} Depends on Special Function Selected

5.18 – ENHANCED DISPLAY CONFIGURATION (con't)

ASCII Character Chart										
!	*	3	<	E	N	W	`	i	r	{
"	+	4	=	F	O	X	a	j	s	
#	'	5	>	G	P	Y	b	k	t	}
\$	-	6	?	H	Q	Z	c	l	u	↑
%	.	7	@	I	R	[d	m	v	↓
&	/	8	A	J	S	¥	e	n	w	
'	0	9	B	K	T]	f	o	x	
(1	:	C	L	U	^	g	p	y	
)	2	;	D	M	V	-	h	q	z	

5.19 – ANALOG OUTPUT CONFIGURATION

User can select which process variables Output 3 and Output 4 represent.

Process variables available for output are:

- Transmitter Differential Pressure (only available when Square Root function is ON). Output represents transducer's Natural Span, *not* Operating Span.
- Special Function (only available if Special Function option is installed)
- Transmitter
- Controller

Operator Setup Main Menu

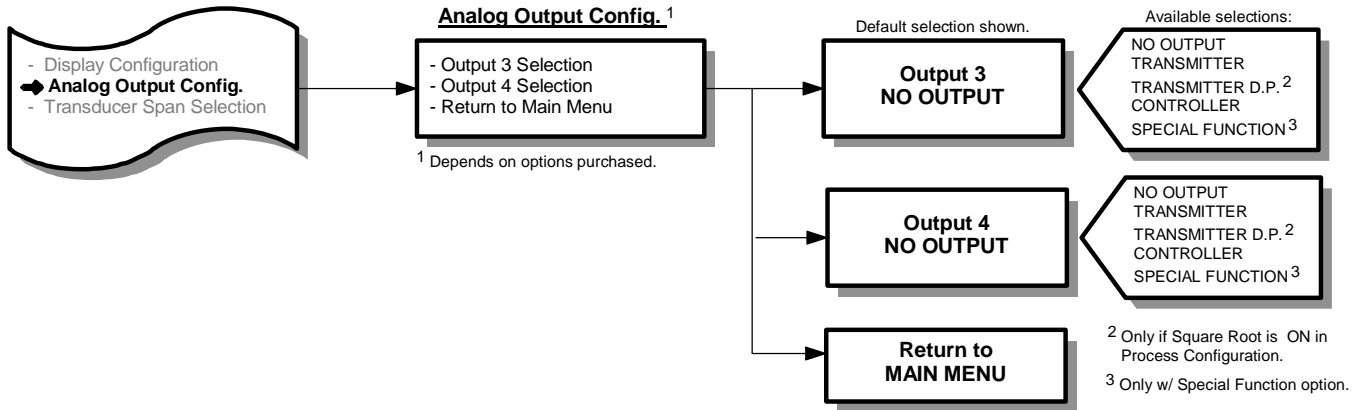

1. While in Main Menu, use **UP** or **DN** to scroll to:

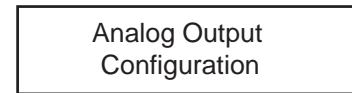

2. Press **ENT** to enter Analog Output Configuration menu. Display will indicate:

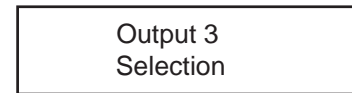

3. Press **ENT** and display will indicate current setting of Analog Output #3 (NO OUTPUT, TRANSMITTER, TRANSMITTER D.P., CONTROLLER, SPECIAL FUNCTION). Transmitter D.P. option is not available if Square Root is OFF (see Section 5.8). Special Function is not available if Special Function is OFF (see Section 5.15).

4. Use **UP** or **DN** to change setting. Once desired setting is displayed, press **ENT**. New setting will be stored in memory and display will return to Analog Output Configuration menu as in Step 2.

Note: If user desires not to change the setting and return to Analog Output Configuration menu, press **ESC**. Unit will remain programmed as it was originally.

5. Use **UP** or **DN** to select remaining parameters to be changed.

6. Follow Step 4 to make any changes to parameters.

7. To return to Main Menu, select Return to MAIN MENU in Analog Output Configuration menu and press **ENT**.

5.20 – TRANSDUCER SPAN SELECTION

Displays the transducer's natural span and operating span. The natural span represents the maximum process pressure that the transducer can accept. The displayed natural span is for user/technician reference only and should not be changed unless a new transducer of different natural span has been installed.

The operating span represents the calculated process pressure for a specific application, and can be adjusted 40% to 100% of the natural span.

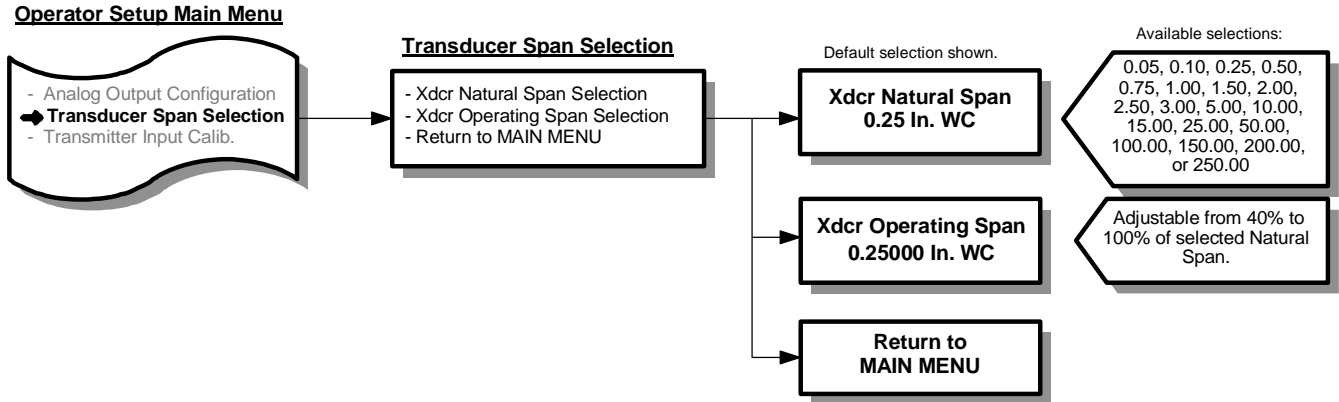

1. While in Main Menu, use **UP** or **DN** to scroll to: Transducer Span Selection
2. Press **ENT** to enter Transducer Span Selection menu. Display will indicate: Xdcr Natural Span Selection
3. Press **ENT** and display indicates the natural span of the installed transducer (0.05, 0.10, 0.25, 0.50, 0.75, 1.00, 1.50, 2.00, 2.50, 3.00, 5.00, 10.00, 15.00, 25.00, 50.00, 100.00, 150.00, 200.00, or 250.00 IN w.c.).
4. Use **UP** or **DN** to change setting. Once desired setting is displayed, press **ENT**. New setting will be stored in memory and display will return to Main Menu.

Caution: Only change setting if a transducer of different natural span has been installed.

Note: If user desires not to change the setting and return to Main Menu, press **ESC**. Unit will remain programmed as it was originally.

5. Use **UP** or **DN** to select remaining parameters to be changed.
6. Follow Step 4 to make any changes to parameters.
7. To return to Main Menu, select Return to MAIN MENU in Transducer Span Selection Menu and press **ENT**.

Note: If unit is configured as bi-polar, Xdcr Natural Span selections will be in the form of $\pm x.xx$, and Xdcr Operating Span will have a Min and Max selection.

5.21 – TRANSMITTER INPUT CALIBRATION

See Section 6.3 – Calibration for details on Transmitter Input Calibration.

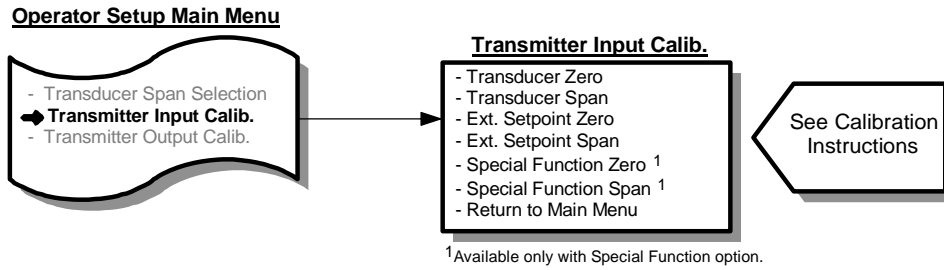

5.22 – TRANSMITTER OUTPUT CALIBRATION

See Section 6.4 – Calibration for details on Transmitter Output Calibration.

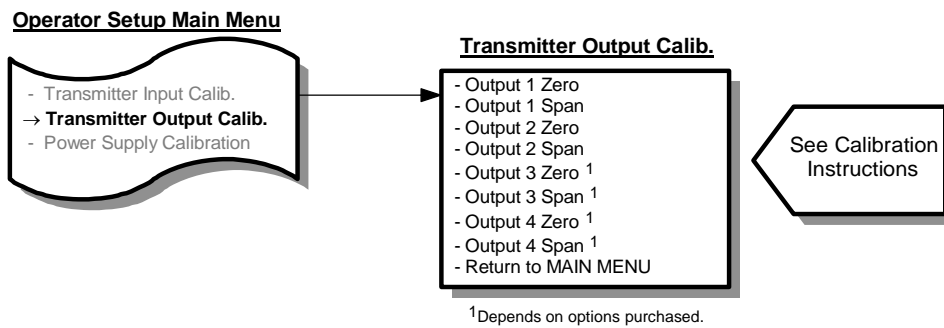

5.23 – POWER SUPPLY CALIBRATION

User can adjust power supply voltage to an optimum value. The voltage has been adjusted at the Factory and should not require adjustment.

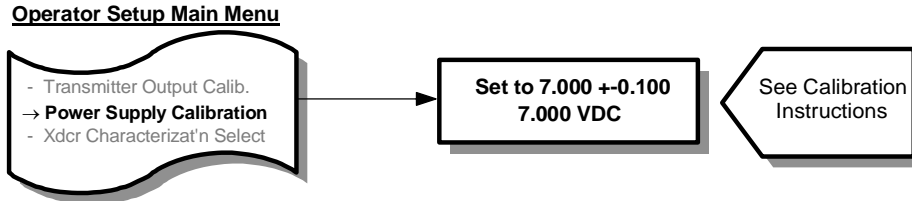

1. While in Main Menu, use **UP** or **DN** to scroll to:

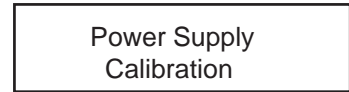

2. Press **ENT** and display will indicate current power supply voltage on line 2.

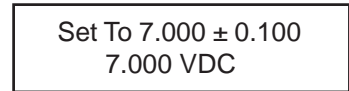

3. If supply voltage is less than 6.900V or greater than 7.100V, adjust R36 on I/O Board (see Figure 5.2) until acceptable voltage reading is displayed on line 2.

4. When done, press **ENT** to return to Main Menu.

5.24 – TRANSDUCER CHARACTERIZATION SELECTION

Allows user to enter unique transducer characterization data when the transducer has been changed.

- CAUTION:**
- User should not make any changes to the data entered in the following menu items.
 - This data has been entered by the Factory for the specific transducer installed in the unit.
 - Only if the transducer is replaced by the user should new data be entered.
 - This new data along with instructions will be provided with the new transducer from the Factory

Operator Setup Main Menu



Xdcr Character. Selection

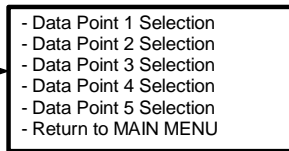

Default selection shown.

Available selections:

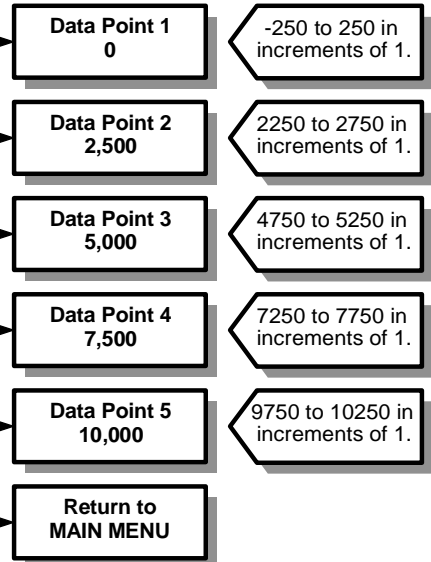

5.25 – NETWORK CONFIGURATION

Operator can turn network communications ON or OFF, select source, and assign IP addresses.

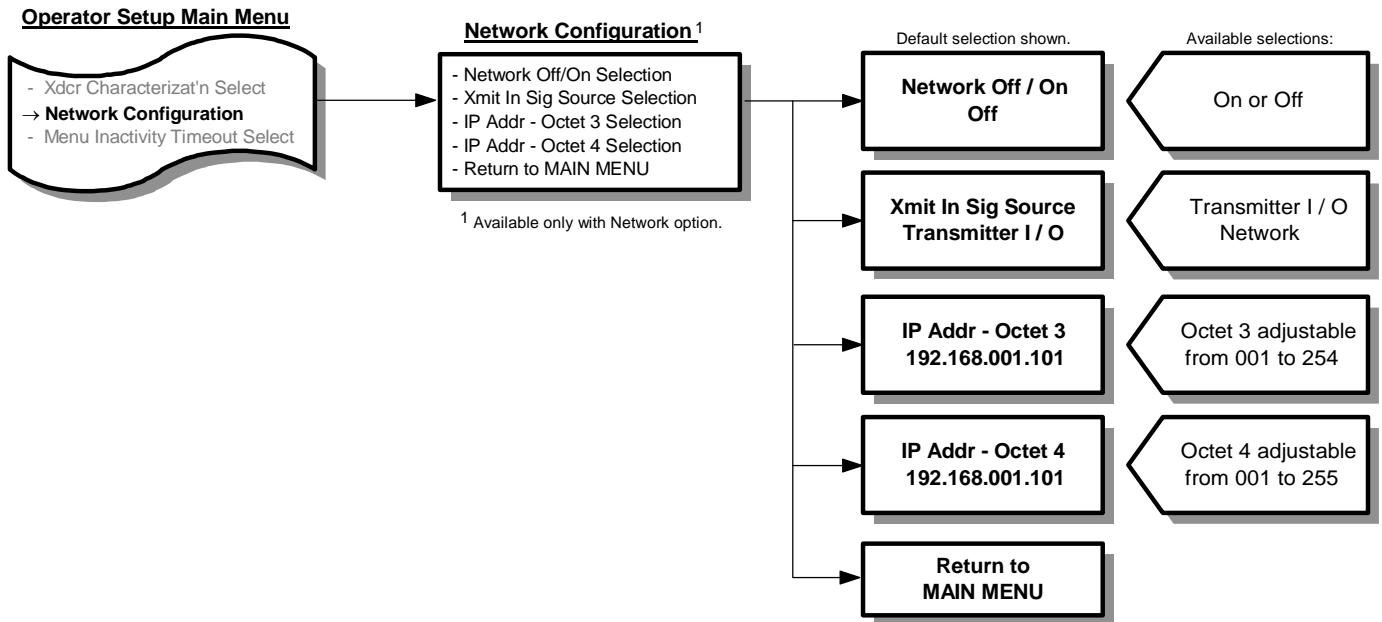

1. While in Main Menu, use **UP** or **DN** to scroll to:

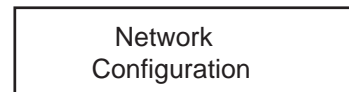

2. Press **ENT** to enter Network Configuration menu. Display will indicate:

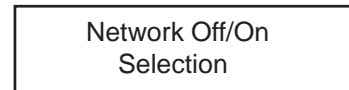

3. Press **ENT** and display will indicate current setting of Network (OFF or ON).

4. Use **UP** or **DN** to change setting. Once desired setting is displayed, press **ENT** and new setting will be stored in memory and display will return to Network Configuration menu as in Step 2.

Note: If user desires not to change the setting and return to Network Configuration menu, press **ESC**. Unit will remain programmed as it was originally.

5. Use **UP** or **DN** to select remaining parameters to be changed.

6. Follow Step 4 to make any changes to parameters.

7. To return to Main Menu, select Return to MAIN MENU in Network Configuration menu and press **ENT**.

5.26 – MENU INACTIVITY TIMEOUT SELECTION

Allows user to select a time (minutes) after which the unit returns to Normal operation if no activity in the Operator Menu.

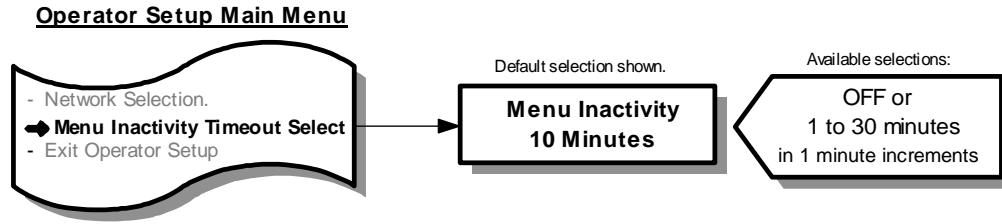

1. While in Main Menu, use **UP** or **DN** to scroll to:

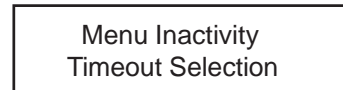

2. Press **ENT** and display will indicate current timeout value (1 to 30 minutes or OFF).
3. Use **UP** or **DN** to change timeout value. Once desired value is displayed, press **ENT**. New setting will be stored in memory and display will return to Main Menu.

Note: If user desires not to change the setting and return to Main Menu, press **ESC**. Unit will remain programmed as it was originally.

6 – CALIBRATION

This section will detail steps necessary to calibrate the VEL-trol II. Calibration is accomplished using the four programming pushbuttons detailed in Section 5.

This section can be accomplished with VEL-trol II mounted in its operating location or at a test bench in a calibration lab.

If calibrated at a test bench, VEL-trol II should be positioned in the same attitude as in its operating location.

6.1 – REQUIRED EQUIPMENT

1. Digital Manometer capable of reading to the nearest 0.001" w.c.
2. Digital Multimeter.
3. Source of clean, dry instrument air.
4. Adjustable low pressure regulator, such as AMC "Low Pressure Air Source" or equal.

6.2 – PREPARATION

1. Turn Power switch OFF on front of VEL-trol II (see Figure 4.1).
2. Remove Low and High pressure signal lines to the VEL-trol II.
3. Remove all wires connected to terminals 1 through 6 (see Figure 4.3).
4. Prepare test equipment as shown in Figure 6.1.
5. Turn Power switch ON.

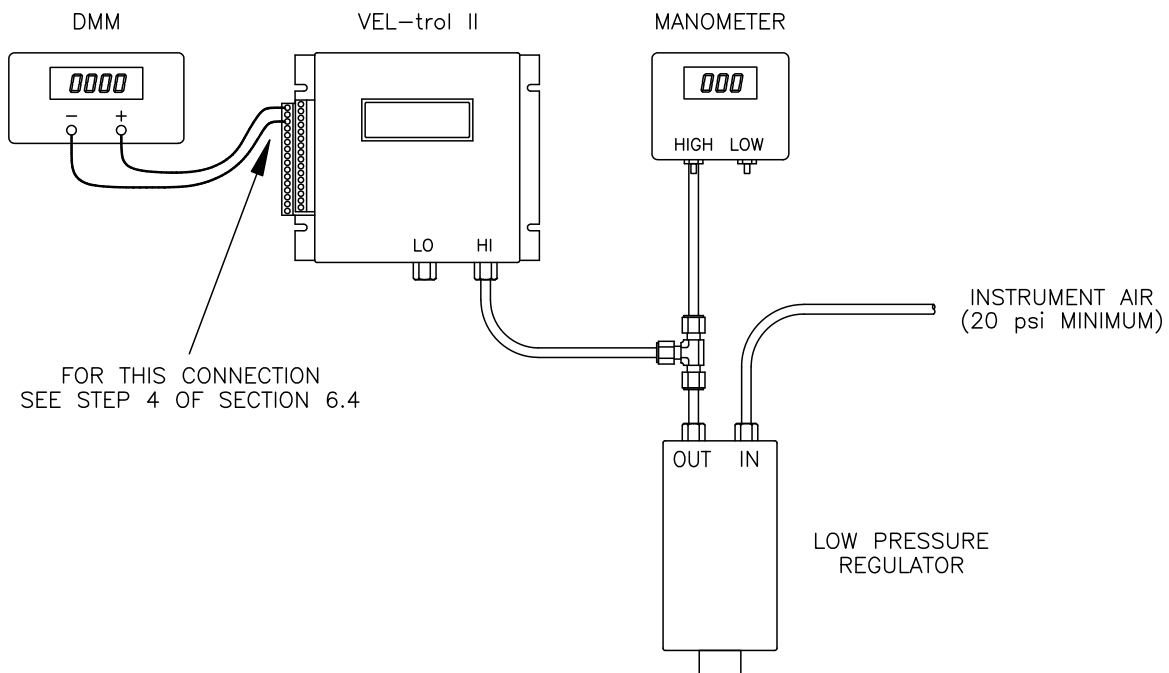

Figure 6.1

6.3 – TRANSMITTER INPUT CALIBRATION

6.3.1 For Units With Positive Differential Pressure Spans.

Zero pressure and transducer natural span pressure will be applied to the VEL-trol II, unit will be programmed to recognize these pressures as zero and span for transmitter input calibration.

1. While in Main Menu, scroll to:

Transmitter Input
Calibration

2. Press **ENT**, and display will indicate:

Transducer Zero
Calib: 0.00 in.WC

3. Press **ENT**, and display will indicate:

Transducer Zero
-- Push ENTER --

4. Press **ENT**, and display will indicate:

Transducer Zero
Settle Time:4

Display will count down to 0, after which it will indicate:

Input Zero Done
-- Push ESCAPE --

5. Press **ESC** and then **UP**, display will indicate:

Transducer Span
Calib: X.XX in.WC

6. Apply input pressure (as read on manometer) to the High port of the VEL-trol II. Adjust pressure to equal the transducer natural span value, which is indicated on the display.

7. Press **ENT**, and display will indicate:

Transducer Span
-- Push ENTER --

8. Press **ENT**, and display will indicate:

Transducer Span
Settle Time:4

Display will count down to 0, after which it will indicate:

Input Span Done
-- Push ESCAPE --

Note: If pressure input is less than 40% or greater than 110% of transmitter's maximum span range (see Factory Set-Up Information Sheet), display will indicate:

Bad Input Span
-- Push ESCAPE --

If this occurs, check input pressure (as read on manometer), and readjust as necessary. Press **ESC** and repeat Steps 6 through 8.

6.3 – TRANSMITTER INPUT CALIBRATION (con't)

6.3.1 (con't)

9. Remove input pressure from High port on VEL-trol II.

10. Press **ESC** and **UP**, display will indicate:

Ext. Setpoint Zero
Calib: Aux.1 Minimum

11. Connect a voltage/current generator adjusted for minimum value of External Setpoint input (see Factory Set-Up Information Sheet) across terminals 8 and 10 (see Figure 4.3).

12. Press **ENT**, and display will indicate:

Ext. Setpoint Zero
-- Push ENTER --

13. Press **ENT**, and display will indicate:

Ext. Setpoint Zero
Settle Time:4 Sec

Display will count down to 0, after which it will indicate:

Input Zero Done
-- Push ESCAPE --

14. Press **ESC** and **UP**, display will indicate:

Ext. Setpoint Span
Calib: Aux.1 Maximum

15. Press **ENT**, and display will indicate:

Ext. Setpoint Span
-- Push ENTER --

16. With voltage/current generator still connected as in Step 11, adjust to maximum value of External Setpoint input (see Factory Set-Up Information Sheet).

17. Press **ENT**, and display will indicate:

Ext. Setpoint Span
Settle Time:4 Sec

Display will count down to 0, after which it will indicate:

Input Span Done
-- Push ESCAPE --

Note: If span input is less than 80% or greater than 120% of External Setpoint's maximum input (see Factory Set-Up Information Sheet), display will indicate:

Bad Input Span
-- Push ESCAPE --

If this occurs, check input signal and readjust as necessary. Press **ESC** and repeat Steps 15 through 17.

18. Press **ESC** and then **UP**, and depending on whether Special Function option is installed display will indicate either:

Special Func. Zero
Calib: Aux.2 Minimum

or

Return to
MAIN MENU

19. If Special Function is installed, proceed with Step 20. If not, proceed with Step 28.

6.3 – TRANSMITTER INPUT CALIBRATION (con't)

6.3.1 (con't)

20. Connect a voltage/current generator adjusted for minimum value of Special Function input (see Factory Set-Up Information Sheet) across terminals 9 and 10 (see Figure 4.3).

21. Press **ENT**, and display will indicate:

Special Func. Zero
-- Push ENTER --

22. Press **ENT**, and display will indicate:

Special Func. Zero
Settle Time:4

Display will count down to 0, after which it will indicate:

Input Zero Done
-- Push ESCAPE --

23. Press **ESC** and **UP**, display will indicate:

Special Func. Span
Calib: Aux.2 Maximum

24. Press **ENT**, and display will indicate:

Special Func. Span
-- Push ENTER --

25. With voltage/current generator still connected as in Step 20, adjust to maximum value of Special Function input (see Factory Set-Up Information Sheet).

26. Press **ENT**, and display will indicate:

Special Func. Span
SETTLE TIME:4

Display will count down to 0, after which it will indicate:

Input Span Done
-- Push ESCAPE --

Note: If span input is less than 80% or greater than 120% of Special Function's maximum input (see Factory Set-Up Information Sheet), display will indicate:

Bad Input Span
-- Push ESCAPE --

If this occurs, check input signal and readjust as necessary. Press **ESC** and repeat Steps 24 through 26.

27. Press **ESC** and then **UP**, display will indicate:

Return to
MAIN MENU

28. Press **ENT**, and display will be in Main Menu.

6.3 – TRANSMITTER INPUT CALIBRATION (con't)

6.3.2 For Units With Negative Differential Pressure Spans.

Zero pressure and transducer natural span pressure will be applied to the VEL-trol II, unit will be programmed to recognize these pressures as zero and span for transmitter input calibration.

1. While in Main Menu, scroll to:

Transmitter Input
Calibration

2. Press **ENT**, and display will indicate:

Transducer Zero
Calib: 0.00 in.WC

3. Press **ENT**, and display will indicate:

Transducer Zero
-- Push ENTER --

4. Press **ENT**, and display will indicate:

Transducer Zero
Settle Time:4

Display will count down to 0, after which it will indicate:

Input Span Done
-- Push ESCAPE --

5. Press **ESC** and then **UP**, display will indicate:

Transducer Span
Calib: X.XX in.WC

6. Apply input pressure (as read on manometer) to the High port of the VEL-trol II. Adjust pressure to equal the transducer natural span value, which is indicated on the display.

7. Press **ENT**, and display will indicate:

Transducer Span
-- Push ENTER --

8. Press **ENT**, and display will indicate:

Transducer Span
Settle Time:4

Display will count down to 0, after which it will indicate:

Input Span Done
-- Push ESCAPE --

Note: If pressure input is less than 40% or greater than 110% of transmitter's maximum span range (see Factory Set-Up Information Sheet), display will indicate:

Bad Input Span
-- Push ESCAPE --

If this occurs, check input pressure (as read on manometer), and readjust as necessary. Press **ESC** and repeat Steps 6 through 8.

6.3 – TRANSMITTER INPUT CALIBRATION (con't)

6.3.2 (con't)

9. Remove input pressure from High port on VEL-trol II.

10. Press **ESC** and then **UP**, display will indicate:

Ext. Setpoint Zero
Calib: Aux.1 Minimum

11. Connect a voltage/current generator adjusted for minimum value of External Setpoint input (see Factory Set-Up Information Sheet) across terminals 8 and 10 (see Figure 4.3).

12. Press **ENT**, and display will indicate:

Ext. Setpoint Zero
-- Push ENTER --

13. Press **ENT**, and display will indicate:

Ext. Setpoint Zero
Settle Time:4 Sec

Display will count down to 0, after which it will indicate:

Input Zero Done
-- Push ESCAPE --

14. Press **ESC** and **UP**, display will indicate:

Ext. Setpoint Span
Calib: Aux.1 Maximum

15. Press **ENT**, and display will indicate:

Ext. Setpoint Span
-- Push ENTER --

16. With voltage/current generator still connected as in Step 11, adjust to maximum value of External Setpoint input (see Factory Set-Up Information Sheet).

17. Press **ENT**, and display will indicate:

Ext. Setpoint Span
Settle Time:4 Sec

Display will count down to 0, after which it will indicate:

Input Span Done
-- Push ESCAPE --

Note: If span input is less than 80% or greater than 120% of External Setpoint's maximum input (see Factory Set-Up Information Sheet), display will indicate:

Bad Input Span
-- Push ESCAPE --

If this occurs, check input signal and readjust as necessary. Press **ESC** and repeat Steps 15 through 17.

18. Press **ESC** and then **UP**, and depending on whether Special Function option is installed display will indicate either:

Special Func. Zero
Calib: Aux.2 Minimum

or

Return to
MAIN MENU

19. If Special Function is installed, proceed with Step 20. If not, proceed with Step 28.

6.3 – TRANSMITTER INPUT CALIBRATION (con't)

6.3.2 (con't)

20. Connect a voltage/current generator adjusted for minimum value of Special Function input (see Factory Set-Up Information Sheet) across terminals 9 and 10 (see Figure 4.3).

21. Press **ENT**, and display will indicate:

Special Func. Zero
-- Push ENTER --

22. Press **ENT**, and display will indicate:

Special Func. Zero
Settle Time:4

Display will count down to 0, after which it will indicate:

Input Zero Done
-- Push ESCAPE --

23. Press **ESC** and **UP**, display will indicate:

Special Func. Span
Calib: Aux.2 Maximum

24. Press **ENT**, and display will indicate:

Special Func. Span
-- Push ENTER --

25. With voltage/current generator still connected as in Step 20, adjust to maximum value of Special Function input (see Factory Set-Up Information Sheet).

26. Press **ENT**, and display will indicate:

Special Func. Span
Settle Time:4

Display will count down to 0, after which it will indicate:

Input Span Done
-- Push ESCAPE --

Note: If span input is less than 80% or greater than 120% of Special Function's maximum input (see Factory Set-Up Information Sheet), display will indicate:

Bad Input Span
-- Push ESCAPE --

If this occurs, check input signal and readjust as necessary. Press **ESC** and repeat Steps 24 through 26.

27. Press **ESC** and then **UP**, display will indicate:

Return to
MAIN MENU

28. Press **ENT**, and display will be in Main Menu.

6.3 – TRANSMITTER INPUT CALIBRATION (con't)

6.3.3 For Units With Bi-Polar Spans.

Minimum and maximum transducer natural span pressure will be applied to the VEL-trol II, unit will be programmed to recognize these pressures as zero and span for transmitter input calibration.

1. Connect input pressure to Low port of VEL-trol II.

2. While in Main Menu, scroll to:

Transmitter Input
Calibration

3. Press **ENT**, and display will indicate:

Transducer Zero
Calib: X.XX in.WC

4. Apply input pressure (as read on manometer) to the Low Port of the VEL-trol II. Adjust pressure to equal the positive equivalent of the minimum (negative) transducer natural span value, which is indicated on the display.

5. Press **ENT**, and display will indicate:

Transducer Zero
-- Push ENTER --

6. Press **ENT**, and display will indicate:

Transducer Zero
Settle Time:4 Sec

Display will count down to 0, after which it will indicate:

Input Zero Done
-- Push ESCAPE --

8. Press **ESC** and then **UP**, display will indicate:

Transducer Span
Calib: X.XX in.WC

9. Apply input pressure (as read on manometer) to the High Port of the VEL-trol II. Adjust pressure to equal the maximum (positive) transducer natural span value, which is indicated on the display.

10. Connect input pressure to the High port of the VEL-trol II.

11. Press **ENT**, and display will indicate:

Transducer Span
-- PUSH ENTER --

12. Press **ENT**, and display will indicate:

Transducer Span
Settle Time:4 Sec

Display will count down to 0, after which it will indicate:

Input Span Done
-- Push ESCAPE --

Note: If pressure input is less than 40% or greater than 110% of transmitter's maximum span range (see Factory Set-Up Information Sheet), display will indicate:

Bad Input Span
-- Push ESCAPE --

If this occurs, check input pressure (as read on manometer), and readjust as necessary. Press **ESC** and repeat Steps 8 through 11.

6.3 – TRANSMITTER INPUT CALIBRATION (con't)

6.3.3 (con't)

12. Remove input pressure from High port on VEL-trol II.

13. Press **ESC** and then **UP**, display will indicate:

Ext. Setpoint Zero
Calib: Aux.1 Minimum

14. Connect a voltage/current generator adjusted for minimum value of External Setpoint input (see Factory Set-Up Information Sheet) across terminals 8 and 10 (see Figure 4.3).

15. Press **ENT**, and display will indicate:

Ext. Setpoint Zero
-- Push Enter --

16. Press **ENT**, and display will indicate:

Ext. Setpoint Zero
Settle Time:4 Sec

Display will count down to 0, after which it will indicate:

Input Zero Done
-- Push ESCAPE --

17. Press **ESC** and **UP**, display will indicate:

Ext. Setpoint Span
Calib: Aux.1 Minimum

18. Press **ENT**, and display will indicate:

Ext. Setpoint Span
-- Push ENTER --

19. With voltage/current generator still connected as in Step 14, adjust to maximum value of External Setpoint input (see Factory Set-Up Information Sheet).

20. Press **ENT**, and display will indicate:

Ext. Setpoint Span
Settle Time:4 Sec

Display will count down to 0, after which it will indicate:

Input Span Done
-- Push ESCAPE --

Note: If span input is less than 80% or greater than 120% of External Setpoint's maximum input (see Factory Set-Up Information Sheet), display will indicate:

Bad Input Span
-- Push ESCAPE --

If this occurs, check input signal and readjust as necessary. Press **ESC** and repeat Steps 18 through 20.

21. Press **ESC** and then **UP**, and depending on whether Special Function option is installed display will indicate either:

Special Func. Zero
Calib: Aux.1 Minimum

or

Return to
MAIN MENU

22. If Special Function is installed, proceed with Step 23. If not, proceed with Step 31.

6.3 – TRANSMITTER INPUT CALIBRATION (con't)

6.3.3 (con't)

23. Connect a voltage/current generator adjusted for minimum value of Special Function input (see Factory Set-Up Information Sheet) across terminals 9 and 10 (see Figure 4.3).

24. Press **ENT**, and display will indicate:

Special Func. Zero
-- Push Enter --

25. Press **ENT**, and display will indicate:

Special Func. Zero
Settle Time:4 Sec

Display will count down to 0, after which it will indicate:

Input Zero Done
-- Push ESCAPE --

26. Press **ESC** and **UP**, display will indicate:

Special Func. Span
Calib: Aux.2 Maximum

27. Press **ENT**, and display will indicate:

Special Func. Span
-- Push ENTER --

28. With voltage/current generator still connected as in Step 23, adjust to maximum value of Special Function input (see Factory Set-Up Information Sheet).

29. Press **ENT**, and display will indicate:

Special Func. Span
Settle Time:4 Sec

Display will count down to 0, after which it will indicate:

Input Span Done
-- Push ESCAPE --

Note: If span input is less than 80% or greater than 120% of Special Function's maximum input (see Factory Set-Up Information Sheet), display will indicate:

Bad Input Span
-- Push ESCAPE --

If this occurs, check input signal and readjust as necessary. Press **ESC** and repeat Steps 27 through 29.

30. Press **ESC** and then **UP**, display will indicate:

Return to
MAIN MENU

31. Press **ENT**, and display will be in Main Menu.

6.4 – TRANSMITTER OUTPUT CALIBRATION

1. Scroll Main Menu to:

Transmitter Output
Calibration

2. Press **ENT**, and display will indicate:

Output 1 Zero

3. Press **ENT**, and display will indicate:

Output 1 Zero
Perform Calibration

4. Connect a DMM set for type and scale of Transmitter Output 1 (see Factory Set-Up Information Sheet) across terminals 1 and 3 on VEL-trol II (see Figure 4.3).

Note: If the output is 4-20mA, a load resistance should be in series with the DMM. This can be accomplished by connecting the actual process load or a resistor of similar value to the actual process load.

DMM should be reading minimum value; 0.00 ± 0.01 volts or 4.00 ± 0.01 mA.

5. If DMM is reading out of tolerance, use **UP** or **DN** to adjust VEL-trol II output for an acceptable DMM reading.

Depending on DMM's selected range, the **UP** or **DN** button may need to be pressed and held for a period of time before any change occurs in the DMM's display. To speed up changes in output, pushbutton combinations can be used. The following chart lists these combinations along with the associated change in output type.

PUSHBUTTON COMBINATION	4-20mA	OUTPUT TYPE 0-5VDC	0-10VDC
UP only	+0.001mA	+0.3mV	+0.6mV
DN only	-0.001mA	-0.3mV	-0.6mV
UP* + ESC	+0.01mA	+0.003V	+0.006V
DN* + ESC	-0.01mA	-0.003V	-0.006V
UP* + DN	+0.1mA	+0.03V	+0.06V
DN* + UP	-0.1mA	-0.03V	-0.06V
UP* + ESC and DN	+1.0mA	+0.3V	+0.6V
DN* + ESC and UP	-1.0mA	-0.3V	-0.6V

*Must be pressed and held before other button(s) are pressed.

6.4 – TRANSMITTER OUTPUT CALIBRATION (con't)

6. Once an acceptable zero reading is obtained, press **ENT** and then **UP** and display will indicate:

Output 1 Span

7. Press **ENT**, and display will indicate:

Output 1 Span
Perform Calibration

8. With DMM still connected as in Step 4, reading should be at maximum value; 10.00 ± 0.01 volts, 5.00 ± 0.01 volts, or 20.00 ± 0.01 mA.

9. If DMM is reading out of tolerance, use **UP** or **DN** to adjust VEL-trol II output for an acceptable DMM reading.

10. Once an acceptable span reading is obtained, press **ENT** and then **UP** and display will indicate.

Output 2 Zero

11. Repeat Steps 3 through 10 for Controller Output 2 and Analog Output 3 and 4 if available. For Controller Output 2, connect DMM across terminals 2 and 3; for Analog Output 3 across terminals 4 and 6, and for Analog Output 4 across terminals 5 and 6 (see Figure 4.3).

12. Press **UP** until display indicates:

Return to
MAIN MENU

13. Press **ENT** and scroll Main Menu to:

EXIT
User Setup

14. Press **ENT** and VEL-trol II will return to *Normal* mode of operation.

7 – MAINTENANCE

The VEL-trol II is a solid state device having few mechanical parts requiring special periodic maintenance. The following maintenance steps are not requirements, but guidelines for establishing a maintenance program for your specific installation.

Operating experience should be used to set frequency of specific types of maintenance.

7.1 – CLEANLINESS

- Periodically inspect VEL-trol II for build-up of dust and debris.
- Keep field wiring terminal strips clean to preclude shorting between terminals.
- Verify condensation (or other sources of liquids) are not present inside the VEL-trol II.

7.2 – MECHANICAL

- Verify pressure signal connections are secure.
- Inspect pressure signal lines for any cracks or leaks.
- Verify mounting hardware is secure.

7.3 – ELECTRICAL

- Periodically inspect all wiring to the VEL-trol II for good connections and absence of corrosion.

7.4 – CALIBRATION

- VEL-trol II should have calibration verified annually as a minimum.

8 – TROUBLESHOOTING

Personnel should be familiar with the operation of the VEL-trol II (see Section 5) before performing any troubleshooting.

Note: Prior to performing any troubleshooting, turn power switch OFF. After 10 seconds, turn power switch ON. If problem still exists, proceed with troubleshooting steps.

<i>Problem</i>	<i>Solution</i>
No Display and "CPU Activated" LED is not lit.	<ul style="list-style-type: none"> – Verify input 24 VAC/VDC power is connected to Terminals 15 and 16. – Verify power switch is in the ON position. – Check fuse F2 (see Section 9 for location). – Replace I/O Board.
No output or incorrect output (Transmitter Output 1) and display responding correctly with process change.	<ul style="list-style-type: none"> – Review Factory Set-Up Information Sheet for type of output. – Check terminal strip wiring for proper installation. – Verify jumpers are correct for desired type of output (see Section 4.6). – Check fuse 3 (see Section 9 for location). – Perform Transmitter Output Calibration (see Section 6). – Replace I/O Board.
No output or incorrect output (Transmitter Output 1) and display not responding or correctly with process change.	<ul style="list-style-type: none"> – Verify pressure signal lines are connected correctly. – Check for leaky or obstructed lines between VEL-trol II and process sensor. – Check for kinked internal signal pressure lines in transmitter base. – Replace Transducer. – Replace CPU Board.
No output or incorrect output. (Analog Output 3 or 4).	<ul style="list-style-type: none"> – Verify correct output is selected (see Section 5.19). – Verify correct input is applied for process application or special function (see Section 4.5) – Verify jumpers are correct for desired type of output (see Section 4.6). – Check wiring for proper installation. – Verify menu configuration setup is correct for process application or special function. – Replace I/O Board.
Special Function not working.	<ul style="list-style-type: none"> – Verify that Special Function is ON and desired type is selected (see Section 5.15). – Verify special function parameters (depends on type selected) are configured properly (see Section 5.15). – Verify any required external input is connected properly (see Section 4.5). – Verify any required external input is calibrated properly (see Section 6.3). – Replace I/O Board.
No Controller Output 2	<ul style="list-style-type: none"> – Review Factory Set-Up Information Sheet for type of output. – Check wiring for proper installation. – Verify jumpers are correct for desired type of output (see Section 4.6). – Verify Controller parameters are configured properly (see Section 5.14). – Verify that process conditions exist that require controller output. – Verify external setpoint is properly connected and jumpers are correct for type of input. Note: This is only required if desired and command signal has been sent to utilize external setpoint.
Controller Output remains constant (other than minimum or maximum) but process is not at setpoint.	<ul style="list-style-type: none"> – Verify Controller operation is automatic (see Section 5.14). – Verify Controller internal setpoint is at desired value (see Section 5.14) and external setpoint (if utilized) is at desired value.
<p>If after following the Troubleshooting steps the VEL-trol II continues to operate improperly, contact the Service Department for further assistance (see Section 10).</p>	

8 – TROUBLESHOOTING (con't)

Personnel should be familiar with the operation of the VEL-trol II (see Section 5) before performing any troubleshooting.

<i>Problem</i>	<i>Solution</i>
Controller Output is at maximum or minimum value, process is at maximum and Controller will not modulate.	– Verify Controller action selected (see Section 5.14) is correct for application.
Controller Output is at maximum or minimum, process is at minimum, and Controller will not modulate.	– Verify soft start dry contact has been received, if utilized (see Section 4.5).
Controller Output continually changes and will not stabilize.	– Verify no other control devices are interfering with process. – Adjust tuning parameters (see Section 5.14).
AUTO-zero Function is not working.	– Verify AUTO-zero is ON and interval is properly set (see Section 5.10). – Replace I/O Board.
"AUTO-zero in Progress" LED is continuously lit.	– Zero value measured during AUTO-zero cycle is between 90 and 100% of span. Transmitter Input Calibration should be performed as soon as possible (see Section 6.3). – Replace Transducer Board.
"AUTO-zero in Progress" LED is flashing rapidly.	– Zero value measured during AUTO-zero cycle is greater than 100% of span. Transmitter Input Calibration should be performed immediately (see Section 6.3). – Replace Transducer Board.
AUTO-purge Function is not working.	– Verify AUTO-purge is on, interval and activation are properly set (see Section 5.11). – Check for proper terminal strip wiring and connections (see Section 4.5).
AUTO-purge Function goes through cycle but purge panel does not initiate.	– Verify correct wiring to purge panel (see Section 4.5). – Check Fuse F1 (see Figure 5.2 for location).
Alarms not working.	– Verify that Alarm is ON and setpoints are set to correct value (see Section 5.13). – Check for proper terminal strip wiring and connections (see Section 4.5). – Replace I/O Board.
"CPU Activated" LED is not flashing	– Turn power switch OFF and back ON. – Replace CPU Board.
"Unreliable" is displayed on Line 1 of the display.	– Process signal is outside of –10% to +110% of the calibrated process range. – Independently verify flow. If measured flow is higher than VEL-trol's Process Maximum, contact Factory to discuss re-spanning.
Unable to access Operator Setup	– If the password has changed from the factory default of 1,111 and forgotten, Operator can access the Password Selection Menu by sequentially pressing UP, DN, UP, and ESC.
<p>If after following the Troubleshooting steps the VEL-trol II continues to operate improperly, contact the Service Department for further assistance (see Section 10).</p>	

9 – PARTS LIST

The following drawing with part numbers lists components of the VEL-trol II that are easily replaced by the user. When contacting the Customer Service Department about parts, please have the applicable Factory Set-Up Information sheet available for reference. To inquire about price and availability of a specific part number, please contact the Customer Service Department at:

Phone: 1-707-544-2706
1-800-AIRFLOW

FAX: 1-707-526-2825

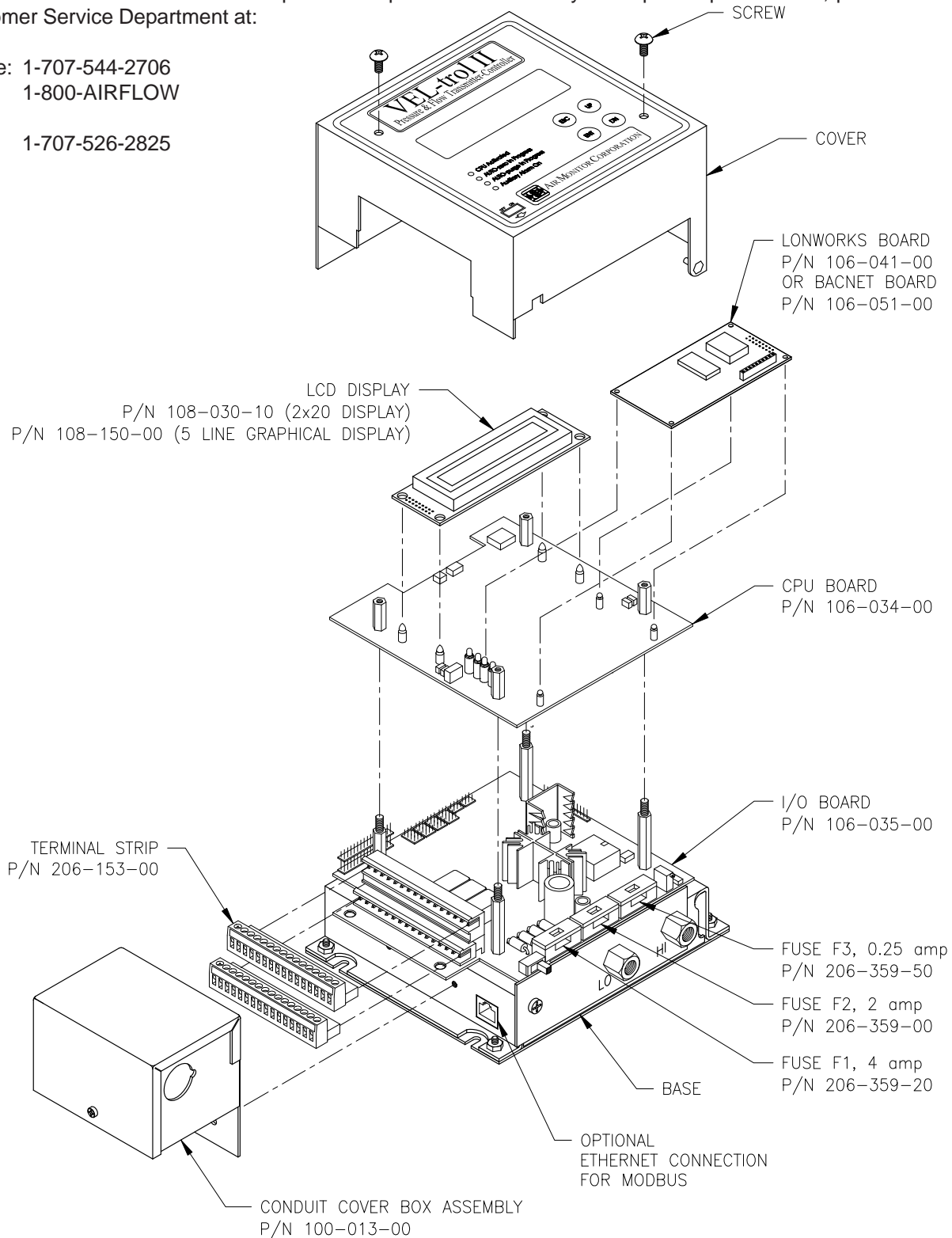

9 – PARTS LIST

The following drawing with part numbers lists components of the VEL-trol II that are easily replaced by the user. When contacting the Customer Service Department about parts, please have the applicable Factory Set-Up Information sheet available for reference. To inquire about price and availability of a specific part number, please contact the Customer Service Department at:

Phone: 1-707-544-2706
1-800-AIRFLOW

FAX: 1-707-526-2825

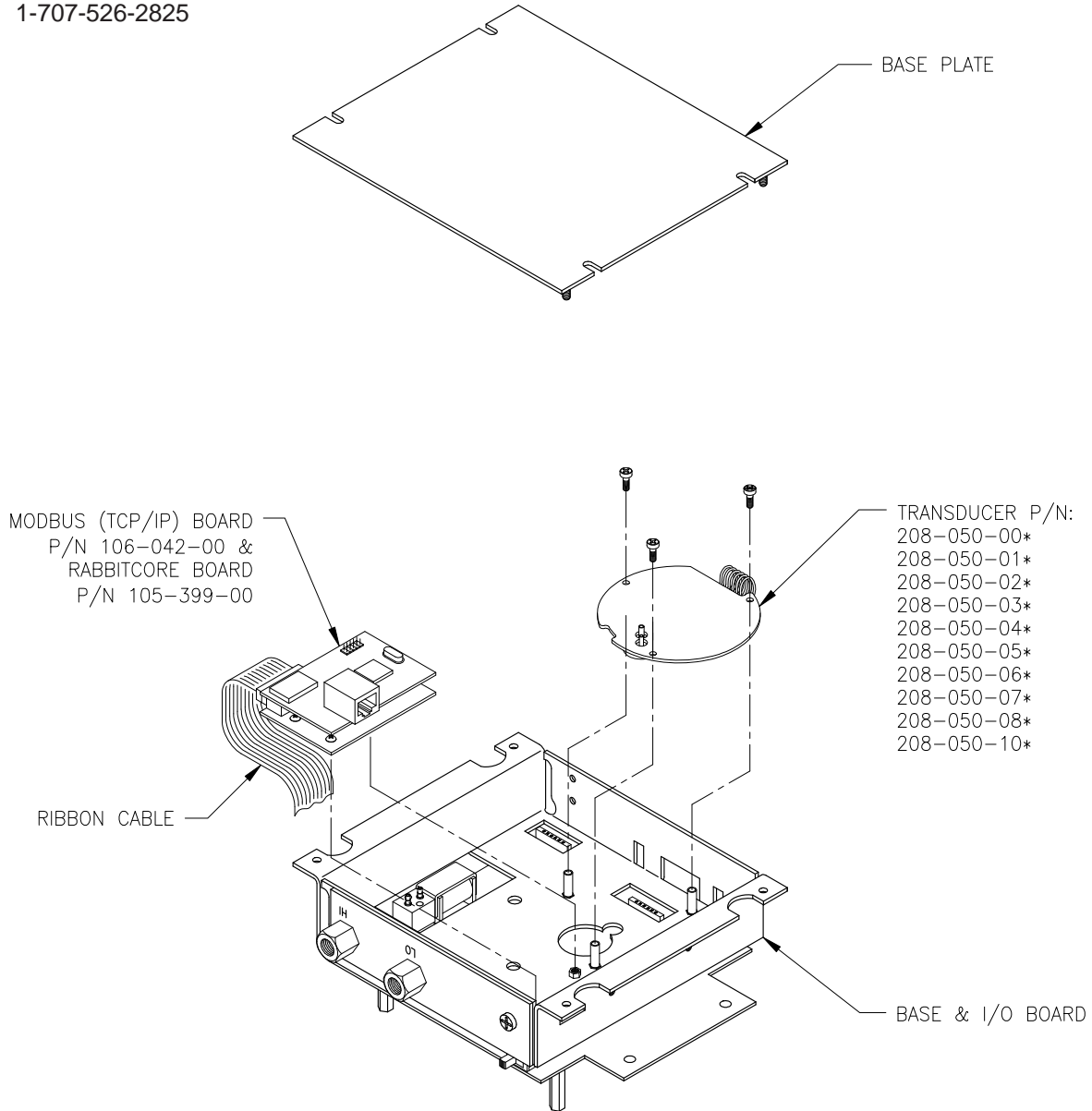

* NOTE: REFER TO FACTORY SET-UP INFORMATION SHEET TO DETERMINE WHICH TRANSDUCER IS UTILIZED IN YOUR VEL-trol II.

10 – CUSTOMER SERVICE

10.1 – CUSTOMER SERVICE/TECHNICAL SUPPORT

Air Monitor Corporation provides in-house technical support for our products:

Monday through Friday
7 am to 5 pm (pst)
Phone: 707-544-2706 or 1-800-AIRFLOW
Fax: 707-526-2825

Additionally, on-site technical assistance is available. Before contacting the Customer Service Department, please ensure any applicable troubleshooting steps outlined in Section 8 have been performed.

10.2 – REPAIRS/RETURNS

If after contacting the Customer Service Department it is determined that equipment will require return to Air Monitor Corporation for further repair, a Return Authorization number will be issued by the Customer Service Department. A Confirmation of Return Authorization with shipping instructions will be sent via facsimile or e-mail.

Equipment to be returned to Air Monitor should be returned in its original shipping container if possible. If this is not possible, ensure equipment is packaged sufficiently to protect it during shipment.

CAUTION
All damage occurring during transit is the Customer's responsibility.

List the Return Authorization (R/A) number on the packing list and clearly mark this number on the outside of each shipping container.

Costs associated with return of equipment to Air Monitor are the customer's responsibility regardless whether the repair/return is under warranty.

10.3 – WARRANTY REPAIRS/RETURNS

Once the Customer Service Department determines that the equipment repair is under warranty, the item will be repaired and returned to the customer at no charge.

10.4 – NON-WARRANTY REPAIRS/RETURNS

Customer will be invoiced for all parts and labor required for the repair of equipment. Return shipping charges will also be added to invoice.

10.5 – FIELD SERVICE

Requests for field service should be made to the Customer Service Department, who will coordinate sending a technician to customer's site.

Phone: 707-544-2706 or 1-800-AIRFLOW
Fax: 707-526-2825

Upon completion of work, technician completes a Field Service Report and gives a copy to the customer. Field service is charged on a daily basis and all travel expenses are also added to customer's invoice.

APPENDIX A

BACnet over RS485 Signal Wire Connections and Network Configuration

The VEL-trol II Transmitter with BACnet option provides a differential bus transceiver designed to be compatible with the TIA/EIA-485-A specification and the BACnet MS/TP protocol. Receiver inputs incorporate an idle bus failsafe feature which eliminates the need for system network biasing. The RS485 presents a 1/4 unit load to the network which allows up to 128 VEL-trol II Transmitters to be present on the network. On board field selectable switches allow for selecting network end of line termination. Address selection and network baud rate are selected via the Network Configuration section in the Transmitter's Operator Setup menu.

Connect the RS-485 wiring to the VEL-trol II terminals as follows:

Signal	Terminal
Network Ground	18
Net A or Net+	19
Net B or Net-	20

The VEL-trol II's BACnet objects consist of the following types:

Device Type	Device Object	Default Units
Analog Input	Air Flow	CFM
Analog Input	Differential Pressure	In. WC

Set the S1 Termination switches on the BACnet module (see Section 9) as follows:

Termination Type	S1 Switch Position		
	1	2	3
No Termination	OFF	OFF	OFF
End of Line	ON	OFF	OFF
Fail-safe Bias	ON	ON	ON

Note that the Fail-safe Bias termination includes End of Line termination.

The VEL-trol II's Network Configuration menu consists of the following items:

Network Configuration Item	Range	Default Value
Network Off/On	Off or On	On
BACnet InstanceID Selection	0 – 4,194,303	1
BACnet Address Selection	0 – 127	1
BACnet Max Masters Selection	1 – 127	127
BACnet Baud Rate Selection	9600, 19200, 38400, 76800	38400

APPENDIX A

LonWorks Signal Wire Connections and Network Configuration

The VEL-trol II Transmitter with BACnet option provides a differential bus transceiver designed to be compatible with the TIA/EIA-485-A specification and the BACnet MS/TP protocol. Receiver inputs incorporate an idle bus failsafe feature which eliminates the need for system network biasing. The RS485 presents a 1/4 unit load to the network which allows up to 128 VEL-trol II Transmitters to be present on the network. On board field selectable switches allow for selecting network end of line termination. Address selection and network baud rate are selected via the Network Configuration section in the Transmitter's Operator Setup menu.

Connect wiring to the Transmitter terminals as follows:

Signal	Terminal
Network Ground	18
Lon A	19
Lon B	20

The VEL-trol II provides two output variables:

SNVT	SNVT Index	Measurement	Units	Type Category	Type Size
SNVT_flow_f	53	Flow Volume	Liters/Sec	Floating Point	4 bytes
SNVT_temp_p	105	Temperature	°C x 100	Signed Long	2 bytes

APPENDIX A

Modbus over TCP Signal Wire Connections and Network Configuration

Modbus over TCP implementation includes the following data types:

Modbus Points and Addresses

Function	Function	Data Type	Register Address	Discrete Bit
Read Input Register	Primary Process	float	31001	
Read Input Register	Process Units	int	31003	
Read Input Register	Temperature	float	31004	
Read Input Register	Temperature Units	int	31006	
Read Input Register	Absolute Pressure	float	31007	
Read Input Register	Absolute Pressure Units	int	31009	
Read Input Register	Differential Pressure	float	31010	
Read Input Register	Differential Pressure Units	int	31012	
Read Input Register	Special Function Output	float	31013	
Read Input Register	Special Function Units	int	31015	
Read Discrete	AUTO-purge Acknowledge	int	11001	BIT0
Read Discrete	AUTO-cal Acknowledge	int	11001	BIT1
Read Discrete	AUTO-zero Acknowledge	int	11001	BIT2
Write Discrete*	Start/Stop Purge	int	11	X
Write Discrete*	Perform Calibration	int	12	X
Write Holding	Damper Position	Int	41001	

Table 1 – Modbus Register Definitions

***Note:**

- Writing the discrete register value of 11 will start a purge cycle.
- If the purge cycle is in progress, a write of the discrete register value of 11 will stop the purge cycle.
- A write of the discrete register value 12 will cause the transmitter to perform a zero calibration.

APPENDIX A

Modbus over TCP (con't)

Units are encoded as follows:

Transmitter Codes for Units of Measure

Process Type	Value	Units
Differential Pressure	0	in.WC
	1	in.Hg
	2	psig
	3	Pa
	4	kPa
	5	bars
	6	mbars
	7	mm WC
	8	mm Hg
	9	kg/m2
	10	%
Velocity	11	FPS
	12	FPM
	13	FPH
	14	m/s
	15	m/m
	16	m/hr
	17	AFPS
	18	AFPM
	19	AFPH
	20	Am/s
	21	Am/m
	22	Am/hr
	23	SFPS
	24	SFPM
	25	SFPH
	26	Sm/s
	27	Sm/m
	28	Sm/hr
	29	Nm/s
	30	Nm/m
31	Nm/hr	
	32	%
Flow	33	CFS
	34	CFM
	35	CFH
	36	l/s
	37	l/m
	38	l/hr
	39	m3/s
	40	m3/m
	41	m3/hr
	42	ACFS

Process Type	Value	Units
Flow (con't)	43	ACFM
	44	ACFH
	45	Al/s
	46	Al/m
	47	Al/hr
	48	Am3/s
	49	Am3/m
	50	Am3/h
	51	SCFS
	52	SCFM
	53	SCFH
	54	Sl/s
	55	Sl/m
	56	Sl/hr
	57	Sm3/s
	58	Sm3/m
	59	Sm3/h
	60	Nl/s
	61	Nl/m
	62	Nl/hr
	63	Nm3/s
	64	Nm3/m
	65	Nm3/h
	66	lb/s
	67	lb/m
	68	lb/hr
	69	T/hr
	70	T/day
	71	gm/s
	72	kg/s
	73	kg/m
	74	kg/hr
	75	%
Temperature	76	°F
	77	°C
	78	°R
	79	°K
Absolute Pressure	80	in.Hg
	*81	psia
	*82	kPa
	*83	mbars
	*84	mm Hg