

## LO-flo PITOT TRAVERSE STATION MODEL FR

### STANDARD CONSTRUCTION

<b>Casing &amp; Reducers:</b>	Schedule 10 Type 316 stainless steel pipe (3/4" size is Schedule 5).
<b>Flanges:</b>	150 lb., raised face, Type 316 stainless steel.
<b>Airflow Straightener:</b>	Type 316 stainless steel.
<b>Total Pressure Header:</b>	Type 316 stainless steel tubing.
<b>Static Pressure Chamber:</b>	Type 316 stainless steel.
<b>Casing Depth:</b>	See Dimensional Information below.
<b>Connection Fittings:</b>	1/4" FPT.

### PERFORMANCE SPECIFICATIONS

<b>Operating Temperature:</b>	Continuous operation to 900 °F.
<b>Resistance to Flow:</b>	0.3 times the velocity head (pressure) of the design flow rate.

### CONSTRUCTION OPTIONS

#### Flanges

- 1/4" thick 316 SS, to match 150# pattern
- 10 ga 316 SS, 1" wide, no bolt holes

#### Signal Fitting Adapters

- 1/4" Compression, stainless steel
- 1/2" Compression, stainless steel

#### Casing

- Schedule 40, Type 316 SS pipe.

#### Temperature Sensor w/Transmitter

- Single-point 100 ohm, platinum RTD.

### DIMENSIONAL INFORMATION

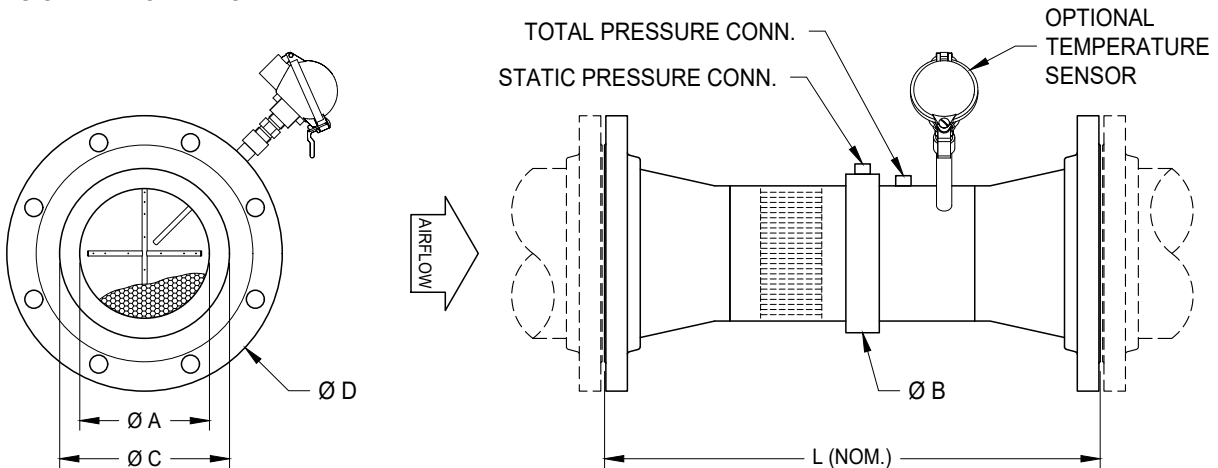

LO-flo SIZE (in)	PIPE SCHED.	Ø A" (I.D.)	Ø B" (O.D.)	REDUCER OPTION			L" NOMINAL	QTY. OF T.P. SENSORS	QTY. OF S.P. TAPS	AIRFLOW STRAIGHTENER
				SIZE	Ø C" (O.D.)	Ø D" (O.D.)				
.75	5	.92	1.66	1.00	1.315	4.25	16.12	4	4	1/8" x 2" DEEP
				1.25	1.660	4.62	16.12			
				1.50	1.900	5.00	17.12			
1	10	1.097	1.90	1.50	1.900	5.00	17.25	4	4	1/8" x 2" DEEP
				2.00	2.375	6.00	18.25			
1.25	10	1.442	2.375	2.00	2.375	6.00	18.25	6	6	1/8" x 2" DEEP
				2.50	2.975	7.00	19.25			
1.50	10	1.682	3.50	2.00	2.375	6.00	18.25	6	6	1/8" x 2" DEEP
				2.50	2.875	7.00	19.25			
				3.00	3.500	7.50	19.25			
2	10	2.157	3.50	3.00	3.500	7.50	19.25	8	6	1/8" x 2" DEEP
				3.50	4.000	8.50	20.25			
				4.00	4.500	9.00	20.25			
3	10	3.260	4.50	4.00	4.500	9.00	20.25	14	8	1/8" x 2" DEEP
				5.00	5.562	10.00	22.25			
				6.00	6.625	11.00	23.25			
4	10	4.260	5.563	6.00	6.625	11.00	23.25	14	8	1/4" x 3" DEEP
				8.00	8.625	13.50	24.25			
5	10	5.295	6.625	6.00	6.625	11.00	23.30	14	8	1/4" x 3" DEEP
				8.00	8.625	13.50	24.30			
6	10	6.357	7.625	8.00	8.625	13.50	24.30	14	8	1/4" x 3" DEEP

P.O. Box 6358, Santa Rosa, CA 95406 (707) 544-2706  
www.airmonitor.com amcsales@airmonitor.com