

VOLU-probe, VOLU-probe/SS VOLU-probe/VS, VOLU-probe/AS, VOLU-probe/1P MINIMUM INSTALLATION REQUIREMENTS

INSTALLATION CONSIDERATIONS. Installation factors to be considered when applying the VOLU-probe are as follows:

Turbulent Airflow. The unique design of the total and static pressure sensors of the VOLU-probe permits accurate flow measurement in the presence of moderate air turbulence. The distances from air turbulence producing fittings, transitions, etc., shown below are the minimum requirements for installation to assure accurate airflow measurement. Wherever possible, the VOLU-probe should be installed with longer runs of straight duct (or clearances) than shown.

Stratified Airflow. The VOLU-probe should be mounted so that the probe crosses any airflow stratification to permit sensing the varied velocity profile and obtain an average airflow measurement.

Airborne Contaminants. The levels of air filtration and cleanliness associated with commercial HVAC Systems, whether supply/return/exhaust/ outside air, are satisfactory for operation of the VOLU-probe. Applications containing airborne contaminants may require periodic manual or automatic cleaning using compressed air applied to the signal fittings, and/or physical cleaning.

Direction of Airflow. The VOLU-probe will function only with the probe mounted so the total pressure sensing holes are directed into the approaching airflow. To prevent improper installation, each VOLU-probe is marked with an arrow indicating the required direction of airflow.

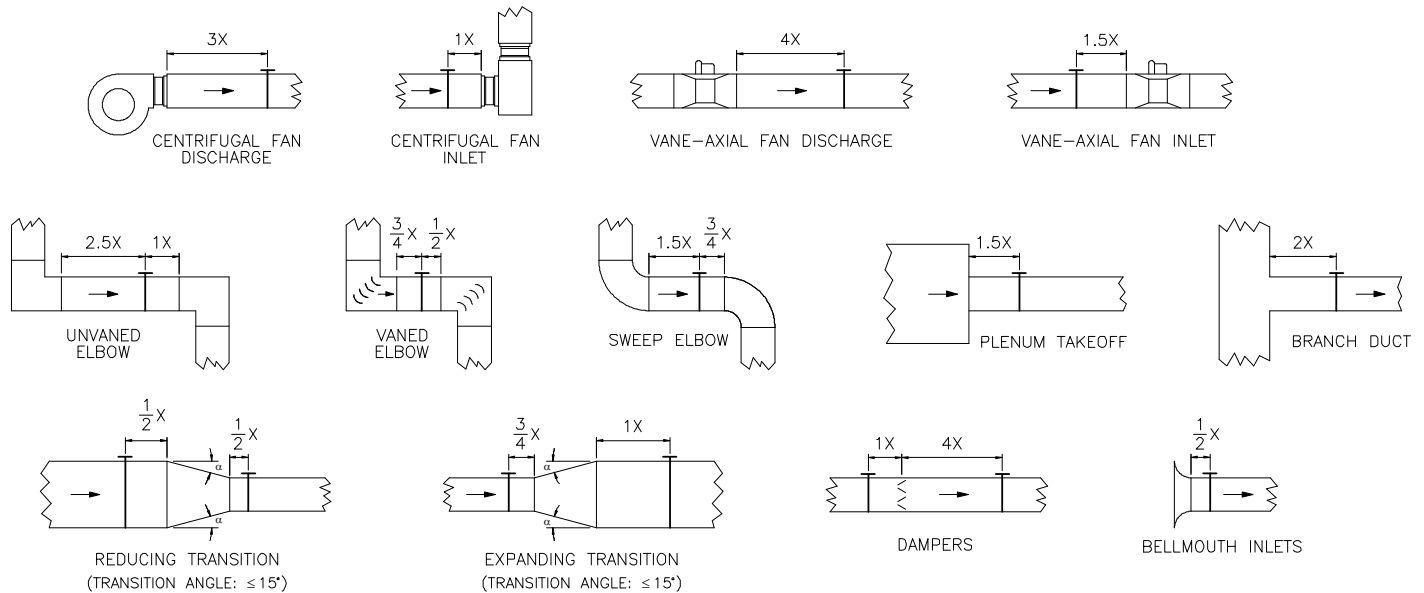

Equivalent Duct Diameter X

Rectangular Duct: $X = \frac{2(H \times W)}{H + W}$

Circular Duct: $X = \text{Duct Diameter}$

