

# LO-flo/SS

## Pitot Traverse Station



# LO-flo/SS

## Product Description

The LO-flo Pitot Traverse Station is a combination air equalizer-straightener with self-averaging Pitot tube traverse station. The LO-flo is fabricated entirely of Type 316 stainless steel with all welded construction. It is capable of operation up to 900°F and is suitable for application to corrosive gases within the limitation of the 316 stainless steel construction.

The LO-flo provides highly accurate measurement of low air volumes of 2 to 2000 CFM for monitoring, indicating, and controlling applications when coupled with ultra-low span electronic differential pressure or flow transmitters (such as the Air Monitor VELTRON II, MASS-tron II, and VELTRON DPT-*plus* trans-mitters). See respective product brochures for operating ranges and performance data.

## How It Works

**Equal Area Traverse.** Total and static pressure sensors are positioned so that each sensor represents an equal portion of the station's cross-sectional area. The total pressure sensors are the only means for sensing the multiple velocity pressures in the airstream profile, therefore, a maximum number of total pressure sensors are utilized. Since the static pressure across the station is relatively uniform, a lesser number of static pressure sensors are utilized.

**Equal Weighted Average.** The "averaging" process in the airflow measuring station manifolds is critical to maintaining high measurement accuracy. Unlike a manual Pitot tube traverse where individually taken velocity readings are totaled and mathematically averaged, the airflow measuring station must pneumatically average all of the sensed total pressure values in a manner that gives equal weight to each value. The adjacent figure illustrates how total pressure sensors are positioned to represent each cross-section equal area in a balanced pattern to achieve equal weighted averaging.

**Airflow Processing.** To assure extremely high levels of measuring accuracy (2% of actual flow or better) under adverse conditions caused by turbulent, rotating, and multi-directional airflows normally present directly downstream from duct elbows, transitions, etc., the LO-flo uses open, parallel cell, honeycomb panels to "process" the air into straightened flow just prior to the total pressure measurement plane. These honeycomb panels sharply reduce the need for long, straight runs of duct before and after the station to obtain accurate flow measurement.

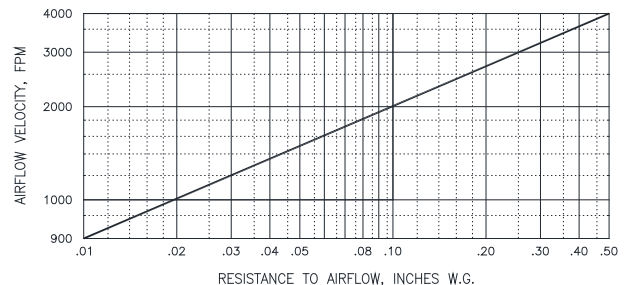
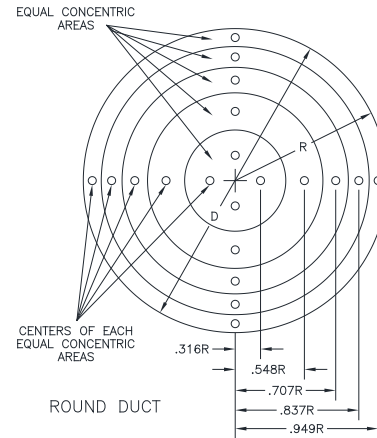

## Specifications

### Accuracy

2% of actual flow.

### Operating Temperature

Continuous operation to 900°F.

### Design Maximum Pressure

150 psig.

### Casing

Type 316 stainless steel pipe.

### Casing Depth

See rear cover for detailed dimensions.

### Flanges

150 lb. raised face, Type 316 stainless steel for Models F and FR.

### Air Equalizer – Straightener Cell

Type 316 welded stainless steel cell.

2" deep x 1/8" cell for sizes 3/4" up to 3".

3" deep x 1/4" cell for sizes 4" up to 8".

### Total Pressure Manifold

Type 316 stainless steel tubing.

### Static Pressure Chamber

Type 316 stainless steel.

### Signal Connections

1/4" FPT.

### Special Construction

10 ga and 1/4" plate flanges. Integral RTD temperature sensor and transmitter.

# Pitot Traverse Station

## Construction Features

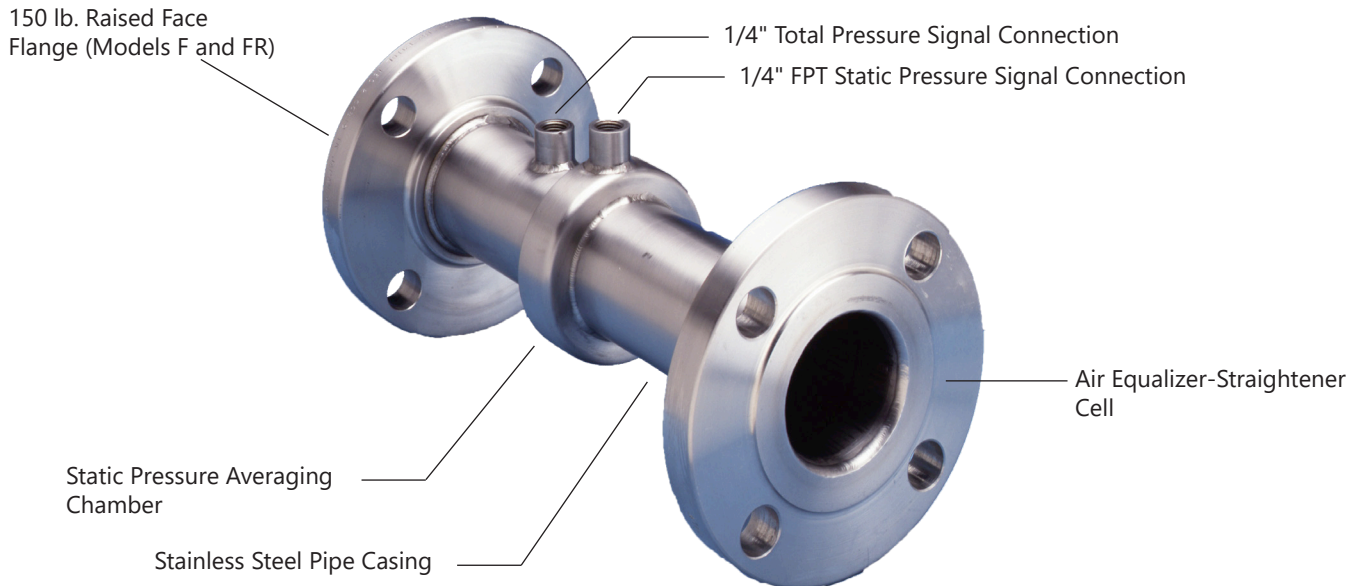

## Minimum Installation Requirements

**Note:** LO-flo locations shown are **not** ideal. The locations indicate the **minimum** clearance required from turbulence producing sources. Wherever possible, the LO-flo should be installed where straight runs exist.

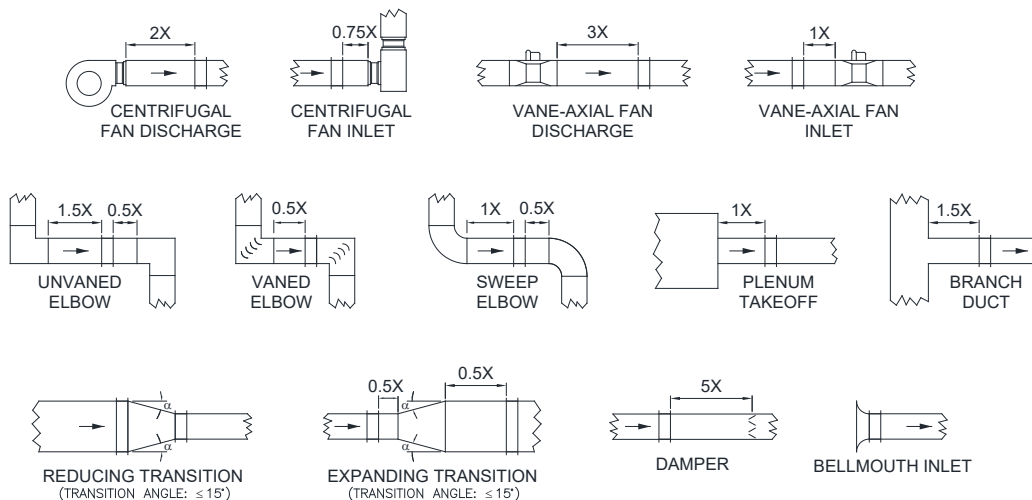

## Suggested Specification

Provide at each indicated location a self-averaging Pitot traverse station with integral flow straightener-equalizer for continuous monitoring of the air volume flow rate in that line.

Each flow traverse station shall contain multiple Pitot total and static pressure sensors placed at concentric area centers. A flow straightener-equalizer consisting of an open cell honeycomb structure having a minimum cell depth to cell size ratio of 12 shall be mounted upstream of the sensors to eliminate all turbulent and rotational flows. The Pitot sensors shall be mounted on averaging manifolds, terminating in external 1/4" FPT fittings for

signal connections. The entire flow station assembly shall be fabricated of Type 316 stainless steel, all welded construction, and be furnished with the required pipe flanges, reducers, weld-in, compression fittings for mounting in the indicated lines.

The flow traverse station shall be capable of measuring the air volume within an accuracy of 2% of actual flow. The station shall be the LO-flo Pitot traverse station as manufactured by Air Monitor Corporation, Santa Rosa, California. Optional wind tunnel calibrations available for higher accuracy.

# LO-flo/SS Pitot Traverse Station

## Dimensional Specifications

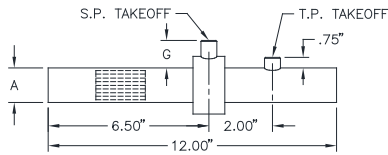

Model P – Plain Ends

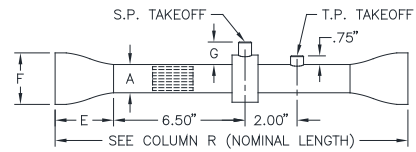

Model R – Reducer

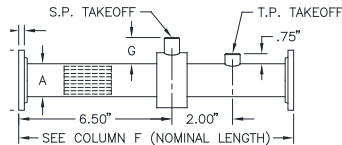

Model F – Flanged Ends

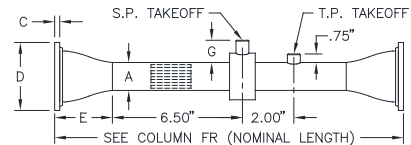

Model FR – Flanged Reducer

Station Nominal Size	Basic Station		Flange Options			Reducer Options		Nominal Length			G Nominal	No. of Sensors		Air Volume Range, CFM	Area Factor Sq Ft	Straightener / Equalizer
	A		Flange Size	ASA 150# Raised Face		Pipe Size	F OD	F	R	FR		Total Pressure	Static Pressure			
	OD	ID		C*	D											
3/4"	1.05	.920	3/4"	.50	3.88	—	—	12.13	—	—	1.10	4	4	2 to 25	.0046	1/8" x 2"
			1"	.56	4.25	1"	1.315	—	16.00	16.12						
			1 1/4"	.62	4.62	1 1/4"	1.66	—	16.00	16.12						
			1 1/2"	.69	5.00	1 1/2"	1.90	—	17.00	17.12						
1"	1.32	1.097	1"	.56	4.25	—	—	12.25	—	—	1.10	4	4	3 to 43	.0077	1/8" x 2"
			1 1/2"	.69	5.00	1 1/2"	1.90	—	17.00	17.25						
			2"	.75	6.00	2"	2.375	—	18.00	18.25						
1 1/4"	1.66	1.442	1 1/4"	.62	4.62	—	—	12.25	—	—	1.10	6	6	5 to 70	.0128	1/8" x 2"
			2"	.75	6.00	2"	2.375	—	18.00	18.25						
			2 1/2"	.88	7.00	2 1/2"	2.975	—	19.00	19.25						
1 1/2"	1.90	1.682	1 1/2"	.69	5.00	—	—	12.25	—	—	1.25	6	6	7 to 95	.0171	1/8" x 2"
			2"	.75	6.00	2"	2.375	—	18.00	18.25						
			2 1/2"	.88	7.00	2 1/2"	2.875	—	19.00	19.25						
			3"	.94	7.50	3"	3.50	—	19.00	19.25						
2"	2.38	2.157	2"	.75	6.00	—	—	12.25	—	—	1.25	8	6	12 to 154	.0275	1/8" x 2"
			3"	.94	7.50	3"	3.50	—	19.00	19.25						
			3 1/2"	.94	8.50	3 1/2"	4.00	—	20.00	20.25						
			4"	.94	9.00	4"	4.50	—	20.00	20.25						
3"	3.50	3.260	3"	.94	7.50	—	—	12.25	—	—	1.25	14	8	24 to 340	.0606	1/8" x 2"
			4"	.94	9.00	4"	4.50	—	20.00	19.25						
			5"	.94	10.00	5"	5.562	—	22.00	20.25						
			6"	1.00	11.00	6"	6.625	—	23.00	20.25						
4"	4.50	4.260	4"	.94	9.00	—	—	12.25	—	—	1.25	14	8	40 to 570	.1025	1/4" x 3"
			6"	1.00	11.00	6"	6.625	—	23.00	23.25						
			8"	1.12	13.50	8"	8.625	—	24.00	24.25						
			5"	.94	10.00	—	—	12.30	—	—						
5"	5.56	5.295	6"	1.00	11.00	6"	6.625	—	23.00	23.30	1.25	14	8	60 to 880	.1558	1/4" x 3"
			8"	1.12	13.50	8"	8.625	—	24.00	24.30						
			6"	1.00	11.00	—	—	12.30	—	—						
6"	6.63	6.357	8"	1.12	13.50	8"	8.625	—	24.00	24.30	1.25	14	8	90 to 1250	.2239	1/4" x 3"
			8"	1.12	13.50	—	—	12.30	—	—						
8"	8.63	8.329	8"	1.12	13.50	—	8.625	12.30	—	—	1.25	14	8	150 to 2160	.3855	1/4" x 3"

